

THREE-INPUT INTELLIGENT ANALYZER



ESSENTIAL INSTRUCTIONS

READ THIS PAGE BEFORE PROCEEDING!

Your instrument purchase from Rosemount Analytical, Inc. is one of the finest available for your particular application. These instruments have been designed, and tested to meet many national and international standards. Experience indicates that its performance is directly related to the quality of the installation and knowledge of the user in operating and maintaining the instrument. To ensure their continued operation to the design specifications, personnel should read this manual thoroughly before proceeding with installation, commissioning, operation, and maintenance of this instrument. If this equipment is used in a manner not specified by the manufacturer, the protection provided by it against hazards may be impaired.

- Failure to follow the proper instructions may cause any one of the following situations to occur: Loss of life; personal injury; property damage; damage to this instrument; and warranty invalidation.
- Ensure that you have received the correct model and options from your purchase order. Verify that this manual covers your model and options. If not, call 1-800-854-8257 or 949-757-8500 to request correct manual.
- For clarification of instructions, contact your Rosemount representative.
- Follow all warnings, cautions, and instructions marked on and supplied with the product.
- Use only qualified personnel to install, operate, update, program and maintain the product.
- Educate your personnel in the proper installation, operation, and maintenance of the product.
- Install equipment as specified in the Installation section of this manual. Follow appropriate local and national codes. Only connect the product to electrical and pressure sources specified in this manual.
- Use only factory documented components for repair. Tampering or unauthorized substitution of parts and procedures can affect the performance and cause unsafe operation of your process.
- All equipment doors must be closed and protective covers must be in place unless qualified personnel are performing maintenance.



WARNING **RISK OF ELECTRICAL SHOCK**

- Equipment protected throughout by double insulation.
- Installation and servicing of this product may expose personnel to dangerous voltages.
- Main power wired to separate power source must be disconnected before servicing.
- Do not operate or energize instrument with case open!
- Signal wiring connected in this box must be rated at least 240 V.
- Non-metallic cable strain reliefs do not provide grounding between conduit connections! Use grounding type bushings and jumper wires.
- Unused cable conduit entries must be securely sealed by non-flammable closures to provide enclosure integrity in compliance with personal safety and environmental protection requirements. Unused conduit openings must be sealed with NEMA 4X or IP65 conduit plugs to maintain the ingress protection rating (NEMA 4X).
- Electrical installation must be in accordance with the National Electrical Code (ANSI/NFPA-70) and/or any other applicable national or local codes.
- Operate only with front panel fastened and in place.
- Proper use and configuration is the responsibility of the user.

CAUTION

This product generates, uses, and can radiate radio frequency energy and thus can cause radio communication interference. Improper installation, or operation, may increase such interference. As temporarily permitted by regulation, this unit has not been tested for compliance within the limits of Class A computing devices, pursuant to Subpart J of Part 15, of FCC Rules, which are designed to provide reasonable protection against such interference. Operation of this equipment in a residential area may cause interference, in which case the user at his own expense, will be required to take whatever measures may be required to correct the interference.

CAUTION

This product is not intended for use in the light industrial, residential or commercial environments per the instrument's certification to EN50081-2.

Emerson Process Management

Liquid Division

2400 Barranca Parkway
Irvine, CA 92606 USA
Tel: (949) 757-8500
Fax: (949) 474-7250

<http://www.raihome.com>

QUICK START GUIDE

Model 1057 Three Input Analyzer

1. Refer to Section 2.0 for mechanical installation instructions.
2. Wire sensor(s) to the signal boards. See Section 3.0 for wiring instructions. Refer to the sensor instruction sheet for additional details. Make current output, alarm relay and power connections.
3. Once connections are secured and verified, apply power to the analyzer.

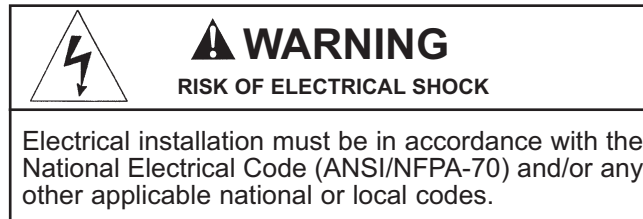

4. When the analyzer is powered up for the first time, **Quick Start** screens appear. Quick Start operating tips are as follows:
 - a. A **backlit** field shows the position of the cursor.
 - b. To move the cursor left or right, use the keys to the left or right of the ENTER key. To scroll up or down or to increase or decrease the value of a digit use the keys above and below the ENTER key. Use the left or right keys to move the decimal point.
 - c. Press ENTER to store a setting. Press EXIT to leave without storing changes. Pressing EXIT during Quick Start returns the display to the initial start-up screen (select language).
5. Complete the steps as shown in the Quick Start Guide flow diagram, Fig. A on the following page.
6. After the last step, the main display appears. The outputs are assigned to default values.
7. To change output, and temperature-related settings, go to the main menu and choose **Program**. Follow the prompts. For a general guide to the Program menu, see the Quick Reference Guide, Fig.B.
8. To return the analyzer to the default settings, choose **Reset Analyzer** under the Program menu.

QUICK START GUIDE – MODEL 1057

Figure A. QUICK START GUIDE

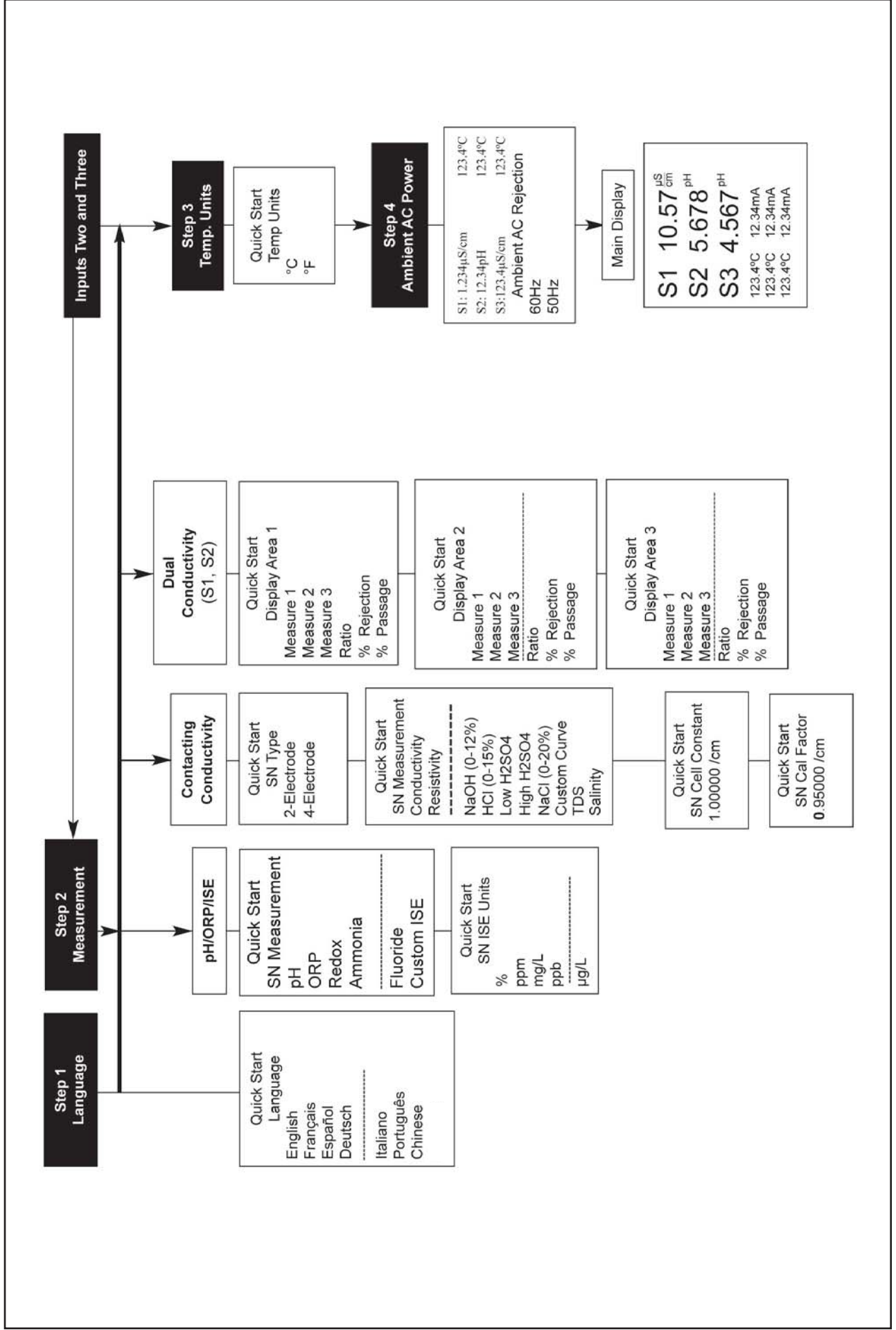

QUICK REFERENCE GUIDE

Figure B. MODEL 1057 MENU TREE

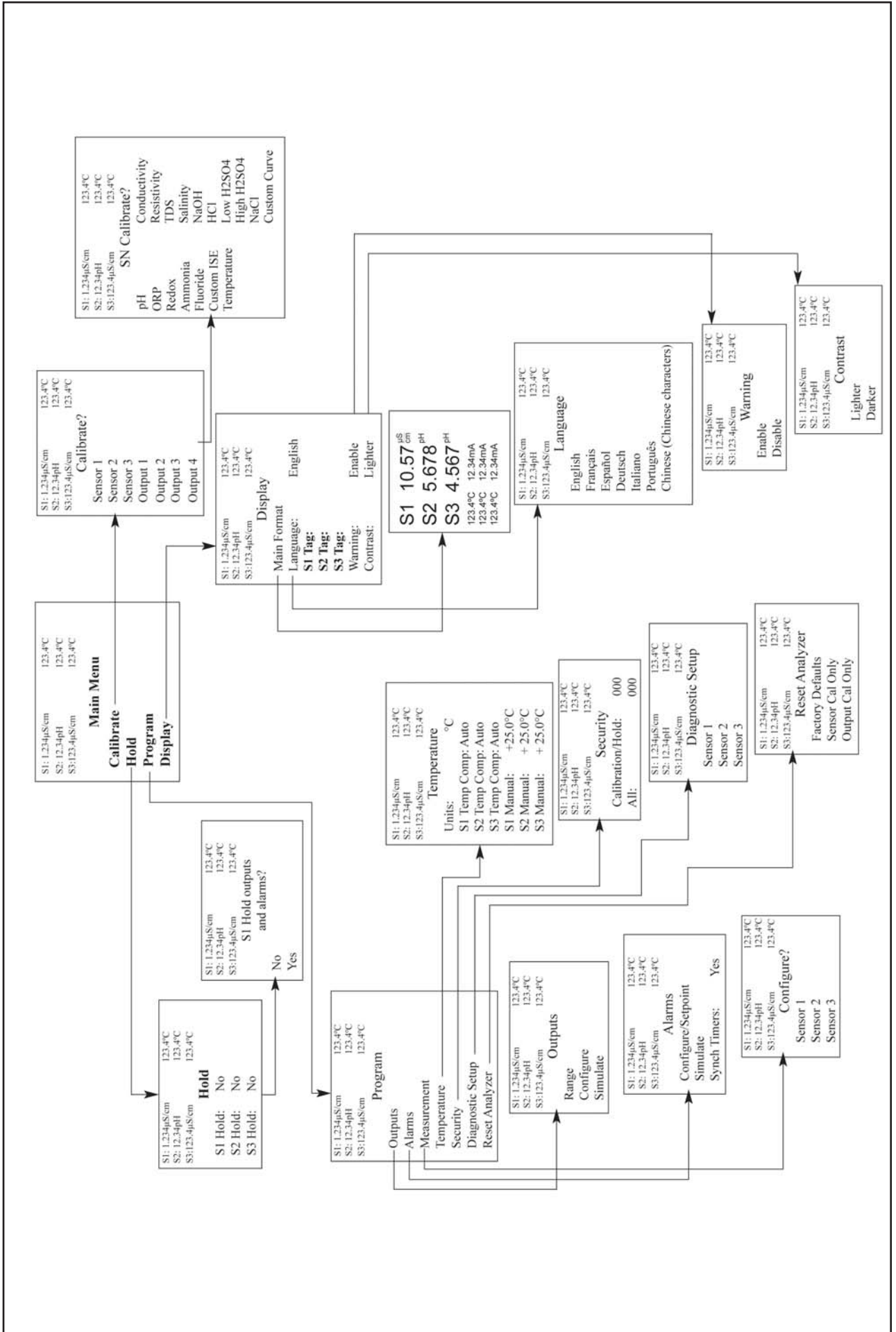

About This Document

This manual contains instructions for installation and operation of the Model 1057 Three-Input Intelligent Analyzer. The following list provides notes concerning all revisions of this document.

<u>Rev. Level</u>	<u>Date</u>	<u>Notes</u>
A	01/09	This is the initial release of the product manual. The manual has been reformatted to reflect the Emerson documentation style and updated to reflect any changes in the product offering.

MODEL 1057 THREE INPUT INTELLIGENT ANALYZER

TABLE OF CONTENTS

Section	Title	Page
	QUICK START GUIDE	
	QUICK REFERENCE GUIDE	
	TABLE OF CONTENTS	
1.0	DESCRIPTION AND SPECIFICATIONS	1
2.0	INSTALLATION	5
2.1	Unpacking and Inspection.....	5
2.2	Installation.....	5
3.0	WIRING	9
3.1	General	9
3.2	Preparing Conduit Openings.....	10
3.3	Preparing Sensor Cable	10
3.4	Power, Output, Alarms and Sensor Connections.....	10
4.0	DISPLAY AND OPERATION	15
4.1	User Interface	15
4.2	Instrument Keypad.....	15
4.3	Main Display	16
4.4	Menu System.....	17
5.0	PROGRAMMING THE ANALYZER – BASICS	19
5.1	General	19
5.2	Changing StartUp Settings	19
5.3	Choosing Temperature Units and Automatic/Manual Temperature Compensation .	20
5.4	Configuring and Ranging the Current Outputs.....	20
5.5	Setting a Security Code	22
5.6	Security Access.....	23
5.7	Using Hold	23
5.8	Resetting Factory Default Settings	24
5.9	Programming Alarm Relays	25
6.0	PROGRAMMING - MEASUREMENTS	29
6.1	Programming Measurements – Introduction	29
6.2	pH	30
6.3	ORP	31
6.4	Contacting Conductivity	33
7.0	CALIBRATION	39
7.1	Calibration – Introduction	39
7.2	pH Calibration	39
7.3	ORP Calibration	42
7.4	Contacting Conductivity Calibration	43
7.5	Calibrating Temperature	46
8.0	RETURN OF MATERIAL	51
	Warranty.....	51
	Ordering Information.....	53

TABLE OF CONTENTS CONT'D

LIST OF FIGURES

Fig#	Section	Figure Title	Page
A	PREFACE	Quick Start Guide	
B	PREFACE	Quick Reference Guide	
2-1	SEC 2.0	Panel Mounting Dimensions	6
2-2	SEC 2.0	Pipe and Wall Mounting Dimensions	7
3-1	SEC 3.1	Connectors and Signal Input boards	9
3-2	SEC 3.4	24VDC Power Supply	10
3-3	SEC 3.4	Switching AC Power Supply.....	10
3-4	SEC 3.4	Alarm Relay Wiring	11
3-5	SEC 3.4	Contacting Conductivity board and sensor cable leads	12
3-6	SEC 3.4	pH/ORP/ISE signal board and sensor cable leads	12
3-7	SEC 3.4	Power Wiring for Model 1057 85-265 VAC	13
3-8	SEC 3.4	Output Wiring for Model 1057 Main PCB.....	13
3-9	SEC 3.4	Power Wiring for Model 1057 24VDC	14
4-1	SEC 4.3	Formatting the Main Display	18
5-1	SEC 5.3.2	Choosing Temp Units and Manual Auto Temp Compensation	20
5-2	SEC 5.4.5	Configuring and Ranging the Current Outputs.....	21
5-3	SEC 5.5.2	Setting A Security Code	22
5-4	SEC 5.7.2	Using Hold	23
5-5	SEC 5.8.2	Resetting Factory Default Settings	24
6-1	SEC 6.4	Configuring pH/ORP Measurements	36
6-2	SEC 6.4	Configure Contacting Measurements	37
7-1	SEC 7.2	Calibrate pH	47
7-2	SEC 7.3	Calibrate ORP.....	48
7-3	SEC 7.4	Calibrate Contacting Conductivity.....	49
7-4	SEC 7.9	Calibrate Temperature	50

LIST OF TABLES

Number	Section	Table Title	Page
5-1	SEC 5.2.1	Measurements and Measurement Units	19
6-1	SEC 6.2.1	pH Measurement Programming	30
6-2	SEC 6.3.1	ORP Measurement Programming.....	31
6-3	SEC 6.4.1	Contacting Conductivity Measurement Programming.....	33
7-1	SEC 7.2	pH Calibration Routines	39
7-2	SEC 7.3	ORP Calibration Routine.....	42
7-3	SEC 7.4	Contacting Conductivity Calibration Routines.....	43
7-11	SEC 7.5	Temperature Calibration Routines.....	46

SECTION 1.0. DESCRIPTION AND SPECIFICATIONS

- MULTI-PARAMETER INSTRUMENT – up to three inputs. Choose pH/ORP/ISE or Contacting Conductivity/Resistivity in any combination.
- LARGE DISPLAY – large easy-to-read process measurements.
- EASY TO INSTALL – modular boards, removable connectors, easy to wire power, sensors, and outputs.
- INTUITIVE MENU SCREENS with advanced diagnostics and help screens.
- SEVEN LANGUAGES included: English, French, German, Italian, Spanish, Portuguese, and Chinese.
- FOUR ANALOG OUTPUTS

FEATURES AND APPLICATIONS

The Model 1057 analyzer offers three sensor inputs and four current outputs thus reducing the cost per loop and saving panel space. The pH signal input board supports pH, ORP, and Ion-Selective Electrode measurements. The Conductivity signal input board supports contacting conductivity, resistivity, Total Dissolved Solids, salinity and percent concentration curves for special applications. The modular design allows signal input boards to be field replaced making configuration changes easy. Conveniently, live process values are always displayed during programming and calibration routines. Standard features include isolated inputs, 7 embedded local languages, four 4-20mA current outputs, 4 alarm relays and removable connectors for power and current outputs.

QUICK START PROGRAMMING: Exclusive Quick Start screens appear the first time the Model 1057 is powered. The instrument auto-recognizes each measurement board and prompts the user to configure each sensor loop in a few quick steps for immediate deployment.

MENUS: Menu screens for calibrating and programming are simple and intuitive. Plain language prompts and help screens guide the user through these procedures.

4-ELECTRODE CONDUCTIVITY: For applications requiring wide range conductivity measurements, use Rosemount Analytical's Model 410VP **PUR-SENSE™** 4-electrode sensor. It is not affected by fouling and is supported by the same contacting conductivity signal board as traditional 2-electrode sensors.

SENSOR INPUT AND OUTPUT: The Model 1057 accepts one, two or three inputs. Four 0/4-20 mA current outputs can be programmed to correspond to measurement or temperature.

ENCLOSURE: The instrument fits standard ½ DIN panel cutouts. The versatile enclosure design supports panel-mount, pipe-mount, and surface/wall-mount installations.

ISOLATED INPUTS: Inputs are isolated from other signal sources and earth ground. This ensures clean signal inputs for single and dual input configurations. For multi-input configurations, isolation allows any combination of measurements and signal inputs without cross-talk or signal interference.

TEMPERATURE: Most measurements require temperature compensation. The Model 1057 will automatically recognize Pt100 or Pt1000 RTDs built into the sensor.

SECURITY ACCESS CODES: Two levels of security access are available. Program one access code for routine calibration and hold of current outputs; program another access code for all menus and functions.

DIAGNOSTICS: The analyzer continuously monitors itself and the sensor(s) for problematic conditions. The display flashes Fault and/or Warning when these conditions occur.

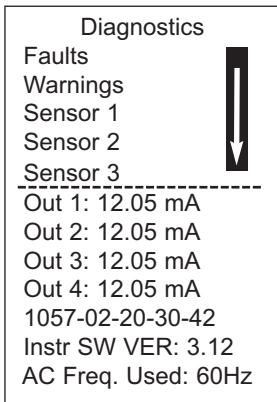

Information about each condition is quickly accessible by pressing DIAG on the keypad. User help screens are displayed for most fault and warning conditions to assist in troubleshooting.

DISPLAY: The high-contrast LCD provides live measurement readouts in large digits and shows up to four additional process variables or diagnostic parameters. The display is back-lit and the format can be customized to meet user requirements.

LOCAL LANGUAGES :

Rosemount Analytical extends its worldwide reach by offering seven local languages – English, French, German, Italian, Spanish, Portuguese, and Chinese. Every unit includes user programming menus; calibration routines; faults and warnings; and user help screens in all seven languages. The displayed language can be easily set and changed using the menus.

CURRENT OUTPUTS: Four 4-20 mA or 0-20 mA current outputs are electrically isolated. Outputs are fully scalable and can be programmed to linear or logarithmic modes. Output dampening can be enabled with time constants from 0 to 999 seconds.

SPECIFICATIONS - General

- Enclosure:** Polycarbonate. NEMA 4X/CSA 4 (IP65).
- Dimensions:** Overall 155 x 155 x 131mm (6.10 x 6.10 x 5.15 in.). Cutout: 1/2 DIN 139mm x 139mm (5.45 x 5.45 in.) Minimum depth for panel mount installations 101.6 mm (4.0 in).
- Conduit Openings:** Accepts 1/2" or PG13.5 conduit fittings
- Display:** Monochromatic graphic liquid crystal display. 128 x 96 pixel display resolution. Backlit. Active display area: 58 x 78mm (2.3 x 3.0 in.).
- Ambient Temperature and Humidity:** 0 to 55°C (32 to 131°F). RH 5 to 95% (non-condensing)
- Storage Temperature Effect:** -20 to 60°C (-4 to 140°F)

Power: Code -02: 20 to 30 VDC. 15 W.
Code -03: 84 to 265 VAC, 47.5 to 65.0 Hz, switching. 15 W.
Note: Code -02 and -03 power supplies include four programmable relays

Equipment protected by double insulation

RFI/EMI: EN-61326
LVD: EN-61010-1

POLLUTION DEGREE 2: Normally only non-conductive pollution occurs. Occasionally, however, a temporary conductivity caused by condensation must be expected. Altitude: for use up to 2000 meters (6562 ft.)

Alarms relays: Four alarm relays for process measurement(s) or temperature. Any relay can be configured as a fault alarm instead of a process alarm. Each relay can be configured independently and each can be programmed with interval timer settings.

Relays: Form C, SPDT, epoxy sealed

	Maximum Relay Current	
	Resistive	
	28 VDC	5.0 A
	115 VAC	5.0 A
	230 VAC	5.0 A

Inductive load: 1/8 HP motor (max.), 40 VAC

	CAUTION
RISK OF ELECTRICAL SHOCK	

- Inputs:** Up to three sensor inputs-electrically isolated
- Outputs:** Four 4-20 mA or 0-20 mA isolated current outputs. Fully scalable. Max Load: 550 Ohms.
- Current Output Accuracy:** ±0.05 mA @25 °C
- Terminal Connections Rating:** Power connector (3-leads): 24-12 AWG wire size. Signal board terminal blocks: 26-16 AWG wire size. Current output connectors (4-leads): 24-16 AWG wire size. Alarm relay terminal blocks: 24-12 AWG wire size
- Weight/Shipping Weight:** (rounded up to nearest lb or nearest 0.5 kg): 3 lbs/4 lbs (1.5 kg/2.0 kg)

CONTACTING CONDUCTIVITY (Codes -20, -30 and -40)

Measures conductivity in the range 0 to 600,000 $\mu\text{S/cm}$ (600mS/cm). Measurement choices are conductivity, resistivity, total dissolved solids, salinity, and % concentration. The % concentration selection includes the choice of five common solutions (0-12% NaOH, 0-15% HCl, 0-20% NaCl, and 0-25% or 96-99.7% H_2SO_4).

The conductivity concentration algorithms for these solutions are fully temperature compensated. Three temperature compensation options are available: manual slope (X%/°C), high purity water (dilute sodium chloride), and cation conductivity (dilute hydrochloric acid). Temperature compensation can be disabled, allowing the analyzer to display raw conductivity. For more information concerning the use and operation of the contacting conductivity sensors, refer to the product data sheets.

Note: When contacting conductivity sensors are used for sensor 1 and sensor 2, Model 1057 can derive an inferred pH value called pHCalc. pHCalc is calculated pH, not directly measured pH.

Note: Selected 4-electrode, high-range contacting conductivity sensors are compatible with Model 1056.

Input filter: time constant 1 - 999 sec, default 2 sec.

Response time: 3 seconds to 100% of final reading

Salinity: uses Practical Salinity Scale

Total Dissolved Solids: Calculated by multiplying conductivity at 25°C by 0.65

Temperature Specifications:

Temperature range	0-150°C
Temperature Accuracy, Pt-1000, 0-50 °C	$\pm 0.1^\circ\text{C}$
Temperature Accuracy, Pt-1000, Temp. > 50 °C	$\pm 0.5^\circ\text{C}$

RECOMMENDED SENSORS FOR CONDUCTIVITY:

All Rosemount Analytical ENDURANCE Model 400 series conductivity sensors (Pt 1000 RTD) and **PUR-SENSE** Model 410 sensor.

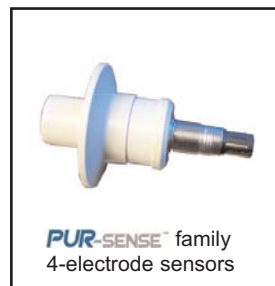

PERFORMANCE SPECIFICATIONS

Recommended Range – Contacting Conductivity

Cell Constant	0.01 $\mu\text{S/cm}$	0.1 $\mu\text{S/cm}$	1.0 $\mu\text{S/cm}$	10 $\mu\text{S/cm}$	100 $\mu\text{S/cm}$	1000 $\mu\text{S/cm}$	10mS/cm	100mS/cm	1000mS/cm
0.01	0.01 $\mu\text{S/cm}$ to 200 $\mu\text{S/cm}$					200 $\mu\text{S/cm}$ to 6000 $\mu\text{S/cm}$			
0.1	0.1 $\mu\text{S/cm}$ to 2000 $\mu\text{S/cm}$					2000 $\mu\text{S/cm}$ to 60mS/cm			
1.0	1 $\mu\text{S/cm}$ to 20mS/cm					20mS/cm to 600mS/cm			
4-electrode	2 $\mu\text{S/cm}$ to 300mS/cm								

Cell Constant Linearity

	$\pm 0.6\%$ of reading in recommended range
	+2 to -10% of reading outside high recommended range
	$\pm 5\%$ of reading outside low recommended range
	$\pm 4\%$ of reading in recommended range

pH/ORP/ISE (Codes -22, -32 and -42)

For use with any standard pH or ORP sensor. Measurement choices are pH, ORP, Redox, ammonia, fluoride or custom ISE. The automatic buffer recognition feature uses stored buffer values and their temperature curves for the most common buffer standards available worldwide. The analyzer will recognize the value of the buffer being measured and perform a self stabilization check on the sensor before completing the calibration. Manual or automatic temperature compensation is menu selectable. Change in pH due to process temperature can be compensated using a programmable temperature coefficient. For more information concerning the use and operation of the pH or ORP sensors, refer to the product data sheets.

Model 1057 can also derive an inferred pH value called pHCalc (calculated pH). pHCalc can be derived and displayed when two contacting conductivity sensors are used as sensor 1 and sensor 2.

PERFORMANCE SPECIFICATIONS - ANALYZER (pH INPUT)

Measurement Range [pH]: 0 to 14 pH

Accuracy: ±0.01 pH

Diagnostics: Glass impedance, reference impedance

Temperature coefficient: ±0.002pH/ °C

Solution temperature correction: Pure water, dilute base and custom.

Buffer recognition: NIST, DIN 19266, JIS 8802, and BSI.

Input filter: Time constant 1 - 999 seconds, default 4 seconds.

Response time: 5 seconds to 100%

RECOMMENDED SENSORS FOR pH:

All standard pH sensors.

Temperature Specifications:

Temperature range	0-150°C
Temperature Accuracy, Pt-100, 0-50 °C	± 0.5°C
Temperature Accuracy, Temp. > 50 °C	± 1°C

PERFORMANCE SPECIFICATIONS - ANALYZER (ORP INPUT)

Measurement Range [ORP]: -1500 to +1500 mV

Accuracy: ± 1 mV

Temperature coefficient: ±0.12mV / °C

Input filter: Time constant 1 - 999 seconds, default 4 seconds.

Response time: 5 seconds to 100% of final reading

RECOMMENDED SENSORS FOR ORP:

All standard ORP sensors.



SECTION 2.0. INSTALLATION

2.1 UNPACKING AND INSPECTION 2.2 INSTALLATION

2.1 UNPACKING AND INSPECTION

Inspect the shipping container. If it is damaged, contact the shipper immediately for instructions. Save the box. If there is no apparent damage, unpack the container. Be sure all items shown on the packing list are present. If items are missing, notify Rosemount Analytical immediately.

2.2 INSTALLATION

2.2.1 General Information

1. Although the analyzer is suitable for outdoor use, do not install it in direct sunlight or in areas of extreme temperatures.
2. Install the analyzer in an area where vibration and electromagnetic and radio frequency interference are minimized or absent.
3. Keep the analyzer and sensor wiring at least one foot from high voltage conductors. Be sure there is easy access to the analyzer.
4. The analyzer is suitable for panel, pipe, or surface mounting. Refer to the table below.

Type of Mounting	Figure
Panel	2-1
Wall and Pipe	2-2



WARNING

RISK OF ELECTRICAL SHOCK

Electrical installation must be in accordance with the National Electrical Code (ANSI/NFPA-70) and/or any other applicable national or local codes.

FIGURE 2-1 PANEL MOUNTING DIMENSIONS

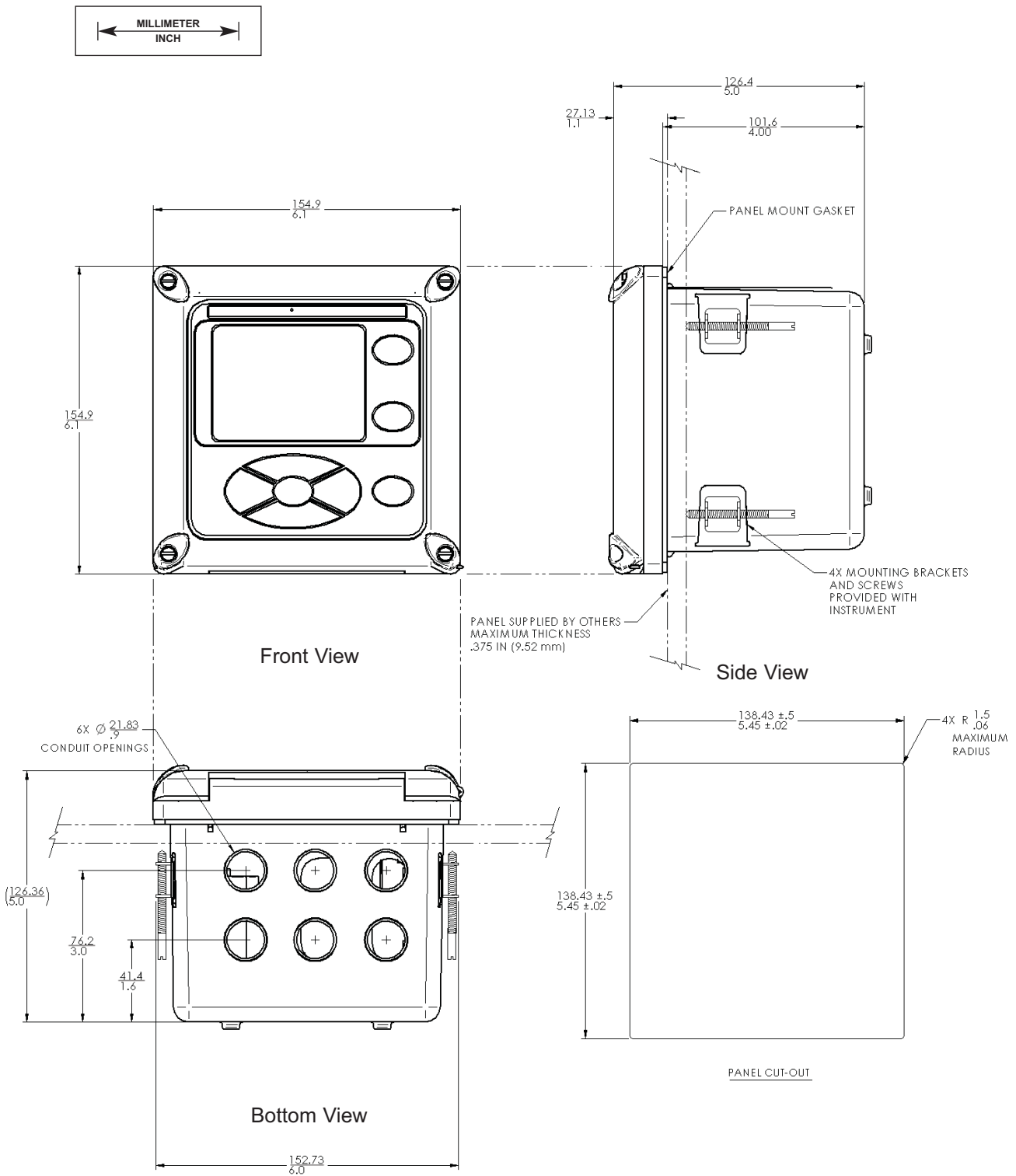

The front panel is hinged at the bottom. The panel swings down for easy access to the wiring locations. Panel mounting seal integrity (4/4X) for outdoor applications is the responsibility of the end user.

FIGURE 2-2 PIPE AND WALL MOUNTING DIMENSIONS

(Mounting bracket PN:23820-00)

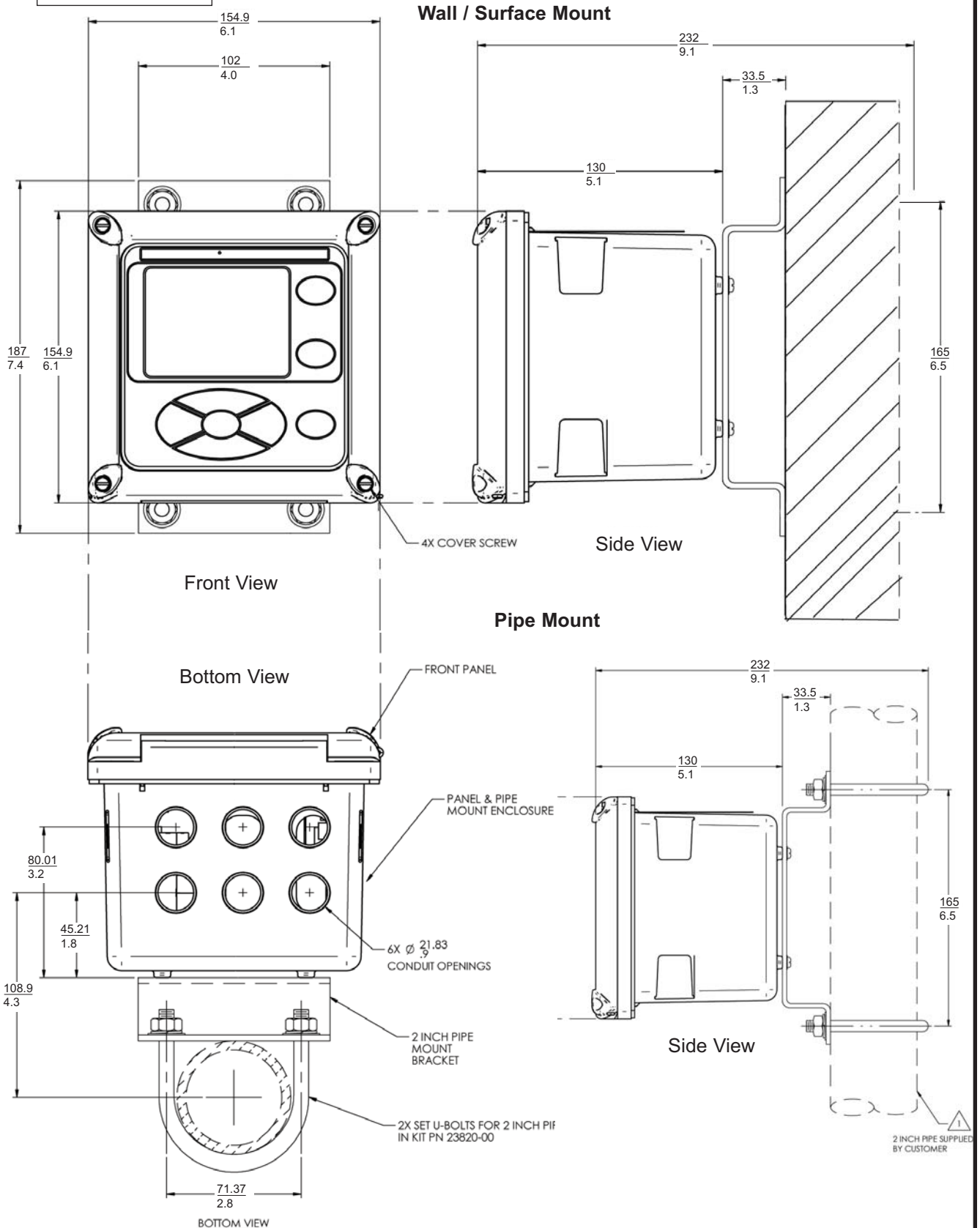

The front panel is hinged at the bottom. The panel swings down for easy access to the wiring locations.

SECTION 3.0. WIRING

3.1 GENERAL

3.2 PREPARING CONDUIT OPENINGS

3.3 PREPARING SENSOR CABLE

3.4 POWER, OUTPUT, AND SENSOR CONNECTIONS

3.1 GENERAL

The Model 1057 is easy to wire. It includes removable connectors and slide-out signal input boards.

3.1.1 Removable connectors and signal input boards

Model 1057 uses removable signal input boards and communication boards for ease of wiring and installation. Each of the signal input boards can be partially or completely removed from the enclosure for wiring. The Model 1057 has three slots for placement of up to three signal input boards and one communication board.

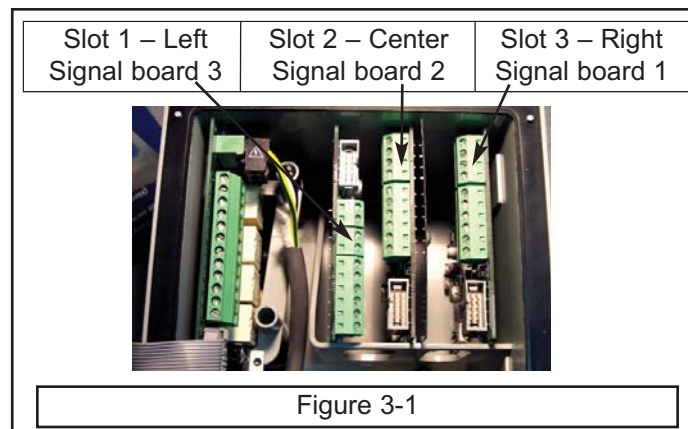

Note: If the -UL option code has been ordered, a plastic insulator shield surrounds the entire power supply board (AC power supply only). The protective insulator shield does not appear in this photo.

3.1.2 Signal input boards

Slots 1, 2 and 3 are for signal input measurement boards. Wire the sensor leads to the measurement board following the lead locations marked on the board. After wiring the sensor leads to the signal board, carefully slide the wired board fully into the enclosure slot and take up the excess sensor cable through the cable gland. Tighten the cable gland nut to secure the cable and ensure a sealed enclosure.

Note: that signal input board 3 is inserted into slot 1. Board 3 is inverted in the slot to allow board components to face to the right. Board 3 uses a long ribbon cable to connect to the main PCB. Boards 1 and 2 use a split ribbon cable to connect both signal boards to a common connector on the main board.

3.1.3 Alarm relays

Four alarm relays are supplied with the switching power supply (84 to 265VAC, -03 order code) and the 24VDC power supply (20-30VDC, -02 order code). All relays can be used for process measurement(s) or temperature. Any relay can be configured as a fault alarm instead of a process alarm. Each relay can be configured independently and each can be programmed as an interval timer, typically used to activate pumps or control valves. As process alarms, alarm logic (high or low activation or USP*) and deadband are user-programmable. Customer-defined failsafe operation is supported as a programmable menu function to allow all relays to be energized or not-energized as a default condition upon powering the analyzer.

The USP alarm can be programmed to activate when the conductivity is within a user-selectable percentage of the limit. USP alarming is available only when a contacting conductivity measurement board is installed.

3.2 PREPARING CONDUIT OPENINGS

There are six conduit openings in all configurations of Model 1057. (Note that four plugs are provided upon shipment.)

Conduit openings accept 1/2-inch conduit fittings or PG13.5 cable glands. To keep the case watertight, block unused openings with NEMA 4X or IP65 conduit plugs.

NOTE: Use watertight fittings and hubs that comply with your requirements. Connect the conduit hub to the conduit before attaching the fitting to the analyzer.

3.3 PREPARING SENSOR CABLE

The Model 1057 is intended for use with all Rosemount Analytical pH/ORP and contacting conductivity sensors. Refer to the sensor installation instructions for details on preparing sensor cables.

3.4 POWER, OUTPUT, AND SENSOR CONNECTIONS

All field wiring must be rated for 75°C or higher. Each instrument includes a printed label inside the enclosure stating this wiring requirement.

3.4.1 Power wiring

Two Power Supplies are offered for Model 1057:

- a. 24VDC (20 – 30V) Power Supply (-02 ordering code)
- b. 84 – 265 VAC Switching Power Supply (-03 ordering code)

AC mains (115 or 230V) leads and 24VDC leads are wired to the Power Supply board which is mounted vertically on the left side of the main enclosure cavity. Each lead location is clearly marked on the Power Supply board. Wire the power leads to the Power Supply board using the lead markings on the board.

24VDC Power Supply (-02 ordering code) is shown below:

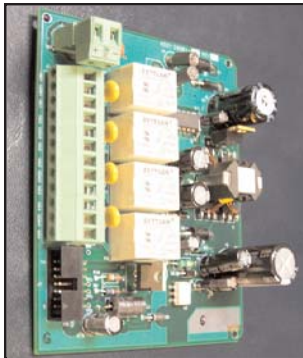

This power supply automatically detects DC power and accepts 20VDC to 30VDC inputs. Four programmable alarm relays are included.

Figure 3-2

Switching AC Power Supply (-03 ordering code) is shown below:

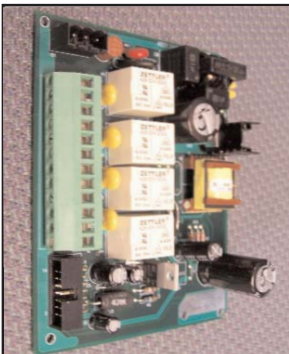

This power supply automatically detects AC line conditions and switches to the proper line voltage and line frequency. Four programmable alarm relays are included.

Figure 3-3

3.4.2 Current Output wiring

All instruments are shipped with four 4-20mA current outputs. Wiring locations for the outputs are on the Main board which is mounted on the hinged door of the instrument. Wire the output leads to the correct position on the Main board connectors using the lead markings (+/positive, -/negative) on the board. Male mating connectors are provided with each unit. Use a 3/32"-wide standard blade screwdriver.

3.4.3 Alarm relay wiring

Four alarm relays are supplied with the switching power supply (84 to 265VAC, -03 order code) and the 24VDC power supply (20-30VDC, -02 order code). Wire the relay leads on each of the independent relays to the correct position on the power supply board using the printed lead markings (NO/Normally Open, NC/Normally Closed, or Com/Common) on the board.

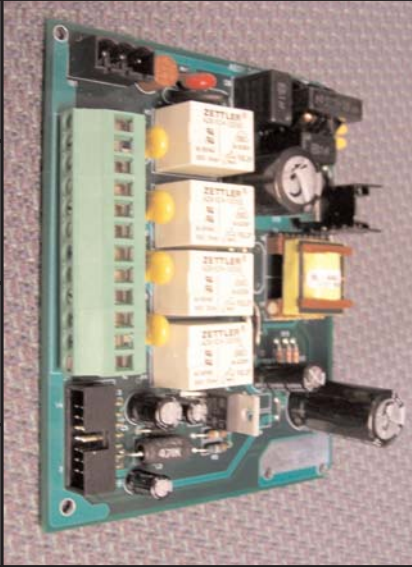
NO1	RELAY 1	
COM1		
NC1		
NO2	RELAY 2	
COM2		
NC2		
NO3	RELAY 3	
COM3		
NC3		
NO4	RELAY 4	
COM4		
NC4		
Figure 3-4 Alarm Relay Wiring for Model 1057 Switching Power Supply (-03 Order Code)		

	<p>WARNING RISK OF ELECTRICAL SHOCK</p>
<p>Electrical installation must be in accordance with the National Electrical Code (ANSI/NFPA-70) and/or any other applicable national or local codes.</p>	

3.4.4 Sensor wiring to signal boards

Wire the correct sensor leads to the measurement board using the lead locations marked directly on the board. After wiring the sensor leads to the signal board, carefully slide the wired board fully into the enclosure slot and take up the excess sensor cable through the cable gland.

For best EMI/RFI protection use shielded output signal cable enclosed in an earth-grounded metal conduit. Connect the shield to earth ground. AC wiring should be 14 gauge or greater. Provide a switch or breaker to disconnect the analyzer from the main power supply. Install the switch or breaker near the analyzer and label it as the disconnecting device for the analyzer.

Keep sensor and output signal wiring separate from power wiring. Do not run sensor and power wiring in the same conduit or close together in a cable tray.

Sec. 3.4 Signal board wiring

Figure 3-5 Contacting Conductivity signal board and Sensor cable leads

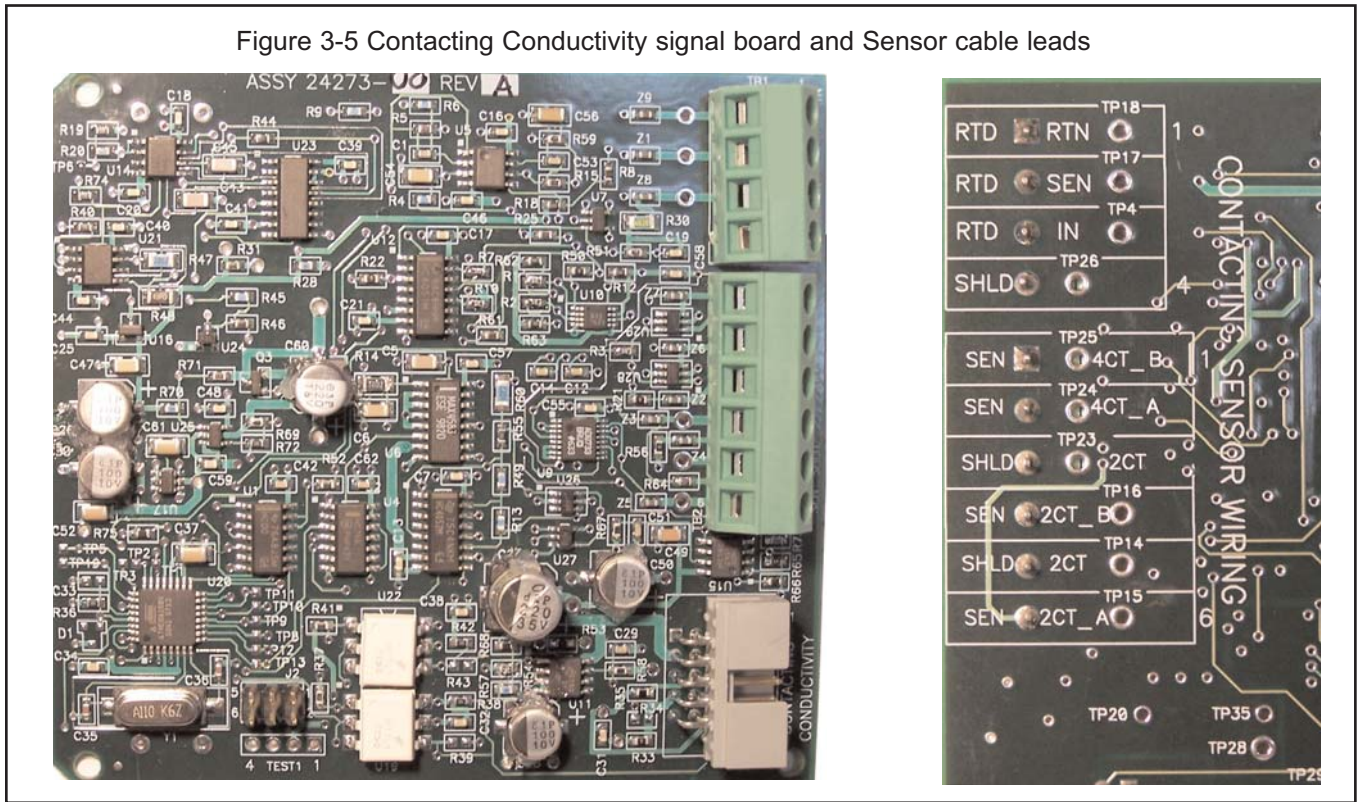
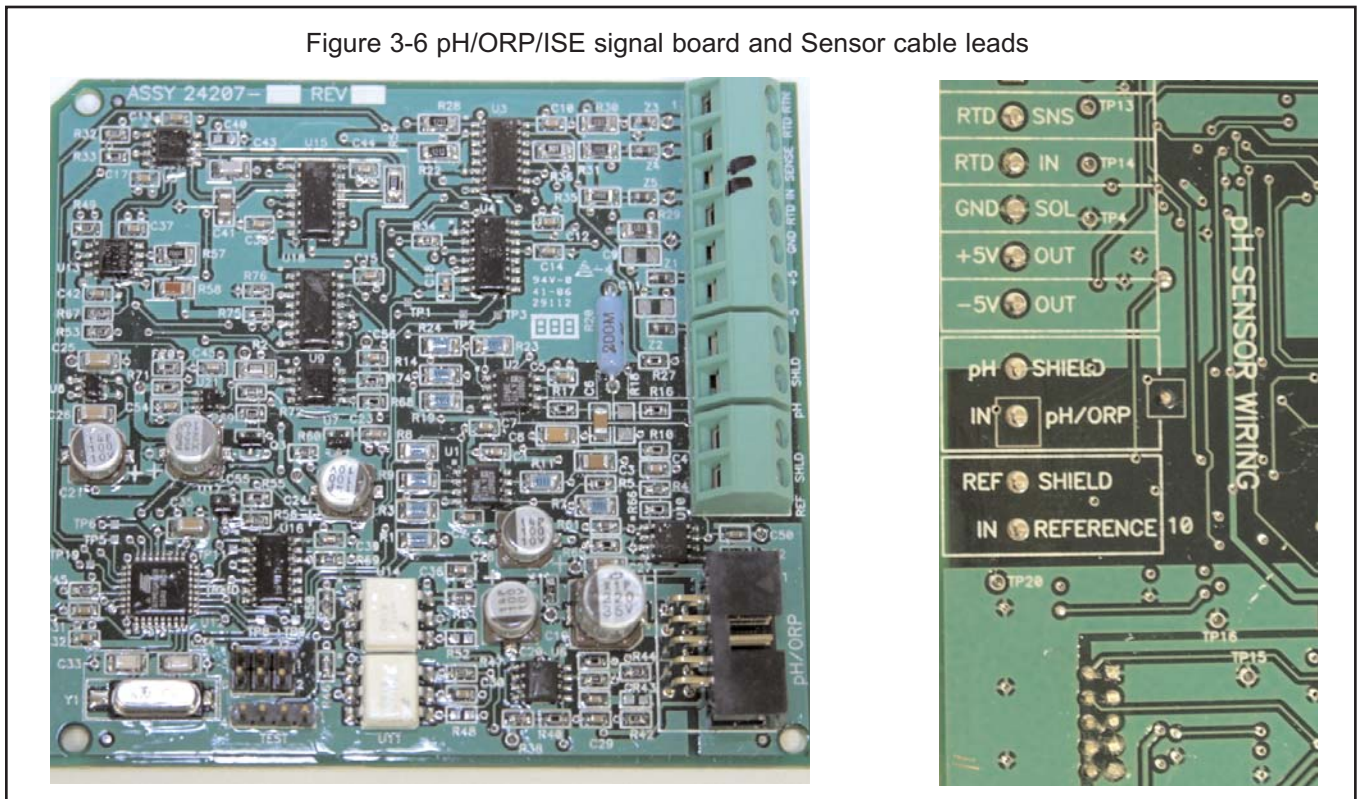
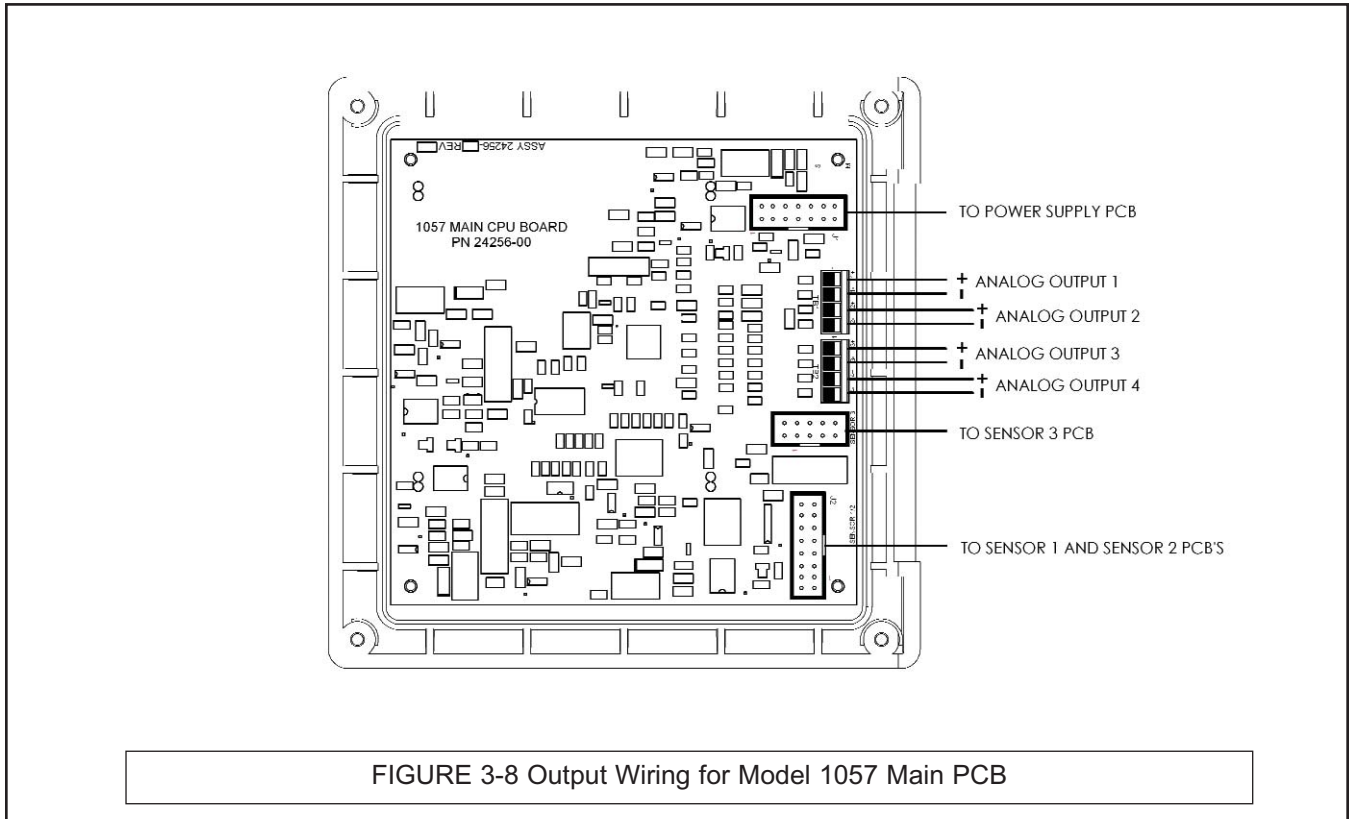
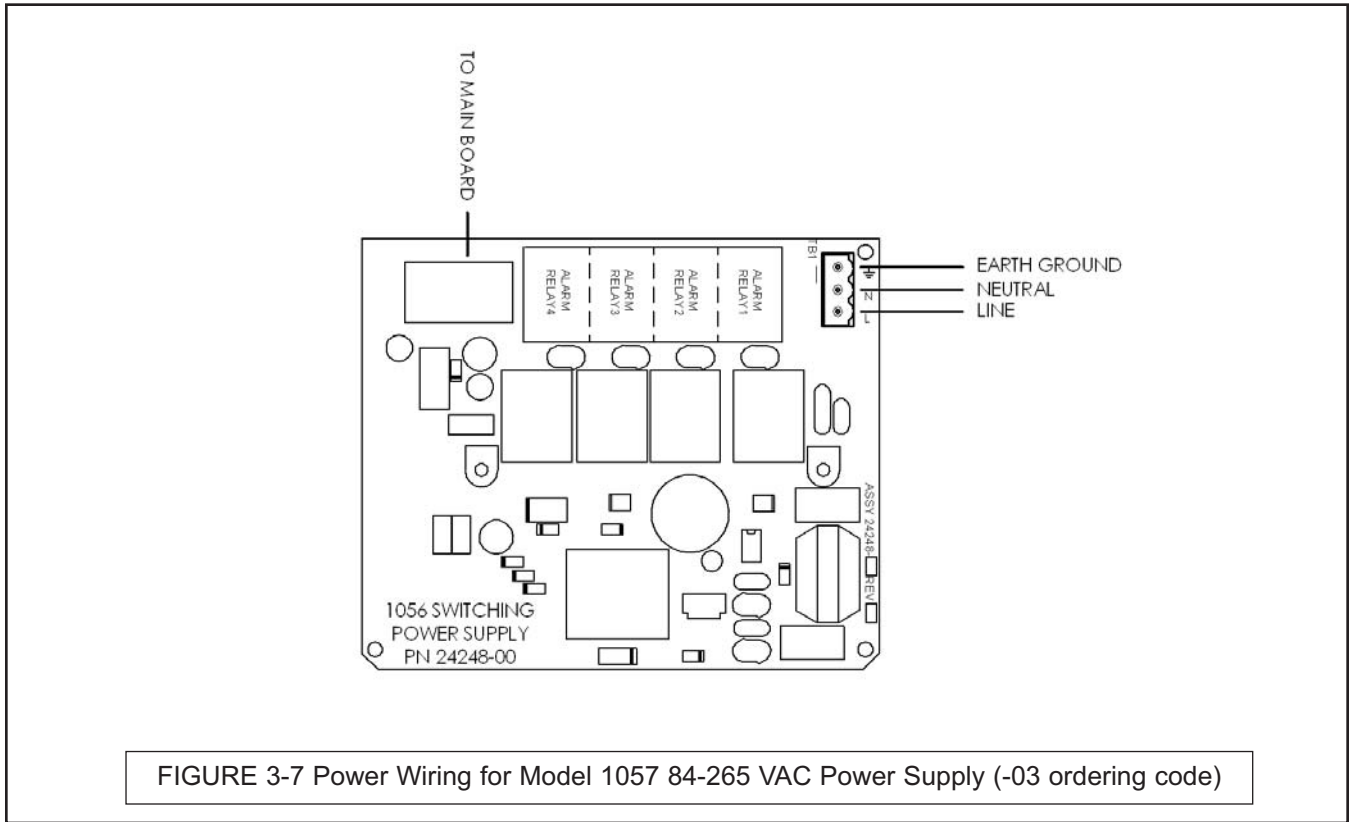

Figure 3-6 pH/ORP/ISE signal board and Sensor cable leads





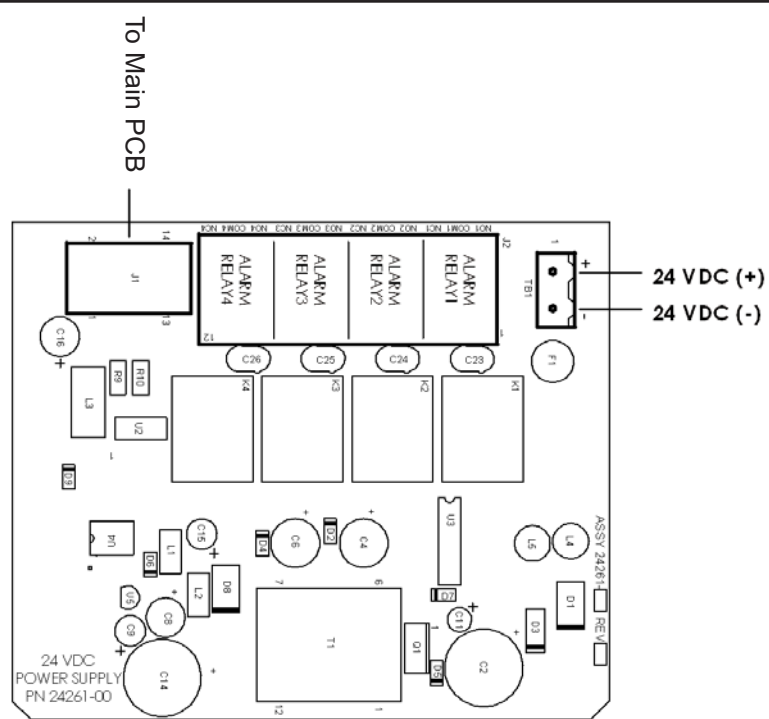

FIGURE 3-9 Power Wiring for Model 1057 24VDC Power Supply (-02 ordering code)

SECTION 4.0 DISPLAY AND OPERATION

4.1 USER INTERFACE

4.2 KEYPAD

4.3 MAIN DISPLAY

4.4 MENU SYSTEM

4.1 USER INTERFACE

The Model 1057 has a large display which shows three live measurement readouts in large digits and up to six additional process variables or diagnostic parameters concurrently. The display is back-lit and the format can be customized to meet user requirements. The intuitive menu system allows access to Calibration, Hold (of current outputs), Programming, and Display functions by pressing the MENU button. In addition, a dedicated DIAGNOSTIC button is available to provide access to useful operational information on installed sensor(s) and any problematic conditions that might occur. The display flashes Fault and/or Warning when these conditions occur. Help screens are displayed for most fault and warning conditions to guide the user in troubleshooting.

During calibration and programming, key presses cause different displays to appear. The displays are self-explanatory and guide the user step-by-step through the procedure.



4.2 INSTRUMENT KEYPAD

There are 4 Function keys and 4 Selection keys on the instrument keypad.

Function keys:

The **MENU key** is used to access menus for programming and calibrating the instrument. Four top-level menu items appear when pressing the MENU key:

- **Calibrate:** calibrate attached sensors and analog outputs.
- **Hold:** Suspend current outputs.
- **Program:** Program outputs, measurement, temperature, security and reset.
- **Display:** Program display format, language, warnings, and contrast

Pressing MENU always causes the main menu screen to appear. Pressing MENU followed by EXIT causes the main display to appear.

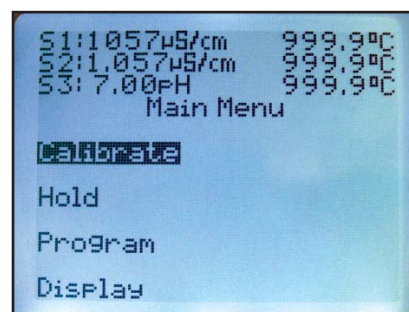

Pressing the **DIAG** key displays active Faults and Warnings, and provides detailed instrument information and sensor diagnostics including: Faults, Warnings, Sensor 1, 2 and 3 information, Current Outputs live values, model configuration string e.g. 1057-03 -20-30-42-AN, Instrument Software version, and AC frequency. Pressing ENTER on Sensor 1 or Sensor 2 provides useful diagnostics and information (as applicable): Measurement, Sensor Type, Raw signal value, Cell constant, Zero Offset and Temperature. Offset, selected

measurement range, Cable Resistance, Temperature Sensor Resistance, Signal Board software version.

The ENTER key. Pressing ENTER stores numbers and settings and moves the display to the next screen.

The EXIT key. Pressing EXIT returns to the previous screen without storing changes.

Selection keys:

Surrounding the ENTER key, four Selection keys – up, down, right and left, move the cursor to all areas of the screen while using the menus.

Selection keys are used to:

1. select items on the menu screens
2. scroll up and down the menu lists.
3. enter or edit numeric values.
4. move the cursor to the right or left
5. select measurement units during operations

4.3 MAIN DISPLAY

The Model 1057 displays one, two or three primary measurement values, up to six secondary measurement values, a fault and warning banner, alarm relay flags.



Process measurements:

Three process variables are displayed if three signal boards are installed. One process variable and process temperature is displayed if one signal board is installed with one sensor. The Upper display area shows the Sensor 1 process reading. The Center display area shows the Sensor 2 process reading. For dual conductivity, the display areas can be assigned to different process variables as follows:

Process variables for display- examples:
Measure 1
Measure 2
Measure 3
% Reject
% Pass
Ratio
Blank
pH Calc

Secondary values:

Up to six secondary values are shown in six display quadrants at the bottom of the screen. All four secondary value positions can be programmed by the user to any display parameter available. Possible secondary values include:

Displayable Secondary Values	
Slope 1, 2, 3	Output 1 mA
Ref Off 1, 2, 3	Output 2 mA
GI Imp 1, 2, 3	Output 3 mA
Ref Imp 1, 2, 3	Output 4 mA
Raw 1, 2, 3	Output 1 %
mV Input 1, 2, 3	Output 2 %
Temp 1, 2, 3	Output 3 %
Man Temp 1, 2, 3	Output 4 %
Measure 1, 2, 3	Blank

Fault and Warning banner:

If the analyzer detects a problem with itself or the sensor the word Fault or Warning will appear at the bottom of the display. A fault requires immediate attention. A warning indicates a problematic condition or an impending failure. For troubleshooting assistance, press Diag.

Formatting the Main Display

The main display screen can be programmed to show primary process variables, secondary process variables and diagnostics.

1. Press MENU
2. Scroll down to **Display**. Press ENTER.
3. **Main Format** will be highlighted. Press ENTER.
4. The sensor 1 process value will be highlighted in reverse video. Press the selection keys to navigate down to the screen sections that you wish to program. Press **ENTER**.
5. Choose the desired display parameter or diagnostic for each of the four display sections in the lower screen.
6. Continue to navigate and program all desired screen sections. Press **MENU** and **EXIT**. The screen will return to the main display.

For single sensor configurations, the default display shows the live process measurement in the upper display area and temperature in the center display area. The user can elect to disable the display of temperature in the center display area using the Main Format function. See Fig. 4-1 to guide you through programming the main display to select process parameters and diagnostics of your choice.

For dual sensor configurations, the default display shows Sensor 1 live process measurement in the display area 1 and Sensor 2 live process measurement temperature in the display area 2. See Fig. 4-1 to guide you through programming the main display to select process parameters and diagnostics of your choice.

4.4 MENU SYSTEM

Model 1057 uses a scroll and select menu system. Pressing the MENU key at any time opens the top-level menu including Calibrate, Hold, Program and Display functions.

To find a menu item, scroll with the up and down keys until the item is highlighted. Continue to scroll and select menu items until the desired function is chosen. To select the item, press ENTER. To return to a previous menu level or to enable the main live display, press the EXIT key repeatedly. To return immediately to the main display from any menu level, simply press MENU then EXIT.

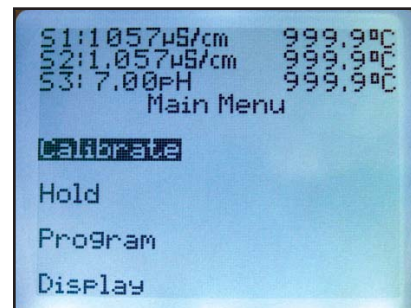

The selection keys have the following functions:

- The Up key (above ENTER) increments numerical values, moves the decimal place one place to the right, or selects units of measurement.
- The Down key (below ENTER) decrements numerical values, moves the decimal place one place to the left, or selects units of measurement
- The Left key (left of ENTER) moves the cursor to the left.
- The Right key (right of ENTER) moves the cursor to the right.

To access desired menu functions, use the "Quick Reference" Figure B. During all menu displays (except main display format and Quick Start), the live process measurements and secondary measurement values are displayed in the top two lines of the Upper display area. This conveniently allows display of the live values during important calibration and programming operations.

Menu screens will time out after two minutes and return to the main live display.

FIGURE 4-1 Formatting the Main Display

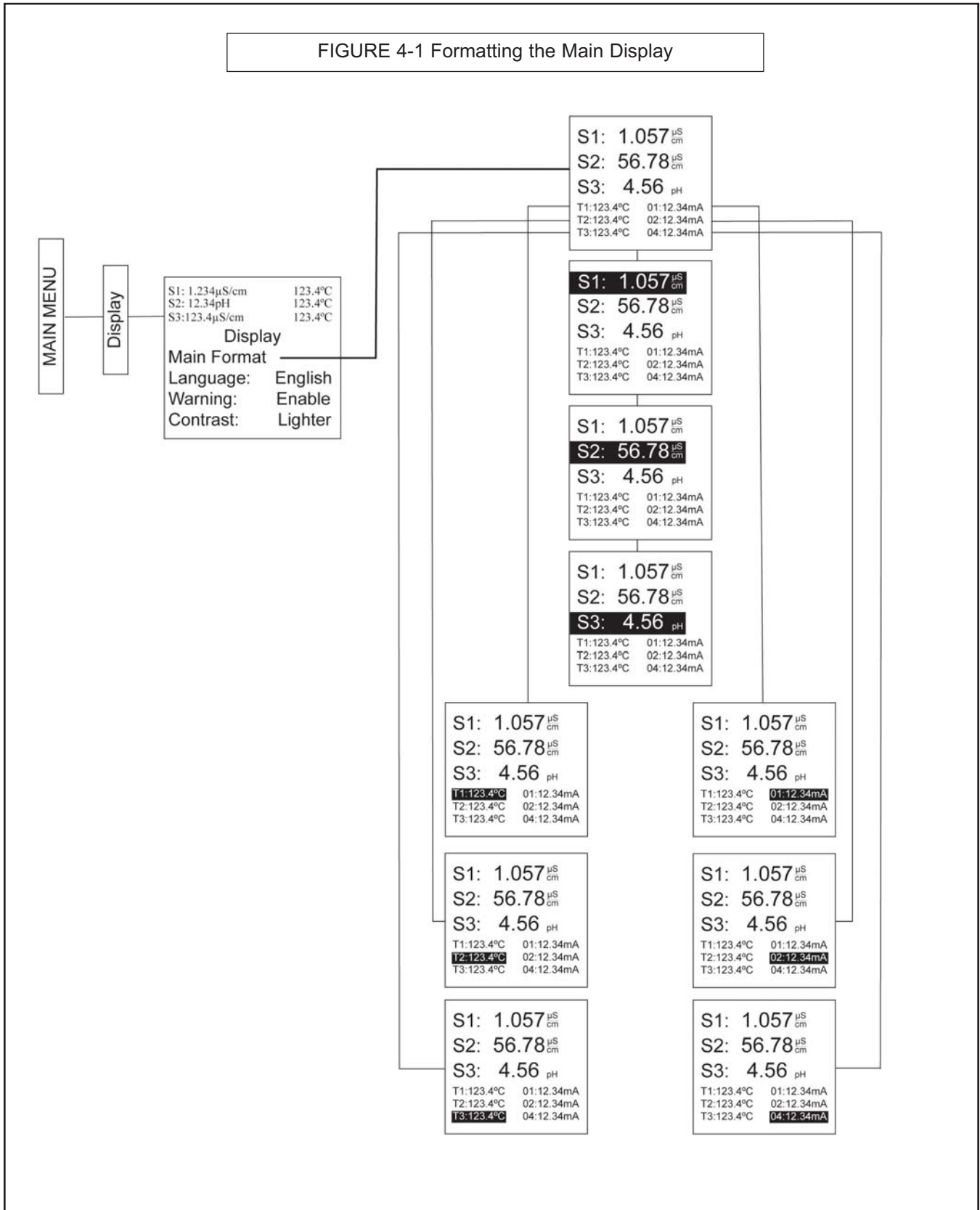

SECTION 5.0. PROGRAMMING THE ANALYZER - BASICS

5.1 GENERAL

5.2 CHANGING START-UP SETTINGS

5.3 PROGRAMMING TEMPERATURE

5.4 CONFIGURING AND RANGING 4-20MA OUTPUTS

5.5 SETTING SECURITY CODES

5.6 SECURITY ACCESS

5.7 USING HOLD

5.8 RESETTING FACTORY DEFAULTS – RESET ANALYZER

5.9 PROGRAMMING ALARM RELAYS

5.1 GENERAL

Section 5.0 describes the following programming functions:

- Changing the measurement type, measurement units and temperature units.
- Choose temperature units and manual or automatic temperature compensation mode
- Configure and assign values to the current outputs
- Set a security code for two levels of security access
- Accessing menu functions using a security code
- Enabling and disabling Hold mode for current outputs
- Choosing the frequency of the AC power (needed for optimum noise rejection)
- Resetting all factory defaults, calibration data only, or current output settings only

5.2 CHANGING STARTUP SETTINGS

5.2.1 Purpose

To change the measurement type, measurement units, or temperature units that were initially entered in Quick Start, choose the Reset analyzer function (Sec. 5.8) or access the Program menus for sensor 1, 2 or 3 (Sec. 6.0). The following choices for specific measurement type, measurement units are available for each sensor measurement board.

TABLE 5-1. Measurements and Measurement Units

Signal board	Available measurements	Measurements units:
pH/ORP (-22, -32, -42)	pH, ORP, Redox, Ammonia, Fluoride, Custom ISE	pH, mV (ORP) %, ppm, mg/L, ppb, µg/L, (ISE)
Contacting conductivity (-20, -30, -40)	Conductivity, Resistivity, TDS, Salinity, NaOH (0-12%), HCl (0-15%), Low H ₂ SO ₄ , High H ₂ SO ₄ , NaCl (0-20%), Custom Curve	µS/cm, mS/cm, S/cm % (concentration)
Temperature (all)	Temperature	°C, °F

5.2.2 Procedure.

Follow the Reset Analyzer procedure (Sec 5.8) to reconfigure the analyzer to display new measurements or measurement units. To change the specific measurement or measurement units for each signal board type, refer to the Program menu for the appropriate measurement (Sec. 6.0).

5.3 CHOOSING TEMPERATURE UNITS AND AUTOMATIC/MANUAL TEMPERATURE COMPENSATION

5.3.1 Purpose

Most liquid analytical measurements (except ORP) require temperature compensation. The Model 1057 performs temperature compensation automatically by applying internal temperature correction algorithms. Temperature correction can also be turned off. If temperature correction is off, the Model 1057 uses the temperature entered by the user in all temperature correction calculations.

5.3.2 Procedure.

Follow the menu screens in Fig. 5.1 to select automatic or manual temp compensation, set the manual reference temperature, and to program temperature units as °C or °F.

S1: 1.234µS/cm	123.4°C
S2: 12.34pH	123.4°C
S3: 123.4µS/cm	123.4°C
Temperature	
Units:	°C
S1 Temp Comp:	Auto
S2 Temp Comp:	Auto
S3 Temp Comp:	Auto

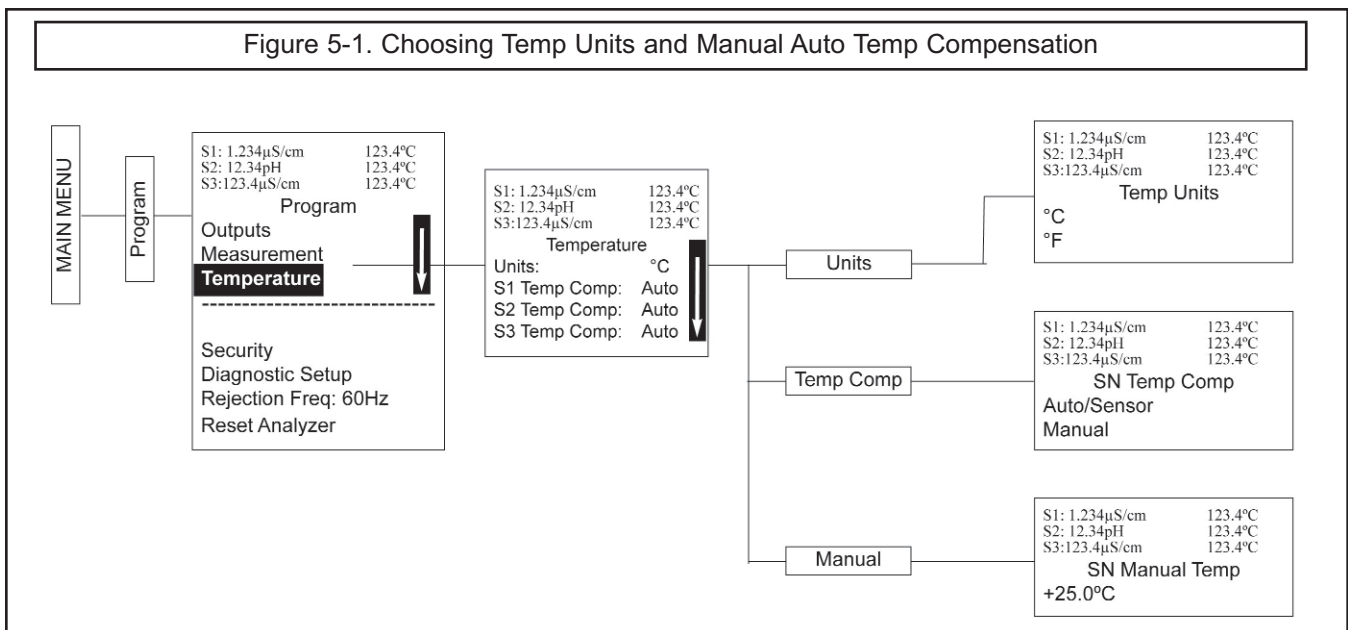

5.4 CONFIGURING AND RANGING THE CURRENT OUTPUTS

5.4.1 Purpose

The Model 1057 accepts inputs from three sensors and has four analog current outputs. Ranging the outputs means assigning values to the low (0 or 4 mA) and high (20 mA) outputs. This section provides a guide for configuring and ranging the outputs. ALWAYS CONFIGURE THE OUTPUTS FIRST.

5.4.2 Definitions

1. CURRENT OUTPUTS. The analyzer provides a continuous output current (4-20 mA or 0-20 mA) directly proportional to the process variable or temperature.

The low and high current outputs can be set to any value.

2. ASSIGNING OUTPUTS. Assign a measurement to Outputs 1, 2, 3, or 4.

3. DAMPEN. Output dampening smooths out noisy readings. It also increases the response time of the output. Output dampening does not affect the response time of the display.

4. MODE. The current output can be made directly proportional to the displayed value (linear mode) or directly proportional to the common logarithm of the displayed value (log mode).

5.4.3 Procedure: Configure Outputs.

Under the Program/Outputs menu, the adjacent screen will appear to allow configuration of the outputs. Follow the menu screens in Fig. 5-2 to configure the outputs.

S1: 1.234µS/cm	123.4°C
S2: 12.34pH	123.4°C
S3:123.4µS/cm	123.4°C

OutputM Configure

Assign: S1 Meas
Range: 4-20mA
Scale: Linear
Dampening: 0sec

Fault Mode: Fixed
Fault Value: 21.00mA

5.4.4 Procedure: Assigning Measurements the Low and High Current Outputs

The adjacent screen will appear when entering the Assign function under Program/Output/Configure. These screens allow you to assign a measurement, process value, or temperature input to each output. Follow the menu screens in Fig. 5-2 to assign measurements to the outputs.

S1: 1.234µS/cm	123.4°C
S2: 12.34pH	123.4°C
S3:123.4µS/cm	123.4°C

OutputM Assign

S1 Measurement
S1 Temperature
S2 Measurement
S2 Temperature.....
S3 Measurement
S3 Temperature

5.4.5 Procedure: Ranging the Current Outputs

The adjacent screen will appear under Program/Output/Range. Enter a value for 4mA and 20mA (or 0mA and 20mA) for each output. Follow the menu screens in Fig. 5-2 to assign values to the outputs.

S1: 1.234µS/cm	123.4°C
S2: 12.34pH	123.4°C
S3:123.4µS/cm	123.4°C

Output Range

OM SN 4mA: 0.00µS/cm
OM SN 20mA: 20.00µS/cm
OM SN 4mA: 00.00pH
OM SN 20mA: 14.00pH

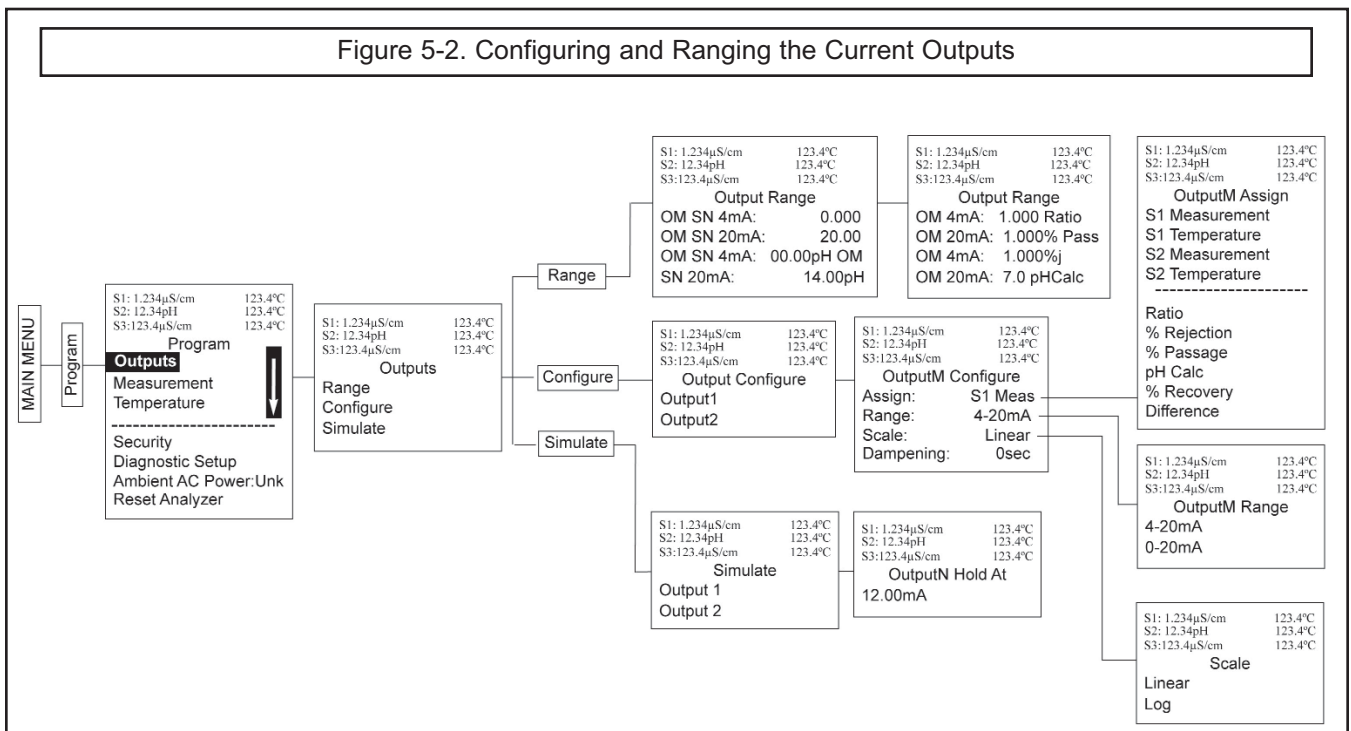

5.5 SETTING A SECURITY CODE

5.5.1 Purpose.

The security codes prevent accidental or unwanted changes to program settings, displays, and calibration. Model 1057 has two levels of security code to control access and use of the instrument to different types of users. The two levels of security are:

- **All:** This is the Supervisory security level. It allows access to all menu functions, including Programming, Calibration, Hold and Display.
- **Calibration/Hold:** This is the operator or technician level menu. It allows access to only calibration and Hold of the current outputs.

2. Scroll down to Security. Select **Security**.
3. The security entry screen appears. Enter a three digit security code for each of the desired security levels. The security code takes effect two minutes after the last key stroke. Record the security code(s) for future access and communication to operators or technicians as needed.
4. The display returns to the security menu screen. Press EXIT to return to the previous screen. To return to the main display, press MENU followed by EXIT.

Fig. 5-3 displays the security code screens.

5.5.2 Procedure.

1. Press MENU. The main menu screen appears. Choose **Program**.

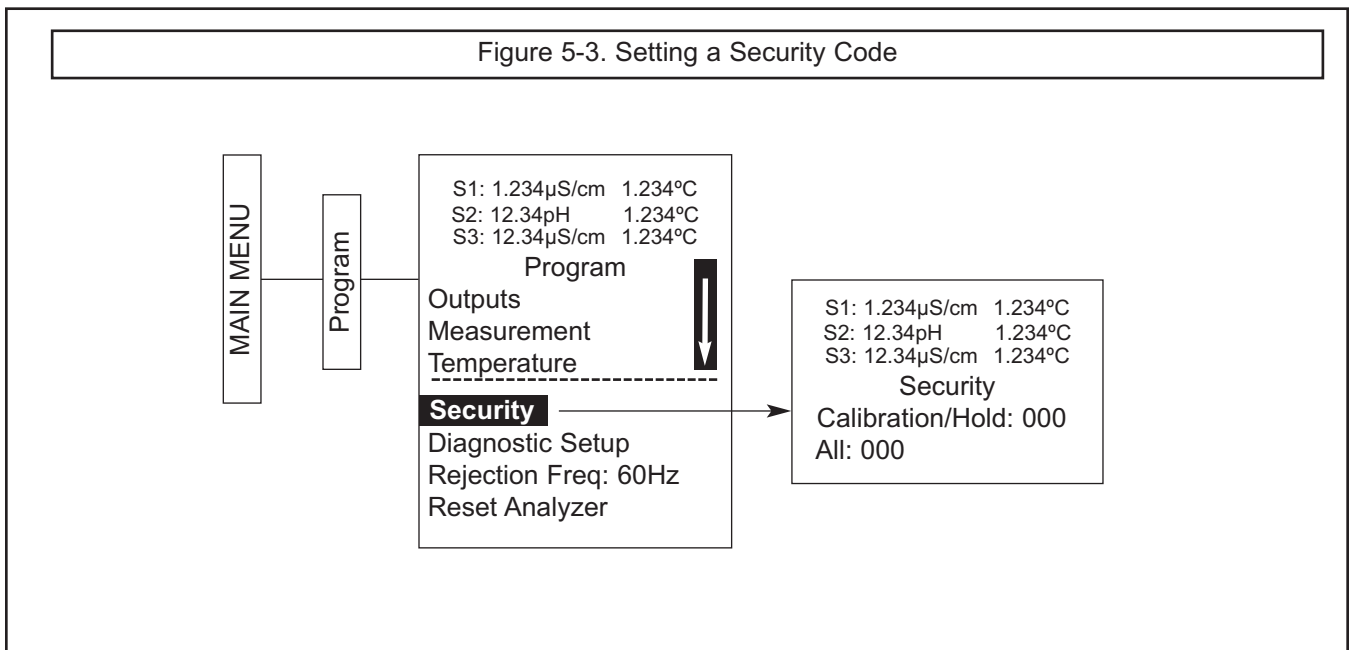

5.6 SECURITY ACCESS

5.6.1 How the Security Code Works

When entering the correct access code for the **Calibration/Hold** security level, the Calibration and Hold menus are accessible. This allows operators or technicians to perform routine maintenance. This security level does not allow access to the Program or Display menus.

When entering the correct access code for **All** security level, the user has access to all menu functions, including Programming, Calibration, Hold and Display.

5.6.2 Procedure.

1. If a security code has been programmed, selecting the Calibrate, Hold, Program or Display top menu items causes the security access screen to appear
2. Enter the three-digit security code for the appropriate security level.

S1: 1.234 μ S/cm	1.234 $^{\circ}$ C
S2: 12.34pH	1.234 $^{\circ}$ C
S3: 12.34 μ S/cm	1.234 $^{\circ}$ C
Security Code	
000	

3. If the entry is correct, the appropriate menu screen appears. If the entry is incorrect, the **Invalid Code** screen appears. The **Enter Security Code** screen reappears after 2 seconds.

5.7 USING HOLD

5.7.1 Purpose

The analyzer output is always proportional to measured value. To prevent improper operation of systems or pumps that are controlled directly by the current output, place the analyzer in hold before removing the sensor for calibration and maintenance. Be sure to remove the analyzer from hold once calibration is complete. During hold, both outputs remain at the last value. **Once in hold, all current outputs remain on Hold indefinitely.**

5.7.2 Using the Hold Function

To hold the outputs,

1. Press MENU. The main menu screen appears. Choose **Hold**.
2. The **Hold Outputs and Alarms?** screen appears. Choose **Yes** to place the analyzer in hold. Choose **No** to take the analyzer out of hold.
Note: There are no alarm relays with this configuration. Current outputs are included with all configurations.
3. The Hold screen will then appear and **Hold will remain on indefinitely until Hold is disabled**.

See figure 5-1 below.

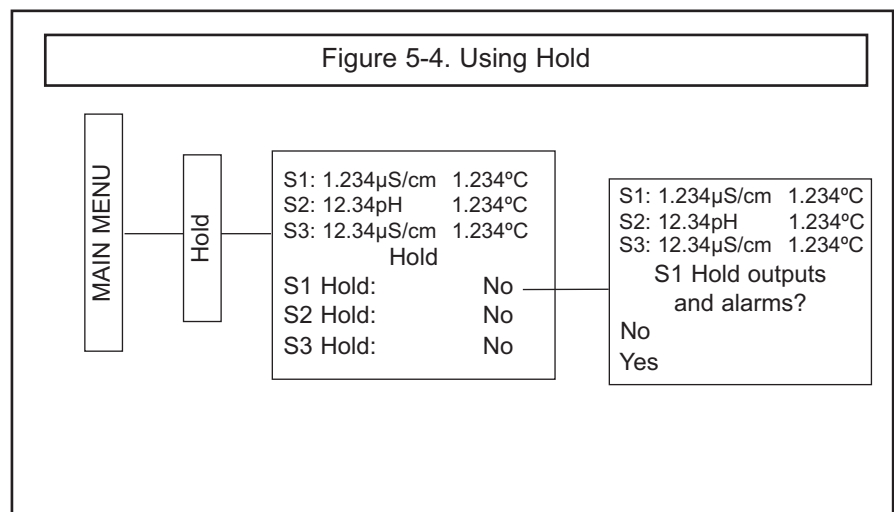

5.8 RESETTING FACTORY DEFAULT SETTINGS

5.8.1 Purpose.

This section describes how to restore factory calibration and default values. The process also clears all fault messages and returns the display to the first Quick Start screen. The Model 1057 offers three options for resetting factory defaults.

- a. reset all settings to factory defaults
- b. reset sensor calibration data only
- c. reset output calibration only

5.8.2 Procedure.

To reset to factory defaults, reset calibration data only or reset analog outputs only, follow the Reset Analyzer flow diagram.

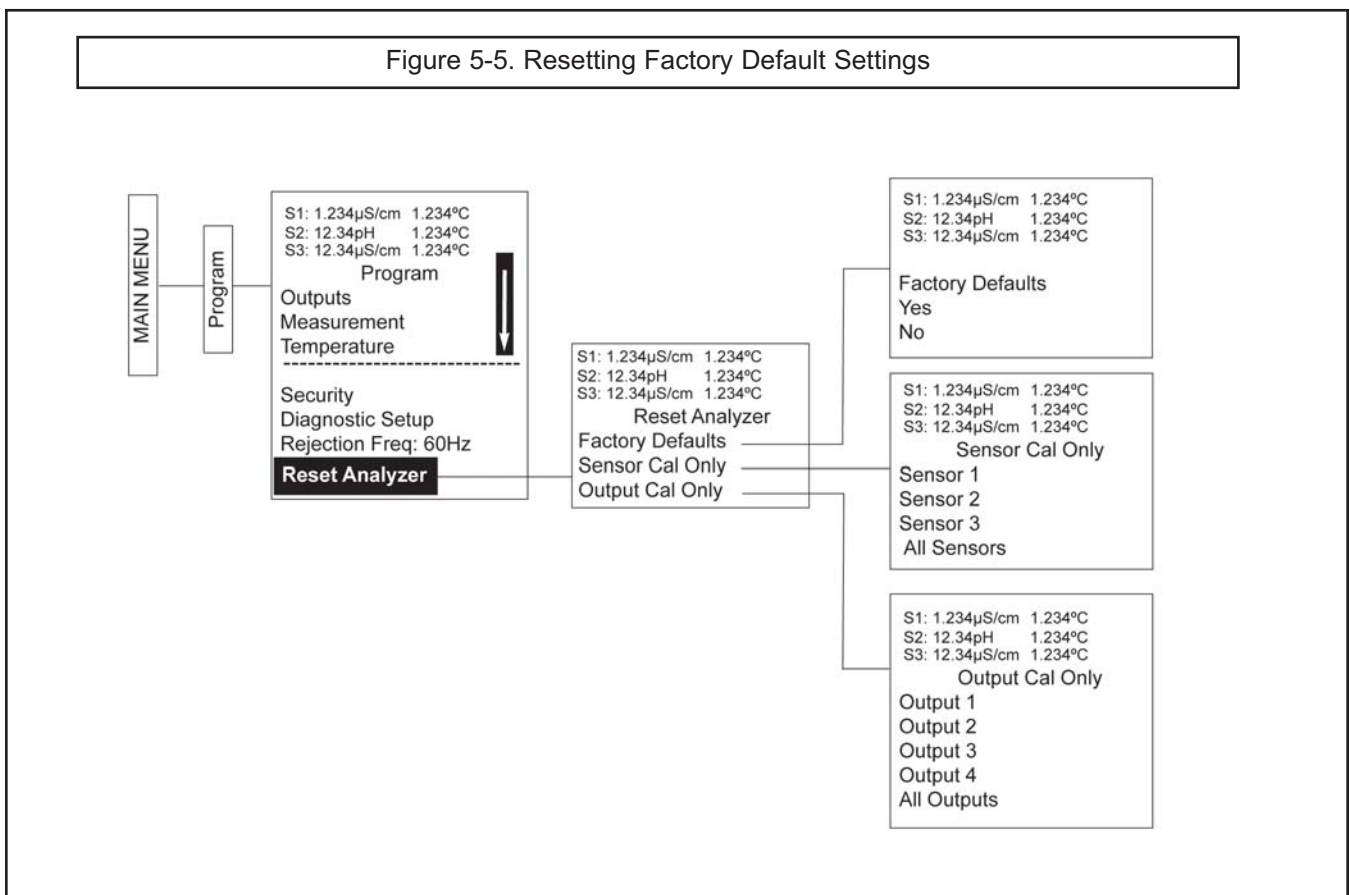

5.9 Programming Alarm Relays

5.9.1 Purpose.

The Model 1057 24VDC (-02 order code) and the AC switching power supply (-03 order code) provide four alarm relays for process measurement or temperature. Each alarm can be configured as a fault alarm instead of a process alarm. Also, each relay can be programmed independently and each can be programmed as an interval timer. This section describes how to configure alarm relays, simulate relay activation, and synchronize timers for the four alarm relays. This section provides details to program the following alarm features:

Sec.	Alarm relay feature:	default	Description
5.9.2	Enter Setpoint	100.0uS/cm	Enter alarm trigger value
5.9.3	Assign measurement	S1 Measure	Select alarm assignment
5.9.4	Set relay logic	High	Program relay to activate at High or Low reading
5.9.5	Deadband:	0.00uS/cm	Program the change in process value after the relay deactivates
5.9.6	USP Safety:	0%↓	Program percentage of the limit to activate the alarm
5.9.7	Normal state:	Open	Program relay default condition as open or closed for failsafe operation
5.9.8	Interval time:	24.0 hr	Time in hours between relay activations
5.9.9	On-Time:	10 min	Enter the time in seconds that the relay is activated.
5.9.10	Recover time:	60 sec	Enter time after the relay deactivation for process recovery
5.9.11	Hold while active:	S1	Holds current outputs during relay activation
5.9.12	Simulate		Manually simulate alarms to confirm relay operation
5.9.13	Synchronize Timers	Yes	Control the timing of two or more relay timers set as Interval timers

Under the **Program/Alarms** menu, this screen will appear to allow configuration of the alarm relays. Follow the menu screens in Fig. XX to configure the outputs.

S1: 1.234μS/cm	1.234°C
S2: 12.34pH	1.234°C
S3: 12.34μS/cm	1.234°C
Alarms	
Configure/Setpoint	
Simulate	
Synchronize Timers: Yes	

This screen will appear to allow selection of a specific alarm relay. Select the desired alarm and press ENTER.

S1: 1.234μS/cm	1.234°C
S2: 12.34pH	1.234°C
S3: 12.34μS/cm	1.234°C
Configure/Setpoint	
Alarm 1	
Alarm 2	
Alarm 3	
Alarm 4	

This screen will appear next to allow complete programming of each alarm. Factory defaults are displayed as they would appear for an installed contacting conductivity board. USP Safety only appears if alarm logic is set to "USP". Interval timer, On Time, Recover Time, and Hold While Active only appear if the alarm is configured as an Interval timer.

S1: 1.234μS/cm	1.234°C
S2: 12.34pH	1.234°C
S3: 12.34μS/cm	1.234°C
AlarmM Settings	
Setpoint:	100.0uS/cm
Assign:	S1 Measure
Logic:	High
Deadband:	0.00uS/cm
USP Safety:	0%↓
Interval time:	24.0 hr
On Time:	120 sec
Recover time:	60 sec
Hold while active:	Sens1

5.9.2 Procedure – Enter Setpoints

Under the Program/Alarms menu, this screen will appear to allow configuration of the alarm relays. Enter the desired value for the process measurement or temperature at which to activate an alarm event.

S1: 1.234µS/cm	1.234°C
S2: 12.34pH	1.234°C
S3: 12.34µS/cm	1.234°C
Alarm1 S2 Setpoint	
+100.0uS/cm	

5.9.3 Procedure – Assign Measurement

Under the Alarms Settings menu, this screen will appear to allow assignment of the alarm relays. select an alarm assignment. Additional assignment choices are shown in Figure X-X depending on which measurement board(s) is installed.

S1: 1.234µS/cm	1.234°C
S2: 12.34pH	1.234°C
S3: 12.34µS/cm	1.234°C
AlarmM Assign:	
S1 Measurement	
S1 Temperature	
S2 Measurement	
S2 Temperature	

S3 Measurement	
S3 Temperature	
Interval Timer	
Fault	
Off	

5.9.4 Procedure – Set Relay Logic

Under the **Alarms Settings** menu, this screen will appear to set the alarm logic. Select the desired relay logic to activate alarms at a High reading or a Low reading. USP Safety only appears if a contacting conductivity board is installed.

S1: 1.234µS/cm	1.234°C
S2: 12.34pH	1.234°C
S3: 12.34µS/cm	1.234°C
AlarmM Logic:	
High	
Low	
USP	

5.9.5 Procedure – Deadband

Under the Alarms Settings menu, this screen will appear to program the deadband as a measurement value. Enter the change in the process value needed after the relay deactivates to return to normal (and thereby preventing repeated alarm activation).

S1: 1.234µS/cm	1.234°C
S2: 12.34pH	1.234°C
S3: 12.34µS/cm	1.234°C
Alarm1 Deadband	
+000.5uS/cm	

5.9.6 Procedure – USP Safety

Under the Alarms Settings menu, this screen will appear to program the USP alarm setting. Enter the percentage below the limit at which to activate the alarm.

S1: 1.234µS/cm	1.234°C
S2: 12.34pH	1.234°C
S3: 12.34µS/cm	1.234°C
Alarm1 USP Safety	
+0%↓	

5.9.7 Procedure – Normal state

The user can define failsafe condition in software by programming the alarm default state to normally open or normally closed upon power up. To display this alarm configuration item, enter the Expert menus by holding down the EXIT key for 6 seconds while in the main display mode. Select Yes upon seeing the screen prompt: “Enable Expert Menu?”

Under the Alarms Settings menu, this screen will appear to set the normal state of the alarms. Select the alarm condition that is desired each time the analyzer is powering up.

S1: 1.234µS/cm	1.234°C
S2: 12.34pH	1.234°C
S3: 12.34µS/cm	1.234°C
Alarm2 Normal State	
Open	
Closed	

5.9.8 Procedure – Interval time

Under the Alarms Settings menu, this screen will appear to set the interval time. Enter the fixed time in hours between relay activations.

S1: 1.234µS/cm	1.234°C
S2: 12.34pH	1.234°C
S3: 12.34µS/cm	1.234°C
Alarm1 Interval Time	
024.0 hrs	

5.9.9 Procedure – On time

Under the Alarms Settings menu, this screen will appear to set the relay on time. Enter the time in seconds that the relay is activated.

S1: 1.234µS/cm	1.234°C
S2: 12.34pH	1.234°C
S3: 12.34µS/cm	1.234°C
Alarm1 On-Time	
00.00sec	

5.9.10 Procedure – Recovery time

Under the Alarms Settings menu, this screen will appear to set the relay recovery time. Enter time after the relay deactivation for process recovery.

S1: 1.234µS/cm	1.234°C
S2: 12.34pH	1.234°C
S3: 12.34µS/cm	1.234°C
Alarm1 Recovery	
060sec	

5.9.11 Procedure – Hold while active

Under the Alarms Settings menu, this screen will appear to program the feature that Holds the current outputs while alarms are active. Select to hold the current outputs for Sensor 1, Sensor 2 or both sensors while the relay is activated.

S1: 1.234µS/cm	1.234°C
S2: 12.34pH	1.234°C
S3: 12.34µS/cm	1.234°C
Alarm1 Hold while active	
Sensor 1	
Sensor 2	
Sensor 3	
All	
None	

5.9.12 Procedure – Simulate

Alarm relays can be manually set for the purposes of checking devices such as valves or pumps. Under the Alarms Settings menu, this screen will appear to allow manual forced activation of the alarm relays. Select the desired alarm condition to simulate.

S1: 1.234µS/cm	1.234°C
S2: 12.34pH	1.234°C
S3: 12.34µS/cm	1.234°C
Simulate Alarm M	
Don't simulate	
De-energize	
Energize	

5.9.13 Procedure – Synchronize

Under the Alarms Settings menu, this screen will appear to allow Synchronization of alarms that are set to Interval Timers. Select yes or no to Synchronize two or more timers.

S1: 1.234µS/cm	1.234°C
S2: 12.34pH	1.234°C
S3: 12.34µS/cm	1.234°C
Synchronize Timers	
Yes	
No	

SECTION 6.0

PROGRAMMING - MEASUREMENTS

6.1 CONFIGURING MEASUREMENTS – INTRODUCTION

6.2 pH

6.3 ORP

6.4 CONTACTING CONDUCTIVITY

6.1 PROGRAMMING MEASUREMENTS – INTRODUCTION

The Model 1057 automatically recognizes each installed measurement board upon first power-up and each time the analyzer is powered. Completion of Quick Start screens upon first power up enable measurements, but additional steps may be required to program the analyzer for the desired measurement application. This section covers the following programming and configuration functions;

1. Selecting measurement type or sensor type (all sections)
2. Identifying the preamp location (pH-see Sec. 6.2)
3. Enabling manual temperature correction and entering a reference temperature (all sections)
4. Enabling sample temperature correction and entering temperature correction slope (selected sections)
5. Defining measurement display resolution (pH)
6. Defining measurement display units (all sections)
7. Adjusting the input filter to control display and output reading variability or noise (all sections)
8. Selecting a measurement range (conductivity – see Sec's 6.4, 6.5)
9. Entering a cell constant for a contacting sensor (see Sec's 6.4, 6.5)
10. Entering a temperature element/RTD offset or temperature slope (conductivity-see Sec's 6.4)
11. Creating an application-specific concentration curve (conductivity-see Sec's 6.4, 6.5)

To fully configure the analyzer for each installed measurement board, you may use the following:

1. Reset Analyzer function to reset factory defaults and configure the measurement board to the desired measurement. Follow the Reset Analyzer menu (Fig. 5-5) to reconfigure the analyzer to display new measurements or measurement units.
2. Program menus to adjust any of the programmable configuration items. Use the following configuration and programming guidelines for the applicable measurement.

6.2 pH MEASUREMENT PROGRAMMING

6.2.1 Description

This section describes how to configure the Model 1057 analyzer for pH measurements. The following programming and configuration functions are covered.

TABLE 6-1. pH Measurement Programming

Measure	Sec.	Menu function:	default setting	Description
pH	6.2.2	Measurement type:	pH	Select pH, ORP, Redox, Ammonia, Fluoride, Custom ISE
	6.2.3	Preamp location:	Analyzer	Identify preamp location
	6.2.4	Solution temperature correction	Off	Select Off, ultra-pure, high pH, custom
	6.2.5	Temp coefficient	(custom)	Enter the temp coefficient
	6.2.6	Resolution:	0.01pH	Select 0.01pH or 0.1pH for pH display resolution
	6.2.7	Filter:	4 sec	Override the default input filter, enter 0-999 seconds
	6.2.8	Reference Z:	Low	Select low or high reference impedance

A detailed flow diagram for pH programming is provided at the end of Sec. 6 to guide you through all basic programming and configuration functions.

To configure the pH measurement board:

1. Press **MENU**
2. Scroll down to **Program**. Press ENTER.
3. Scroll down to Measurement. Press ENTER.
4. Select **Sensor 1** or **Sensor 2** corresponding to pH. Press ENTER.

The adjacent screen format will appear (factory defaults are shown). To program any function, scroll to the desired item and press ENTER.

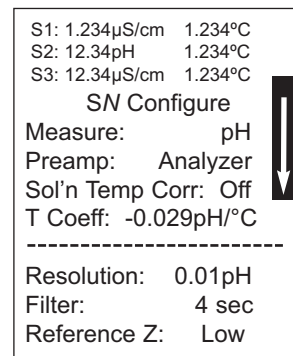

The following sub-sections provide you with the initial display screen that appears for each configuration function. Use the **flow diagram for pH programming** at the end of Sec. 6 and the Model 1057 live screen prompts for each function to complete configuration and programming.

6.2.2 Measurement

The display screen for selecting the measurement is shown. The default value is displayed in **bold type**. Refer to the pH/ORP Programming flow diagram to complete this function.

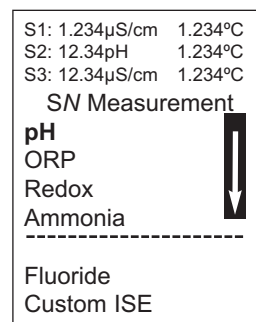

6.2.3 Preamp

The display screen for identifying the Preamp location is shown. The default value is displayed in **bold type**. Refer to the pH/ORP Programming flow diagram to complete this function.

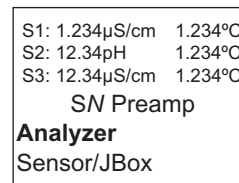

6.2.4 Solution Temperature Correction

The display screen for selecting the Solution temperature correction algorithm is shown. The default value is displayed in **bold type**. Refer to the pH/ORP Programming flow diagram to complete this function.

S1: 1.234µS/cm 1.234°C
S2: 12.34pH 1.234°C
S3: 12.34µS/cm 1.234°C
SN Sol'n Temp Corr.
Off
Ultra Pure Water
High pH
Custom

6.2.5 Temperature Coefficient

The display screen for entering the custom solution temperature coefficient is shown. The default value is displayed in **bold type**. Refer to the pH/ORP Programming flow diagram to complete this function.

S1: 1.234µS/cm 1.234°C
S2: 12.34pH 1.234°C
S3: 12.34µS/cm 1.234°C
SN Sol'n Temp Coeff.
- 0.032pH/°C

6.2.6 Resolution

The display screen for selecting 0.01pH or 0.1pH for pH display resolution is shown. The default value is displayed in **bold type**. Refer to the pH/ORP Programming flow diagram to complete this function.

S1: 1.234µS/cm 1.234°C
S2: 12.34pH 1.234°C
S3: 12.34µS/cm 1.234°C
SN Resolution
0.01pH
0.1pH

6.2.7 Filter

The display screen for entering the input filter value in seconds is shown. The default value is displayed in **bold type**. Refer to the pH/ORP Programming flow diagram to complete this function.

S1: 1.234µS/cm 1.234°C
S2: 12.34pH 1.234°C
S3: 12.34µS/cm 1.234°C
SN Input filter
04 sec

6.2.8 Reference Impedance

The display screen for selecting Low or High Reference impedance is shown. The default value is displayed in **bold type**. Refer to the pH/ORP Programming flow diagram to complete this function.

S1: 1.234µS/cm 1.234°C
S2: 12.34pH 1.234°C
S3: 12.34µS/cm 1.234°C
SN Reference Z
Low
High

6.3 ORP MEASUREMENT PROGRAMMING

6.3.1 Description

The section describes how to configure the Model 1057 analyzer for ORP measurements. The following programming and configuration functions are covered:

TABLE 6-2. ORP Measurement Programming

Measure	Sec.	Menu function:	default	Description
ORP	6.3.2	Measurement type:	pH	Select pH, ORP, Redox, Ammonia, Fluoride, Custom ISE
	6.3.3	Preamp location:	Analyzer	Identify preamp location
	6.3.4	Filter:	4 sec	Override the default input filter, enter 0-999 seconds
	6.3.5	Reference Z:	Low	Select low or high reference impedance

A detailed flow diagram for ORP programming is provided at the end of Sec. 6 to guide you through all basic programming and configuration functions.

To configure the ORP measurement board:

1. Press **MENU**
2. Scroll down to **Program**. Press ENTER.
3. Scroll down to **Measurement**. Press ENTER.
4. Select **Sensor 1** or **Sensor 2** corresponding to ORP. Press ENTER.

The adjacent screen format will appear (factory defaults are shown). To program any displayed function, scroll to the desired item and press ENTER.

S1: 1.234µS/cm	1.234°C
S2: 12.34pH	1.234°C
S3: 12.34µS/cm	1.234°C
SN Configure	
Measure:	pH
Preamp:	Analyzer
Filter:	4 sec
Reference Z:	Low

The following sub-sections provide you with the initial display screen that appears for each configuration function. Use the **flow diagram for ORP programming** at the end of Sec. 6 and the Model 1057 live screen prompts for each function to complete configuration and programming.

6.3.2 Measurement

The display screen for selecting the measurement is shown. The default value is displayed in **bold type**. Refer to the pH/ORP Programming flow diagram to complete this function.

S1: 1.234µS/cm	1.234°C
S2: 12.34pH	1.234°C
S3: 12.34µS/cm	1.234°C
SN Measurement	
pH	
ORP	
Redox	
Ammonia-----	
Fluoride	
Custom ISE	

6.3.3 Preamp

The display screen for identifying the Preamp location is shown. The default value is displayed in **bold type**. Refer to the pH/ORP Programming flow diagram to complete this function.

S1: 1.234µS/cm	1.234°C
S2: 12.34pH	1.234°C
S3: 12.34µS/cm	1.234°C
SN Preamp	
Analyzer	
Sensor/JBox	

6.3.4 Filter

The display screen for entering the input filter value in seconds is shown. The default value is displayed in **bold type**. Refer to the pH/ORP Programming flow diagram to complete this function.

S1: 1.234µS/cm	1.234°C
S2: 12.34pH	1.234°C
S3: 12.34µS/cm	1.234°C
SN Input filter	
04 sec	

6.3.5 Reference Impedence

The display screen for Selecting Low or high Reference impedance is shown. The default value is displayed in **bold type**. Refer to the pH/ORP Programming flow diagram to complete this function.

S1: 1.234µS/cm	1.234°C
S2: 12.34pH	1.234°C
S3: 12.34µS/cm	1.234°C
SN Reference Z	
Low	
High	

6.4 CONTACTING CONDUCTIVITY MEASUREMENT PROGRAMMING

6.4.1 Description

The section describes how to configure the Model 1057 analyzer for conductivity measurements using contacting conductivity sensors. The following programming and configuration functions are covered.

TABLE 6-3. Contacting Conductivity Measurement Programming

Measure	Sec.	Menu function:	default	Description
Contacting Conductivity	6.4.2	Type:	2-Electrode	Select 2-Electrode or 4-Electrode type sensors
	6.4.3	Measure:	Conductivity	Select Conductivity, Resistivity, TDS, Salinity or % conc
	6.4.4	Range:	Auto	Select measurement Auto-range or specific range
	6.4.5	Cell K:	1.00000/cm	Enter the cell Constant for the sensor
	6.4.6	RTD Offset:	0.00°C	Enter the RTD Offset
	6.4.7	RTD Slope:	0	Enter the RTD Slope
	6.4.8	Temp Comp:	Slope	Select Temp Comp: Slope, Neutral Salt, Cation or Raw
	6.4.9	Slope:	2.00%/°C	Enter the linear temperature coefficient
	6.4.10	Ref Temp:	25.0°C	Enter the Reference temp
	6.4.11	Filter:	2 sec	Override the default input filter, enter 0-999 seconds
	6.4.12	Custom	Setup	Enter 2-5 data points in ppm and μS/cm for custom curves
	6.4.13	Cal Factor:	0.95000/cm	Enter the Cal Factor for 4-Electrode sensors from the sensor tag

A detailed flow diagram for contacting conductivity programming is provided at the end of Sec. 6 to guide you through all basic programming and configuration functions.

To configure the contacting conductivity measurement board:

1. Press **MENU**
2. Scroll down to **Program**. Press ENTER.
3. Scroll down to **Measurement**. Press ENTER.
4. Select **Sensor 1** or **Sensor 2** corresponding to contacting conductivity. Press ENTER.

The adjacent screen format will appear (factory defaults are shown). To program any displayed function, scroll to the desired item and press ENTER.

S1: 1.234μS/cm	1.234°C
S2: 12.34pH	1.234°C
S3: 12.34μS/cm	1.234°C
SN Configure	
Type:	2-Electrode
Measure:	Cond
Range:	Auto
Cell K:	1.00000/cm
RTD Offset:	0.00°C
RTD Slope:	0
Temp Comp:	Slope
Slope:	2.00%/°C
Ref Temp:	25.0°C
Filter:	2 sec
Custom Setup	

The following sub-sections provide you with the initial display screen that appears for each configuration function. Use the **flow diagram for contacting conductivity programming** at the end of Sec. 6 and the Model 1057 live screen prompts for each function to complete configuration and programming.

6.4.2 Sensor Type

The display screen for selecting 2-Electrode or 4-Electrode type sensors is shown. The default value is displayed in **bold type**. Refer to the contacting conductivity Programming flow diagram to complete this function.

S1: 1.234μS/cm	1.234°C
S2: 12.34pH	1.234°C
S3: 12.34μS/cm	1.234°C
SN Type	
2-Electrode	
4-Electrode	

6.4.3 Measure

The display screen for selecting the measurement is shown. The default value is displayed in **bold type**. Refer to the contacting conductivity Programming flow diagram to complete this function.

S1: 1.234μS/cm	1.234°C
S2: 12.34pH	1.234°C
S3: 12.34μS/cm	1.234°C
SN Measurement	
Conductivity	
Resistivity	
TDS	
Salinity	

NaOH (0-12%)	
HCl (0-15%)	
Low H2SO4	
High H2SO4	
NaCl (0-20%)	
Custom Curve	

6.4.4 Range

The display screen for Selecting Auto-ranging or a specific range is shown. The default value is displayed in **bold type**. Note: Ranges are shown as conductance, not conductivity. Refer to the contacting conductivity Programming flow diagram to complete this function.

S1: 1.234μS/cm	1.234°C
S2: 12.34pH	1.234°C
S3: 12.34μS/cm	1.234°C
SN Range	
Auto	
50 μS	
500 μS	
2000 μS	

20 mS	
200 mS	
600 mS	

6.4.5 Cell Constant

The display screen for entering a cell Constant for the sensor is shown. The default value is displayed in **bold type**. Refer to the contacting conductivity Programming flow diagram to complete this function.

S1: 1.234μS/cm	1.234°C
S2: 12.34pH	1.234°C
S3: 12.34μS/cm	1.234°C
SN Cell Constant	
1.00000 /cm	

6.4.6 RTD Offset

The display screen for Entering the RTD Offset for the sensor is shown. The default value is displayed in **bold type**. Refer to the contacting conductivity Programming flow diagram to complete this function.

S1: 1.234μS/cm	1.234°C
S2: 12.34pH	1.234°C
S3: 12.34μS/cm	1.234°C
SN RTD Offset	
0.00°C	

6.4.7 RTD Slope

The display screen for entering the RTD slope for the sensor is shown. The default value is displayed in **bold type**. Refer to the contacting conductivity Programming flow diagram to complete this function.

S1: 1.234μS/cm	1.234°C
S2: 12.34pH	1.234°C
S3: 12.34μS/cm	1.234°C
SN RTD Slope	
2.00%/°C	

6.4.8 Temp Comp

The display screen for Selecting Temperature Compensation as Slope, Neutral Salt, Cation or Raw is shown. The default value is displayed in **bold type**. Refer to the contacting conductivity Programming flow diagram to complete this function.

S1: 1.234μS/cm	1.234°C
S2: 12.34pH	1.234°C
S3: 12.34μS/cm	1.234°C
SN Temp Comp	
Slope	
Neutral Salt	
Cation	
Raw	

6.4.9 Slope

The display screen for Entering the conductivity/temp Slope is shown. The default value is displayed in **bold type**. Refer to the contacting conductivity Programming flow diagram to complete this function.

S1: 1.234µS/cm 1.234°C
S2: 12.34pH 1.234°C
S3: 12.34µS/cm 1.234°C
SN Slope
2.00 %/°C

6.4.10 Reference Temp

The display screen for manually entering the Reference temperature is shown. The default value is displayed in **bold type**. Refer to the contacting conductivity Programming flow diagram to complete this function.

S1: 1.234µS/cm 1.234°C
S2: 12.34pH 1.234°C
S3: 12.34µS/cm 1.234°C
SN Ref Temp
(25.0°C normal)
+25.0°C

6.4.11 Filter

The display screen for entering the input filter value in seconds is shown. The default value is displayed in **bold type**. Refer to the contacting conductivity Programming flow diagram to complete this function.

S1: 1.234µS/cm 1.234°C
S2: 12.34pH 1.234°C
S3: 12.34µS/cm 1.234°C
SN Input filter
02 sec

6.4.12 Custom Setup

The display screens for creating a custom curve for converting conductivity to concentration is shown. Refer to the contacting conductivity Programming flow diagram to complete this function.

S1: 1.234µS/cm 1.234°C
S2: 12.34pH 1.234°C
S3: 12.34µS/cm 1.234°C
SN Custom Curve
Configure
Enter Data Points
Calculate Curve

When the custom curve data entry is complete, press ENTER. The display will confirm the determination of a custom curve fit to the entered data by displaying this screen:

S1: 1.234µS/cm 1.234°C
S2: 12.34pH 1.234°C
S3: 12.34µS/cm 1.234°C
SN Calculate Curve
Custom curve
fit completed.
In Process Cal
recommended.

If the custom curve fit is not completed or is unsuccessful, the display will read as follows and the screen will return to the beginning custom curve screen.

S1: 1.234µS/cm 1.234°C
S2: 12.34pH 1.234°C
S3: 12.34µS/cm 1.234°C
SN Calculate Curve
Failure

6.4.13 Cal Factor

Upon initial installation and power up, if **4-electrode** was selected for the sensor type in the **Quick Start** menus, the user enters a Cell Constant and a “Cal Factor” using the instrument keypad. The cell constant is needed to convert measured conductance to conductivity as displayed on the analyzer screen. The “Cal Factor” entry is needed increase the accuracy of the live conductivity readings, especially at low conductivity readings below 20uS/cm. Both the Cell Constant and the “Cal Factor” are printed on the tag attached to the 4-electrode sensor/cable.

The display screen for entering Cal Factor is shown. The default value is displayed in **bold type**. If necessary after initial installation and start-up, enter the “Cal Factor” as printed on the sensor tag.

S1: 1.234µS/cm 1.234°C
S2: 12.34pH 1.234°C
S3: 12.34µS/cm 1.234°C
SN Cal Factor
0.95000/cm

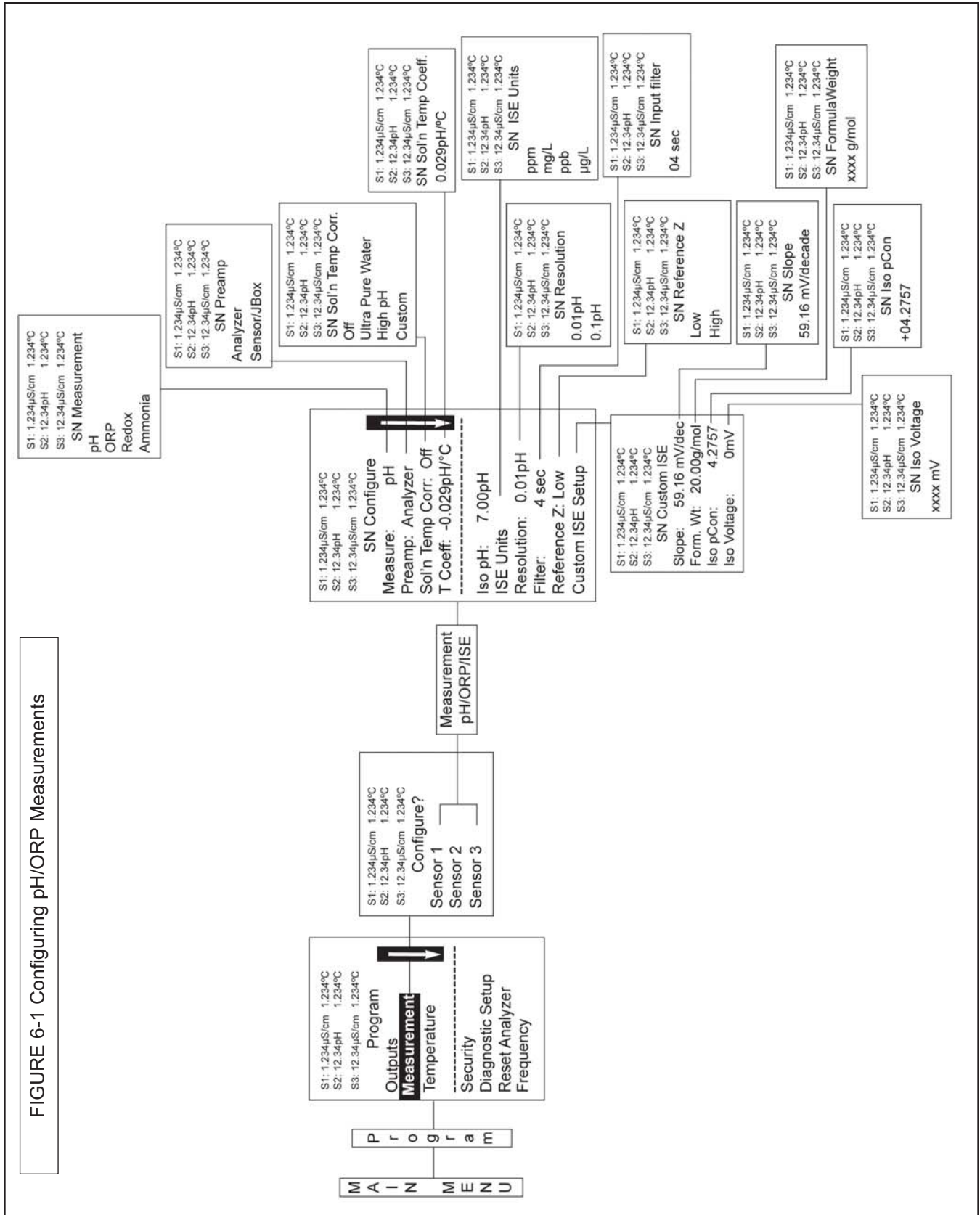

SECTION 7.0 CALIBRATION

7.1 CALIBRATION – INTRODUCTION

7.2 pH CALIBRATION

7.3 ORP CALIBRATION

7.4 CONTACTING CONDUCTIVITY CALIBRATION

7.5 TEMPERATURE CALIBRATION

7.1 CALIBRATION – INTRODUCTION

Calibration is the process of adjusting or standardizing the analyzer to a lab test or a calibrated laboratory instrument, or standardizing to some known reference (such as a commercial buffer).

The auto-recognition feature of the analyzer will enable the appropriate calibration screens to allow calibration for any single sensor configuration or dual sensor configuration of the analyzer. Completion of Quick Start upon first power up enables live measurements but does not ensure accurate readings in the lab or in process. Calibration should be performed with each attached sensor to ensure accurate, repeatable readings.

This section covers the following programming and configuration functions:

1. Auto buffer cal for pH (pH Cal - Sec.7.2)
2. Manual buffer cal for pH (pH Cal - Sec.7.2)
3. Set calibration stabilization criteria for pH (pH Cal - Sec.7.2)
4. Standardization calibration (1-point) for pH, ORP and Redox (pH Cal - Sec.7.2 and 7.3)
5. Entering the cell constant of a conductivity sensor (Conductivity Cal - Sec. 7.4 and 7.5)
6. Calibrating the sensor in a conductivity standard (Conductivity Cal - Sec. 7.4 and 7.5)
7. Calibrating the analyzer to a laboratory instrument (Contacting Conductivity Cal - Sec.7.4)
8. Enter a manual reference temperature for temperature compensation of the process measurement

7.2 pH CALIBRATION

7.2.1 DESCRIPTION

New sensors must be calibrated before use. Regular recalibration is also necessary. Use auto calibration instead of manual calibration. Auto calibration avoids common pitfalls and reduces errors. The analyzer recognizes the buffers and uses temperature-corrected pH values in the calibration. Once the Model 1057 successfully completes the calibration, it calculates and displays the calibration slope and offset. The slope is reported as the slope at 25°C.

THIS SECTION DESCRIBES HOW TO CALIBRATE THE MODEL 1057 WITH A pH SENSOR. THE FOLLOWING CALIBRATION ROUTINES ARE COVERED.

TABLE 7-1 pH Calibration Routines

Measure	Sec.	Menu function:	default	Description
pH	7.2.2	Auto Calibration -	pH	2 point buffer calibration with auto buffer recognition
	7.2.3	Manual Calibration -	pH	2 point buffer calibration with manual buffer value entry
	7.2.4	Entering A Known Slope Value -	pH	Slope calibration with manual entry of known slope value
	7.2.5	Standardization -	pH	1 point buffer calibration with manual buffer value entry

A detailed flow diagram is provided at the end of Sec. 7 to guide you through the calibration routines.

To calibrate pH:

1. Press the **MENU** button
2. Select Calibrate. Press **ENTER**.
3. Select **Sensor 1** or **Sensor 2** corresponding to pH. Press **ENTER**.
4. Select **pH**. Press **ENTER**.

The following screen will appear. To calibrate pH or Temperature scroll to the desired item and press **ENTER**.

S1: 1.234µS/cm	1.234°C
S2: 12.34pH	1.234°C
S3: 12.34µS/cm	1.234°C
SN Calibrate?	
pH	
Temperature	

The following sub-sections show the initial display screen that appears for each calibration routine. Use the **flow diagram for pH calibration** at the end of Sec. 7 and the live screen prompts to complete calibration.

7.2.2 AUTO CALIBRATION — pH

This screen appears after selecting **pH calibration**.

S1: 1.234µS/cm	1.234°C
S2: 12.34pH	1.234°C
S3: 12.34µS/cm	1.234°C
SN pH Cal	
Buffer Cal	
Standardize	
Slope:	59.16mV/pH
Offset:	600 mV

Note that pH auto calibration criteria can be changed. The following criteria can be adjusted:

- Stabilization time (default 10 sec.)
- Stabilization pH value (default 0.02 pH)
- Type of Buffer used for AUTO CALIBRATION (default is Standard, non-commercial buffers).

The following commercial buffer tables are recognized by the analyzer:

- Standard (NIST plus pH7)
- DIN 19267
- Ingold
- Merck

The following screen will appear to allow adjustment of these criteria:

S1: 1.234µS/cm	1.234°C
S2: 12.34pH	1.234°C
S3: 12.34µS/cm	1.234°C
SN Setup	
Stable Time:	10 sec
Stable Delta:	0.02 pH
Buffer:	Standard

The following screen will appear if the auto cal is successful. The screen will return to the pH Buffer Cal Menu.

S1: 1.234µS/cm	1.234°C
S2: 12.34pH	1.234°C
S3: 12.34µS/cm	1.234°C
SN pH Auto Cal	
Slope:	59.16 mV/pH
Offset:	60 mV

The following screens may appear if the auto cal is unsuccessful.

1. A High Slope Error will generate this screen display:

S1: 1.234µS/cm	1.234°C
S2: 12.34pH	1.234°C
S3: 12.34µS/cm	1.234°C
SN pH Auto Cal	
High Slope Error	
Calculated:	62.11 mV/pH
Max:	62.00 mV/pH
Press EXIT	

2. A Low Slope Error will generate this screen display:

```
S1: 1.234µS/cm  1.234°C
S2: 12.34pH    1.234°C
S3: 12.34µS/cm 1.234°C
      SN pH Auto Cal
Low Slope Error
Calculated: 39.11mV/pH
Min: 40.00 mV/pH
Press EXIT
```

3. An Offset Error will generate this screen display:

```
S1: 1.234µS/cm  1.234°C
S2: 12.34pH    1.234°C
S3: 12.34µS/cm 1.234°C
      SN pH Auto Cal
Offset Error
Calculated:  61.22mV
Max:        60.00mV
Press EXIT
```

7.2.3 MANUAL CALIBRATION — pH

New sensors must be calibrated before use. Regular recalibration is also necessary. Use manual calibration if non-standard buffers are being used; otherwise, use auto calibration. Auto calibration avoids common pitfalls and reduces errors.

The adjacent appears after selecting Manual pH calibration.

tion.

```
S1: 1.234µS/cm  1.234°C
S2: 12.34pH    1.234°C
S3: 12.34µS/cm 1.234°C
      SN pH Manual Cal
Buffer 1
Buffer 2
```

7.2.4 ENTERING A KNOWN SLOPE VALUE — pH

If the electrode slope is known from other measurements, it can be entered directly in the Model 1057 analyzer. The slope must be entered as the slope at 25°C.

```
S1: 1.234µS/cm  1.234°C
S2: 12.34pH    1.234°C
S3: 12.34µS/cm 1.234°C
      SN pH Slope@25°C
59.16 mV/pH
```

7.2.5 STANDARDIZATION — pH

The pH measured by the Model 1057 analyzer can be changed to match the reading from a second or referee instrument. The process of making the two readings agree is called standardization. During standardization, the difference between the two pH values is converted to the equivalent voltage. The voltage, called the reference offset, is added to all subsequent measured cell voltages before they are converted to pH. If a standardized sensor is placed in a buffer solution, the measured pH will differ from the buffer pH by an amount equivalent to the standardization offset.

```
S1: 1.234µS/cm  1.234°C
S2: 12.34pH    1.234°C
S3: 12.34µS/cm 1.234°C
      SN Enter Value
07.00pH
```

The following screen may appear if ORP Cal is unsuccessful. An Offset Error will generate this screen display:

If the ORP Cal is successful, the screen will return to the Cal sub-menu.

```
S1: 1.234µS/cm  1.234°C
S2: 12.34pH    1.234°C
S3: 12.34µS/cm 1.234°C
      SN Standardize
Offset Error
Calculated:  96mV
Max:        60mV
Press EXIT
```

7.3 ORP CALIBRATION

7.3.1 DESCRIPTION

For process control, it is often important to make the measured ORP agree with the ORP of a standard solution. During calibration, the measured ORP is made equal to the ORP of a standard solution at a single point.

THIS SECTION DESCRIBES HOW TO CALIBRATE THE MODEL 1057 WITH AN ORP SENSOR. THE FOLLOWING CALIBRATION ROUTINE IS COVERED.

TABLE 7-2 ORP Calibration Routine

Measure	Sec.	Menu function: default	Description
ORP	7.3.2	Standardization — ORP	1 point buffer calibration with manual buffer value entry

A detailed flow diagram is provided at the end of Sec. 7 to guide you through the calibration routines.

To calibrate ORP:

1. Press the MENU button
2. Select Calibrate. Press ENTER.
3. Select Sensor 1 or Sensor 2 corresponding to ORP. Press ENTER.
4. Select ORP. Press ENTER.

The following screen will appear. To calibrate ORP or Temperature, scroll to the desired item and press ENTER.

```
S1: 1.234µS/cm  1.234°C
S2: 12.34pH    1.234°C
S3: 12.34µS/cm 1.234°C
  SN Calibrate?
  ORP
  Temperature
```

The following sub-sections show the initial display screen that appears for each calibration routine. Use the **flow diagram for ORP calibration** at the end of Sec. 7 and the live screen prompts to complete calibration.

7.3.2 STANDARDIZATION — ORP

For process control, it is often important to make the measured ORP agree with the ORP of a standard solution. During calibration, the measured ORP is made equal to the ORP of a standard solution at a single point. This screen appears after selecting ORP calibration:

Cal sub-menu.

```
S1: 1.234µS/cm  1.234°C
S2: 12.34pH    1.234°C
S3: 12.34µS/cm 1.234°C
  SN Enter Value
  +0600 mV
```

If the ORP Cal is successful, the screen will return to the

The following screen may appear if ORP Cal is unsuccessful.

```
S1: 1.234µS/cm  1.234°C
S2: 12.34pH    1.234°C
S3: 12.34µS/cm 1.234°C
  SN Standardize
  Offset Error
  Calculated: 61.22mV
  Max:       60.00mV
  Press EXIT
```

7.4 CONTACTING CONDUCTIVITY CALIBRATION

7.4.1 DESCRIPTION

PLACING A NEW CONDUCTIVITY SENSOR IN SERVICE
New conductivity sensors rarely need calibration. The cell constant printed on the label is sufficiently accurate for most applications.

CALIBRATING AN IN-SERVICE CONDUCTIVITY SENSOR
1. After a conductivity sensor has been in service for a period of time, recalibration may be necessary. There are three ways to calibrate a sensor.

- a. Use a standard instrument and sensor to measure the conductivity of the process stream. It is not necessary to remove the sensor from the process piping. The temperature correction used by the standard instrument may not exactly match the temperature correction used by the Model 1057. To avoid errors, turn off temperature correction in both the analyzer and the standard instrument.
- b. Place the sensor in a solution of known conductivity and make the analyzer reading match the conductivity of the

standard solution. Use this method if the sensor can be easily removed from the process piping and a standard is available. Be careful using standard solutions having conductivity less than 100 $\mu\text{S}/\text{cm}$. Low conductivity standards are highly susceptible to atmospheric contamination. Avoid calibrating sensors with 0.01/cm cell constants against conductivity standards having conductivity greater than 100 $\mu\text{S}/\text{cm}$. The resistance of these solutions may be too low for an accurate measurement. Calibrate sensors with 0.01/cm cell constant using method c.

- c. To calibrate a 0.01/cm sensor, check it against a standard instrument and 0.01/cm sensor while both sensors are measuring water having a conductivity between 5 and 10 $\mu\text{S}/\text{cm}$. To avoid drift caused by absorption of atmospheric carbon dioxide, saturate the sample with air before making the measurements.
To ensure adequate flow past the sensor during calibration, take the sample downstream from the sensor. For best results, use a flow-through standard cell. If the process temperature is much different from ambient, keep connecting lines short and insulate the flow cell.

THIS SECTION DESCRIBES HOW TO CALIBRATE THE MODEL 1057 WITH AN ATTACHED CONTACTING CONDUCTIVITY SENSOR. THE FOLLOWING CALIBRATION ROUTINES ARE COVERED.

TABLE 7-3 Contacting Conductivity Calibration Routines

Measure	Sec.	Menu function:	default	Description
Contacting Conductivity	7.4.2	Cell K:	1.00000/cm	Enter the cell Constant for the sensor
	7.4.3	Zero Cal		Zero the analyzer with the sensor attached
	7.4.4	In Process Cal		Standardize the sensor to a known conductivity
	7.4.5	Meter Cal		Calibrate the analyzer to a lab conductivity instrument
	7.4.6	Cal Factor:	0.95000/cm	Enter the Cal Factor for 4-Electrode sensors from the sensor tag

A detailed flow diagram is provided at the end of Sec. 7 to guide you through the calibration routines

To calibrate contacting conductivity:

1. Press the MENU button
2. Select Calibrate. Press ENTER.
3. Select Sensor 1 or Sensor 2 corresponding to contacting conductivity. Press ENTER.
4. Select Conductivity. Press ENTER.

The adjacent screen will appear. To calibrate Conductivity or Temperature, scroll to the desired item and press ENTER.

```
S1: 1.234 $\mu\text{S}/\text{cm}$  1.234 $^{\circ}\text{C}$ 
S2: 12.34pH 1.234 $^{\circ}\text{C}$ 
S3: 12.34 $\mu\text{S}/\text{cm}$  1.234 $^{\circ}\text{C}$ 
SN Calibrate?
Conductivity
Temperature
```

The following sub-sections show the initial display screen that appears for each calibration routine. Use the **flow diagram for Conductivity calibration** at the end of Sec. 7 and the live screen prompts for each routine to complete calibration.

```
S1: 1.234 $\mu\text{S}/\text{cm}$  1.234 $^{\circ}\text{C}$ 
S2: 12.34pH 1.234 $^{\circ}\text{C}$ 
S3: 12.34 $\mu\text{S}/\text{cm}$  1.234 $^{\circ}\text{C}$ 
SN Calibration
Zero Cal
In Process Cal
Meter Cal
Cell K: 1.00000/cm
```

The adjacent screen appears after selecting **Conductivity calibration**:

7.4.2 ENTERING THE CELL CONSTANT

New conductivity sensors rarely need calibration. The cell constant printed on the label is sufficiently accurate for most applications. The cell constant should be entered:

- When the unit is installed for the first time
- When the probe is replaced

The display screen for entering a cell Constant for the sensor is shown. The default value is displayed in **bold type**.

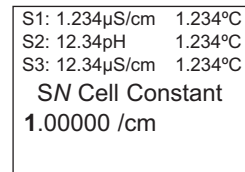

7.4.3 ZEROING THE INSTRUMENT

This procedure is used to compensate for small offsets to the conductivity signal that are present even when there is no conductivity to be measured. This procedure is affected by the length of extension cable and should always be repeated if any changes in extension cable or sensor have been made. **Electrically connect the conductivity probe as it will actually be used and place the measuring portion of the probe in air. Be sure the probe is dry.**

The adjacent screen will appear after selecting **Zero Cal** from the Conductivity Calibration screen:

The adjacent screen will appear if zero Cal is successful. The screen will return to the conductivity Cal Menu.

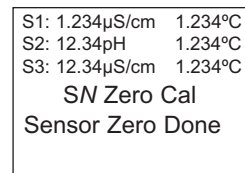
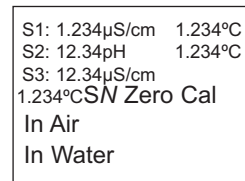

The adjacent screen may appear if zero Cal is unsuccessful.

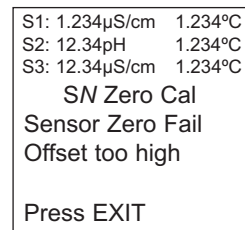

7.4.4 CALIBRATING THE SENSOR IN A CONDUCTIVITY STANDARD (IN PROCESS CAL)

This procedure is used to calibrate the sensor and analyzer against a solution of known conductivity. This is done by submerging the probe in the sample of known conductivity, then adjusting the displayed value, if necessary, to correspond to the conductivity value of the sample. Turn temperature correction off and use the conductivity of the standard. Use a calibrated thermometer to measure temperature. The probe must be cleaned before performing this procedure.

The adjacent screen will appear after selecting **In Process Cal** from the Conductivity Calibration screen:

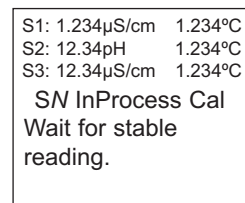

The adjacent screen will appear if In Process Cal is successful. The screen will return to the conductivity Cal Menu.

```
S1: 1.234µS/cm  1.234°C
S2: 12.34pH    1.234°C
S3: 12.34µS/cm 1.234°C
SN InProcess Cal
Updated cell
constant:
1.00135/cm
```

The adjacent screen may appear if In Process Cal is unsuccessful. The screen will return to the conductivity Cal Men

```
S1: 1.234µS/cm  1.234°C
S2: 12.34pH    1.234°C
S3: 12.34µS/cm 1.234°C
SN InProcess Cal
Calibration
Error
Press EXIT
```

7.4.5 CALIBRATING THE SENSOR TO A LABORATORY INSTRUMENT (METER CAL)

This procedure is used to check and correct the conductivity reading of the Model 1057 using a laboratory conductivity instrument. This is done by submerging the conductivity probe in a bath and measuring the conductivity of a grab sample of the same bath water with a separate laboratory instrument. The Model 1057 reading is then adjusted to match the conductivity reading of the lab instrument.

The adjacent screen will appear after selecting **Meter Cal** from the Conductivity Calibration screen:

```
S1: 1.234µS/cm  1.234°C
S2: 12.34pH    1.234°C
S3: 12.34µS/cm 1.234°C
SN Meter Cal
Use precision
resistors only
```

After pressing ENTER, the display shows the live value measured by the sensor

```
S1: 1.234µS/cm  1.234°C
S2: 12.34pH    1.234°C
S3: 12.34µS/cm 1.234°C
SN Enter Value
xx.xx kΩ
```

If the meter cal is successful the screen will return to the conductivity Cal Menu.

```
S1: 1.234µS/cm  1.234°C
S2: 12.34pH    1.234°C
S3: 12.34µS/cm 1.234°C
SN Meter Cal
Calibration
Error
Press EXIT
```

The adjacent screen will appear if Meter Cal is unsuccessful. The screen will return to the conductivity Cal Menu.

7.4.6 Cal Factor

Upon initial installation and power up, if **4-electrode** was selected for the sensor type in the **Quick Start** menus, the user enters a Cell Constant and a "Cal Factor" using the instrument keypad. The cell constant is needed to convert measured conductance to conductivity as displayed on the analyzer screen. The "Cal Factor" entry is needed increase the accuracy of the live conductivity readings, especially at low conductivity readings below 20uS/cm. Both the Cell Constant and the "Cal Factor" are printed on the tag attached to the 4-electrode sensor/cable.

The display screen for entering Cal Factor is shown. The default value is displayed in **bold type**. If necessary after initial installation and start-up, enter the "Cal Factor" as printed on the sensor tag.

```
S1: 1.234µS/cm  1.234°C
S2: 12.34pH    1.234°C
S3: 12.34µS/cm 1.234°C
SN Cal Factor
0.95000 /cm
```

7.5 CALIBRATING TEMPERATURE

7.5.1 DESCRIPTION

Most liquid analytical measurements require temperature compensation (except ORP). The Model 1057 performs temperature compensation automatically by applying internal temperature correction algorithms. Temperature correction can also be turned off. If temperature correction is off, the Model 1057 uses the manual temperature entered by the user in all temperature correction calculations.

THIS SECTION DESCRIBES HOW TO CALIBRATE TEMPERATURE IN THE MODEL 1057 ANALYZER. THE FOLLOWING CALIBRATION ROUTINE IS COVERED.

TABLE 7- 11 Temperature Calibration Routine

Measure	Sec.	Calibration function: default value	Description
Temperature	7.5.2	Calibrate	Enter a manual reference temperature for temperature compensation of the process measurement

A detailed flow diagram is provided at the end of Sec. 7 to guide you through the calibration routines.

To calibrate temperature:

1. Press the **MENU** button
2. Select **Calibrate**. Press ENTER.
3. Select **Sensor 1** or **Sensor 2** corresponding to the desired measurement. Press ENTER.
4. Select **Temperature**. Press ENTER.

```
S1: 1.234µS/cm 1.234°C
S2: 12.34pH 1.234°C
S3: 12.34µS/cm 1.234°C
SN Calibrate
+025.0°C
```

The adjacent screen will appear.

The following sub-section provides you with the initial display screen that appears for temperature calibration. Use the **flow diagram for Temp calibration** at the end of Sec. 7 to complete calibration.

```
S1: 1.234µS/cm 1.234°C
S2: 12.34pH 1.234°C
S3: 12.34µS/cm 1.234°C
SN Calibrate
Cal in progress.
Please wait.
```

7.5.2 CALIBRATION

The adjacent screen will appear during Temperature Cal.

If the sensor Temperature offset is greater than 5 °C from the default value, the following screen will appear:

You may continue by selecting Yes or suspend this operation by selecting No.

```
S1: 1.234µS/cm 1.234°C
S2: 12.34pH 1.234°C
S3: 12.34µS/cm 1.234°C
SN Temp Offset > 5°C
Continue?
No
Yes
```

If the Temp Cal is successful, the screen will return to the Cal Menu.

Note: To select automatic or manual temp compensation or to program temperature units as °C or °F, refer to Sec. 5.3 – Programming Temperature in this manual

FIGURE 7-1 Calibrate pH

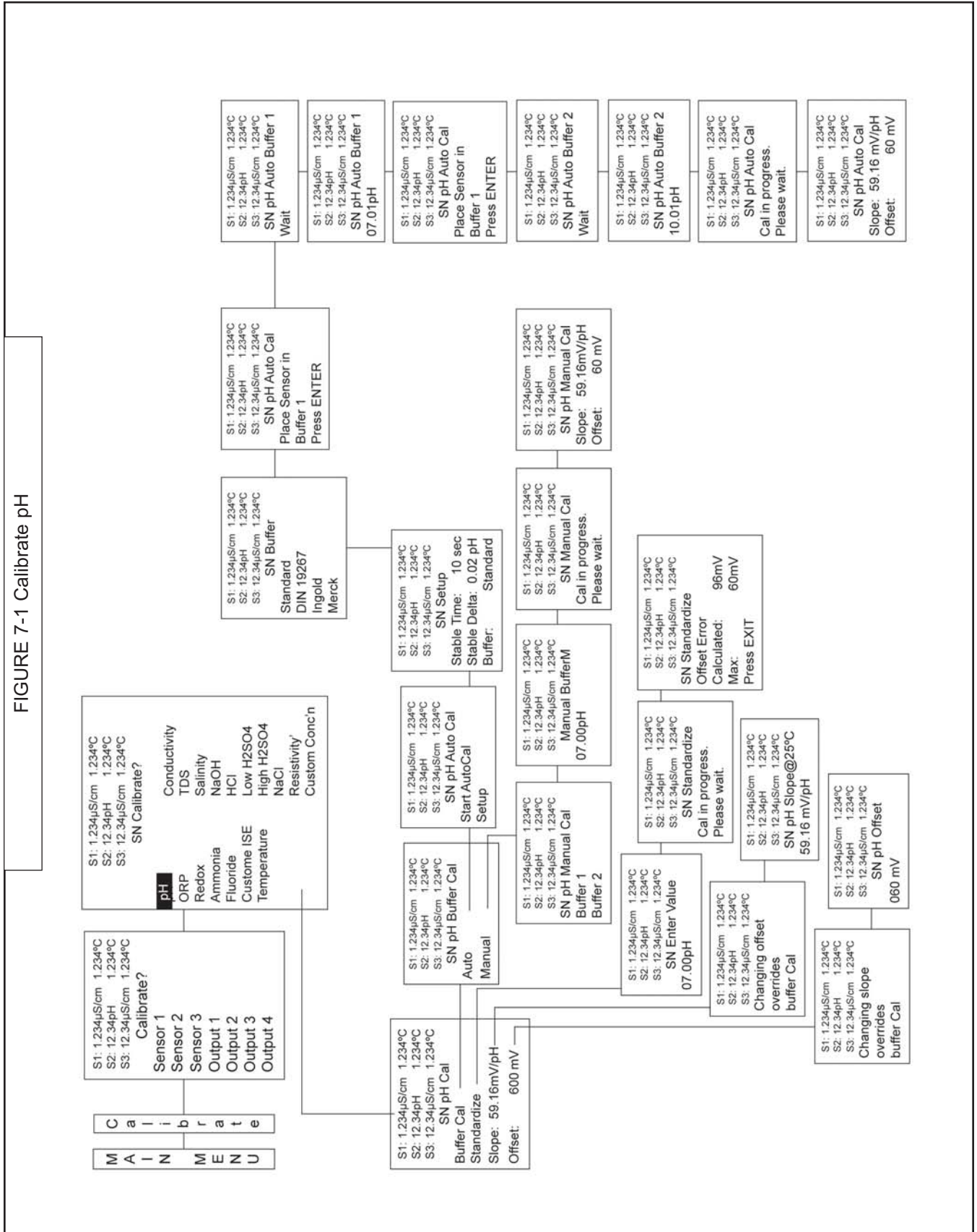

FIGURE 7-2 Calibrate ORP

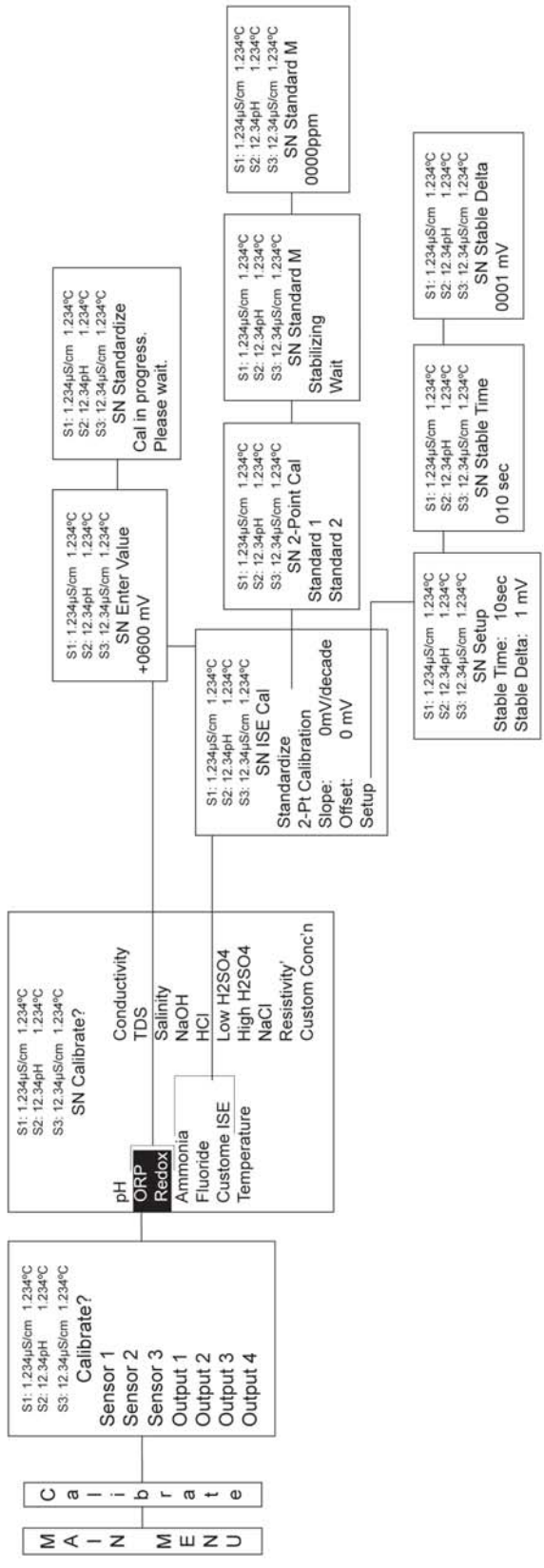

FIGURE 7-3 Calibrate Contacting Conductivity

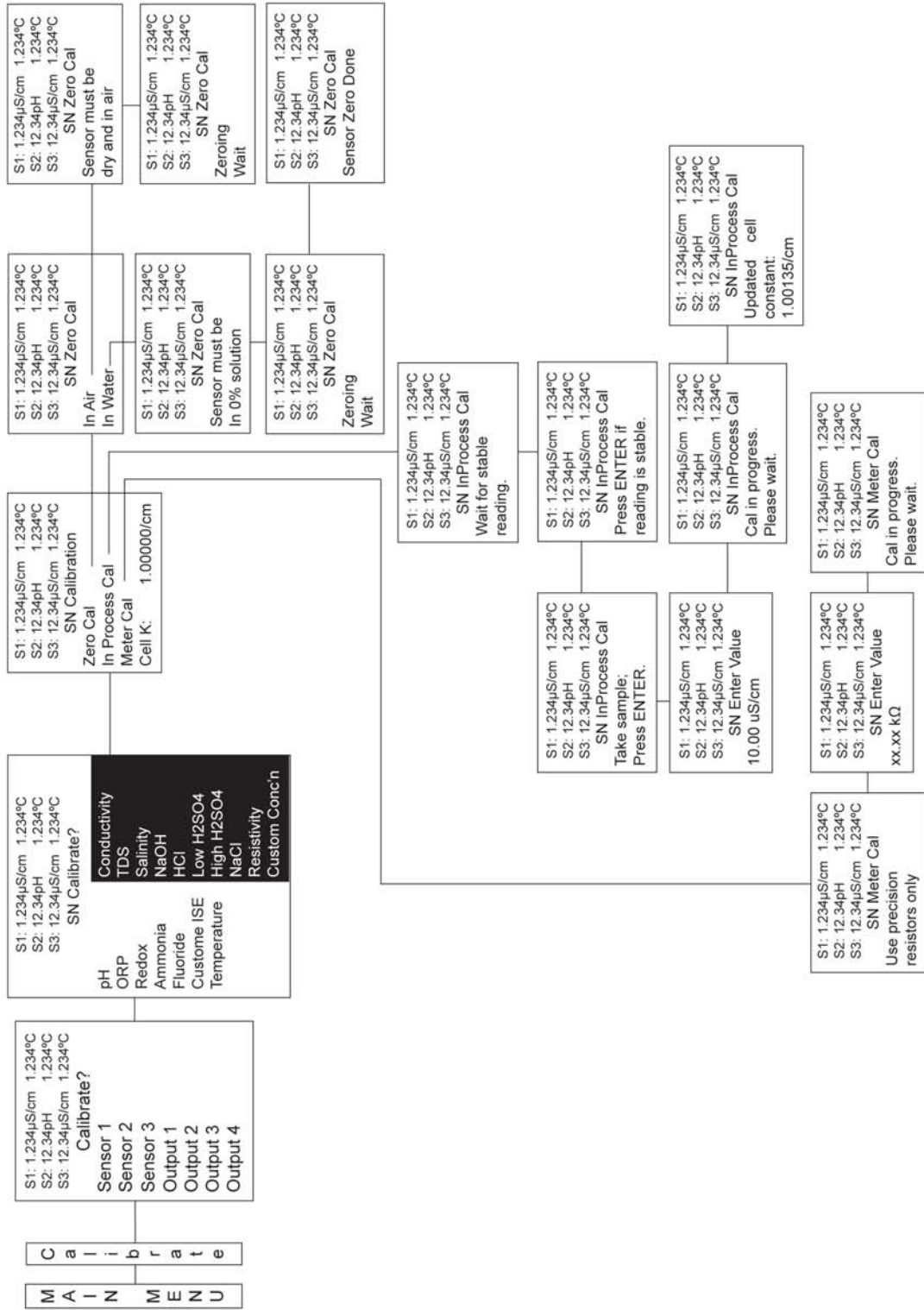
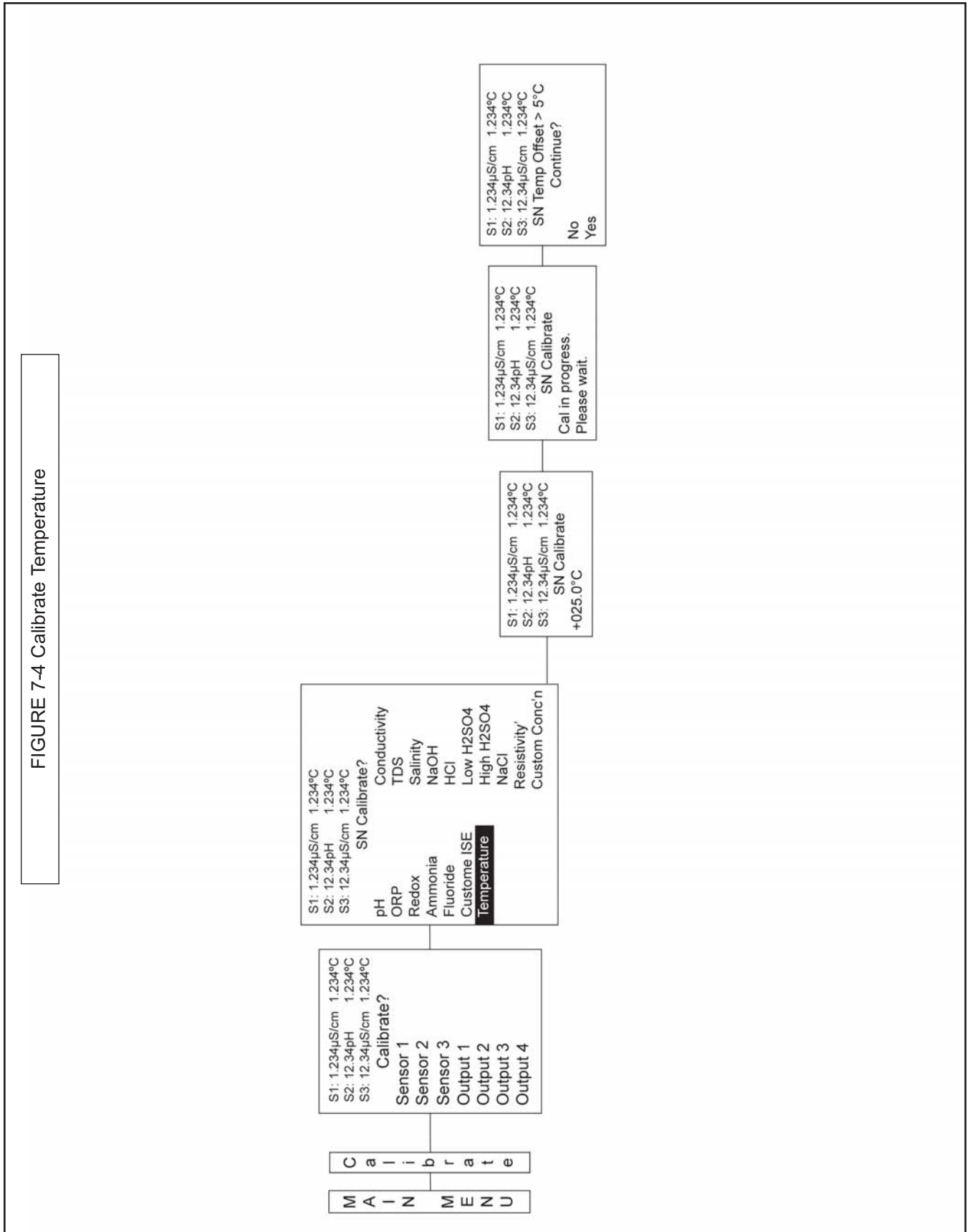

FIGURE 7-4 Calibrate Temperature



SECTION 8.0 RETURN OF MATERIAL

8.1 GENERAL

To expedite the repair and return of instruments, proper communication between the customer and the factory is important. Before returning a product for repair, call 1-949-757-8500 for a Return Materials Authorization (RMA) number.

8.2 WARRANTY REPAIR

The following is the procedure for returning instruments still under warranty:

1. Call Rosemount Analytical for authorization.
2. To verify warranty, supply the factory sales order number or the original purchase order number. In the case of individual parts or sub-assemblies, the serial number on the unit must be supplied.
3. Carefully package the materials and enclose your "Letter of Transmittal" (see Warranty). If possible, pack the materials in the same manner as they were received.
4. Send the package prepaid to:

Rosemount Analytical
Liquid Division
2400 Barranca Parkway
Irvine, CA 92606

Attn: Factory Repair

RMA No. _____

Mark the package: Returned for Repair

Model No. _____

IMPORTANT

Please see second section of "Return of Materials Request" form. Compliance with the OSHA requirements is mandatory for the safety of all personnel. MSDS forms and a certification that the instruments have been disinfected or detoxified are required.

8.3 NON-WARRANTY REPAIR

The following is the procedure for returning for repair instruments that are no longer under warranty:

1. Call Rosemount Analytical for authorization.
2. Supply the purchase order number, and make sure to provide the name and telephone number of the individual to be contacted should additional information be needed.
3. Do Steps 3 and 4 of Section 17.2.

NOTE

Consult the factory for additional information regarding service or repair.

WARRANTY

Seller warrants that the firmware will execute the programming instructions provided by Seller, and that the Goods manufactured or Services provided by Seller will be free from defects in materials or workmanship under normal use and care until the expiration of the applicable warranty period. Goods are warranted for twelve (12) months from the date of initial installation or eighteen (18) months from the date of shipment by Seller, whichever period expires first. **Consumables, such as glass electrodes, membranes, liquid junctions, electrolyte, o-rings, catalytic beads, etc., and Services are warranted for a period of 90 days from the date of shipment or provision.**

Products purchased by Seller from a third party for resale to Buyer ("Resale Products") shall carry only the warranty extended by the original manufacturer. Buyer agrees that Seller has no liability for Resale Products beyond making a reasonable commercial effort to arrange for procurement and shipping of the Resale Products.

If Buyer discovers any warranty defects and notifies Seller thereof in writing during the applicable warranty period, Seller shall, at its option, promptly correct any errors that are found by Seller in the firmware or Services, or repair or replace F.O.B. point of manufacture that portion of the Goods or firmware found by Seller to be defective, or refund the purchase price of the defective portion of the Goods/Services.

All replacements or repairs necessitated by inadequate maintenance, normal wear and usage, unsuitable power sources, unsuitable environmental conditions, accident, misuse, improper installation, modification, repair, storage or handling, or any other cause not the fault of Seller are not covered by this limited warranty, and shall be at Buyer's expense. Seller shall not be obligated to pay any costs or charges incurred by Buyer or any other party except as may be agreed upon in writing in advance by an authorized Seller representative. All costs of dismantling, reinstallation and freight and the time and expenses of Seller's personnel for site travel and diagnosis under this warranty clause shall be borne by Buyer unless accepted in writing by Seller.

Goods repaired and parts replaced during the warranty period shall be in warranty for the remainder of the original warranty period or ninety (90) days, whichever is longer. This limited warranty is the only warranty made by Seller and can be amended only in a writing signed by an authorized representative of Seller. Except as otherwise expressly provided in the Agreement, THERE ARE NO REPRESENTATIONS OR WARRANTIES OF ANY KIND, EXPRESS OR IMPLIED, AS TO MERCHANTABILITY, FITNESS FOR PARTICULAR PURPOSE, OR ANY OTHER MATTER WITH RESPECT TO ANY OF THE GOODS OR SERVICES.

RETURN OF MATERIAL

Material returned for repair, whether in or out of warranty, should be shipped prepaid to:

**Emerson Process Management
Liquid Division
2400 Barranca Parkway
Irvine, CA 92606**

The shipping container should be marked:

Return for Repair

Model _____

The returned material should be accompanied by a letter of transmittal which should include the following information (make a copy of the "Return of Materials Request" found on the last page of the Manual and provide the following thereon):

1. Location type of service, and length of time of service of the device.
2. Description of the faulty operation of the device and the circumstances of the failure.
3. Name and telephone number of the person to contact if there are questions about the returned material.
4. Statement as to whether warranty or non-warranty service is requested.
5. Complete shipping instructions for return of the material.

Adherence to these procedures will expedite handling of the returned material and will prevent unnecessary additional charges for inspection and testing to determine the problem with the device.

If the material is returned for out-of-warranty repairs, a purchase order for repairs should be enclosed.

ORDERING INFORMATION

The Model 1057 multi-parameter analyzer supports up to three sensor inputs of pH/ORP and contacting conductivity measurements in any combination thus reducing the cost per loop and saving panel space. All configurations of the analyzer include four 4-20mA current outputs and four fully programmable alarm relays with interval timers. The instrument supports most industrial, commercial, and municipal applications and is ideal for OEMs, systems integrators and customers requiring multiple inputs and outputs. All Model 1057 units also include electrically isolated inputs, 7 local languages, removable connectors for easy wiring, 4 solid plugs for closure of openings, and panel mount hardware.

Model 1057 Three-Input Intelligent Analyzer	
CODE	Power
02	24 VDC with four alarm relays
03	84-265 VAC switching, 50/60 Hz with four alarm relays

CODE	MEASUREMENT 1
20	Contacting Conductivity
22	pH/ORP/ISE

CODE	MEASUREMENT 2
30	Contacting Conductivity
32	pH/ORP/ISE
38	None (not available if -40 or -42 are selected)

CODE	MEASUREMENT 3
40	Contacting Conductivity
42	pH/ORP/ISE
48	None

ACCESSORIES	
PART #	DESCRIPTION
23554-00	Cable Gland Kit - Qty 5 per pack
23820-00	2" Pipe Mounting Bracket includes U-bolts, mounting bracket, nuts, washers, and screws (complete). Also accommodates wall / surface mounting.
23820-01	2" Pipe Mounting Bracket, Stainless Steel
9240048-00	S.S. Tag (specify marking)



*The right people,
the right answers,
right now.*

**ROSEMOUNT ANALYTICAL
CUSTOMER SUPPORT CENTER
1-800-854-8257**



ON-LINE ORDERING NOW AVAILABLE ON OUR WEB SITE
<http://www.raihome.com>

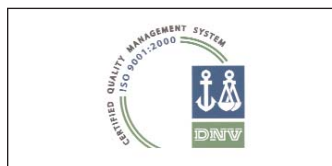

Credit Cards for U.S. Purchases Only.



Emerson Process Management

Rosemount Analytical Inc.

2400 Barranca Parkway
Irvine, CA 92606 USA
Tel: (949) 757-8500
Fax: (949) 474-7250

<http://www.raihome.com>

