

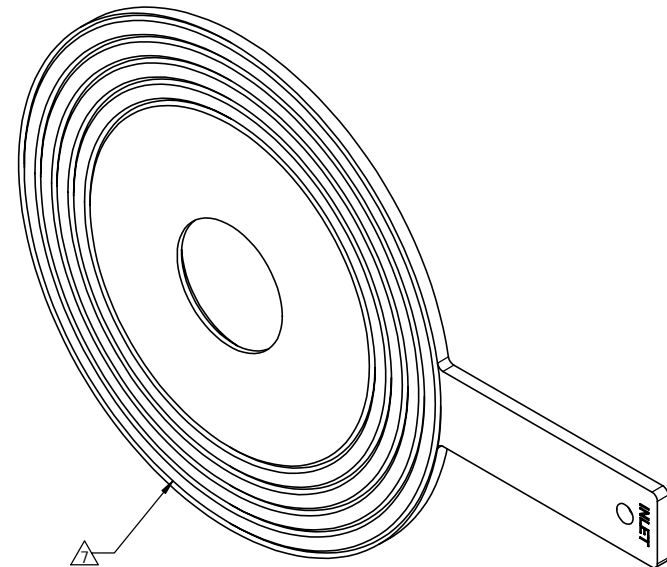

REVISIONS				
REV	DESCRIPTION	CHG.NO.	APP'D	DATE
AA	NEW RELEASE	EC004683	MH	1/14/04

NOTES:

- ROSEMOUNT INC. CERTIFIES THIS DRAWING IS IN ACCORDANCE WITH ROSEMOUNT ENGINEERING SPECIFICATIONS AND ACCURATELY REPRESENTS THE EQUIPMENT FURNISHED.
 - ORIFICE PLATE ORIENTATION SHOWN FOR DETAIL ONLY. FOR ACTUAL RECOMMENDED LOCATION AND ORIENTATION REFER TO INSTALLATION INSTRUCTION MANUAL 00809-0100-4792 AND PAGE 11 OF THIS DOCUMENT.
 - FOR MODEL SELECTIONS, MATERIALS, AND OPTIONS, REFER TO ROSEMOUNT PRODUCT DATA SHEET 00813-0100-4792.
 - MODEL 1495 MAXIMUM TEMPERATURE IS 850°F (OBSERVE GASKET MATERIAL TEMPERATURE LIMITATIONS).
 - ORIFICE FLANGES, STUDS, NUTS AND GASKETS ARE NOT INCLUDED WITH MODEL 1495.
 - SPIRAL FINISH PLATES ARE AVAILABLE ONLY TO 12" LINE SIZE, AND ARE NOT AVAILABLE IN DIN SIZES.
- △ SPIRAL FINISH 125-250 MICROINCH RMS, 45-55 GROOVES PER INCH



*UNLESS OTHERWISE SPECIFIED DIMENSIONS IN INCHES (MM)		TYPE I		ROSEMOUNT® BOULDER, COLORADO	
*ALL DIMENSIONS ARE NOMINAL AND ARE FOR REFERENCE ONLY		DR.	DMK	11/17/03	TITLE
		APPROVAL		DIMENSIONAL DRAWING FOR MODEL 1495 PADDLE STYLE SPIRAL FINISH ORIFICE PLATE PRIMARY	
		DRAWING	K. GREEN	12/20/03	SIZE
		TAGGING			A
SPECIALS				SCALE: NONE	01495-1002
				SHEET	1 OF 12

LINE SIZE	'A' DIMENSION (PADDLE TYPE PLATE DIAMETER)					
	150#	300#	600#	900#	1500#	2500#
2" (DN 50)	4.13	4.38		5.63		5.75
2-1/2" (DN 65)	4.88	5.13		6.50		6.63
3" (DN 80)	5.38	5.88		6.63	6.88	7.75
3-1/2"	6.38	6.50	6.38	N/A		
4" (DN 100)	6.88	7.13	7.63	8.13	8.25	9.25
6" (DN 150)	8.75	9.88	10.50	11.38	11.13	12.50
8" (DN 200)	11.00	12.13	12.63	14.13	13.88	15.25
10" (DN 250)	13.38	14.25	15.75	17.13	17.13	18.75
12" (DN 300)	16.13	16.63	18.00	19.63	20.50	21.63

LINE SIZE	'B' (HANDLE LENGTH)	'C' (HANDLE WIDTH)	'D' (DEFAULT THICKNESS)
2" (DN 50)	4.00	1.00	0.13
2-1/2" (DN 65)	4.00	1.25	0.13
3" (DN 80)	4.00	1.25	0.13
3-1/2"	4.00	1.25	0.13
4" (DN 100)	4.00	1.25	0.13
6" (DN 150)	5.00	1.50	0.13
8" (DN 200)	5.00	1.50	0.25
10" (DN 250)	6.00	1.50	0.25
12" (DN 300)	6.00	1.50	0.38

ROSEMOUNT®		
BOULDER, COLORADO		
SIZE A	FSCM.NO.	DRAWING NO. 01495-1002
SCALE: NONE WT.		SHEET 2 OF 12

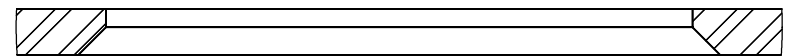
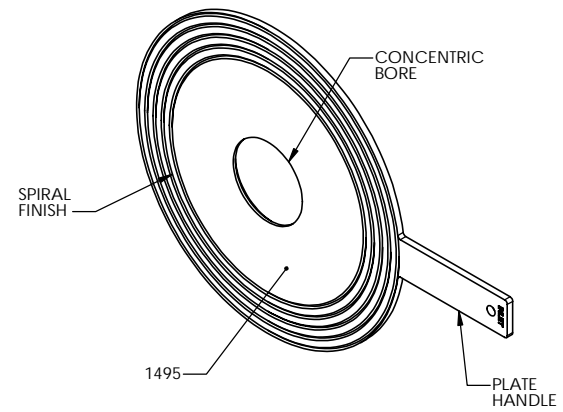
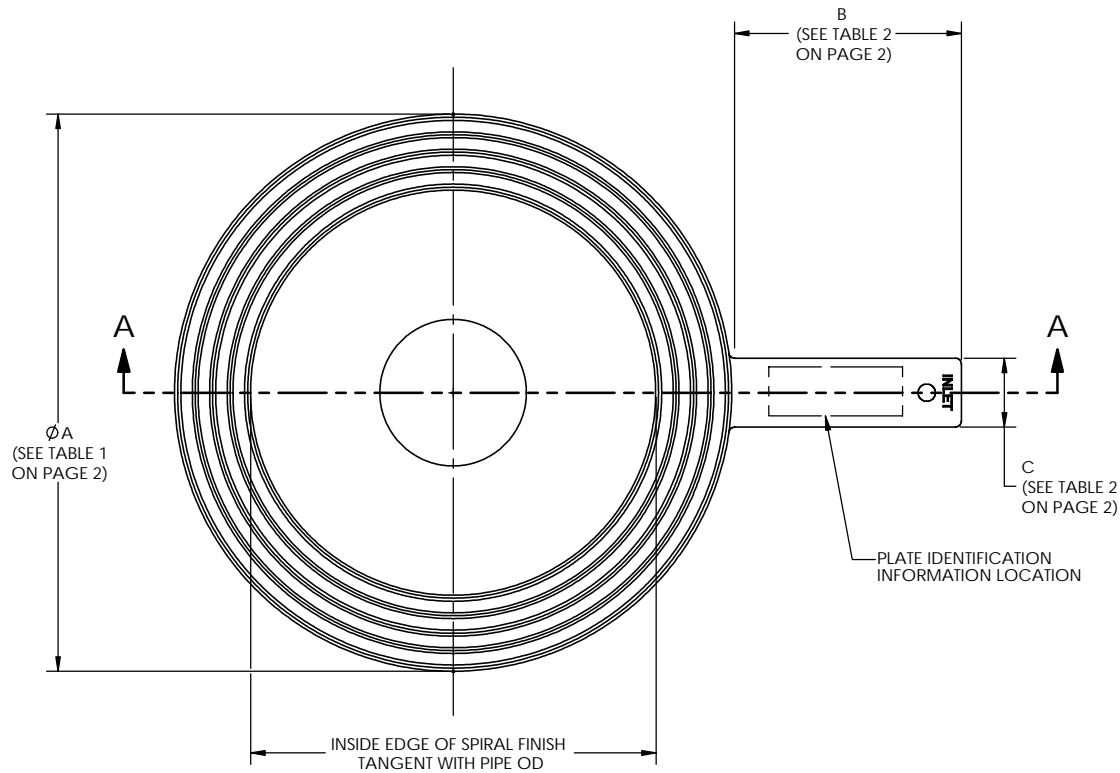

DETAIL B
SCALE 2 : 1

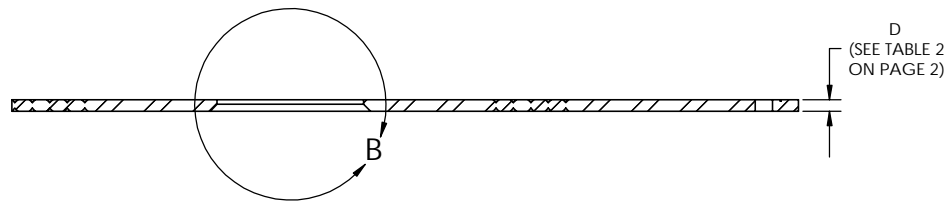

SECTION A-A

CONCENTRIC BORE

ROSEMOUNT®			
BOULDER, COLORADO			
SIZE A	FSCM.NO.	DRAWING NO.	01495-1002
SCALE: NONE WT.			SHEET 3 OF 12

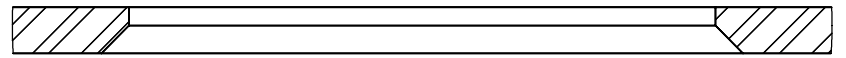
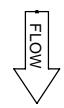
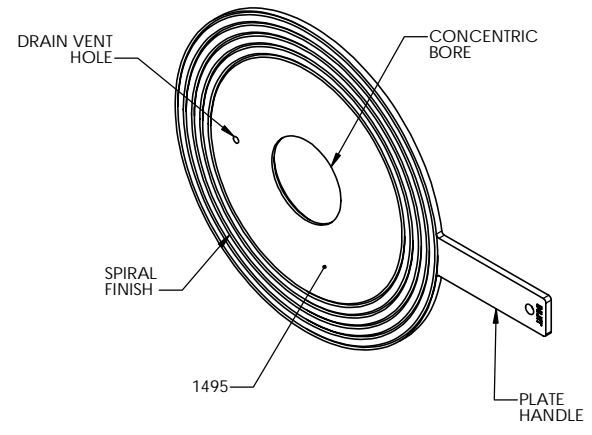
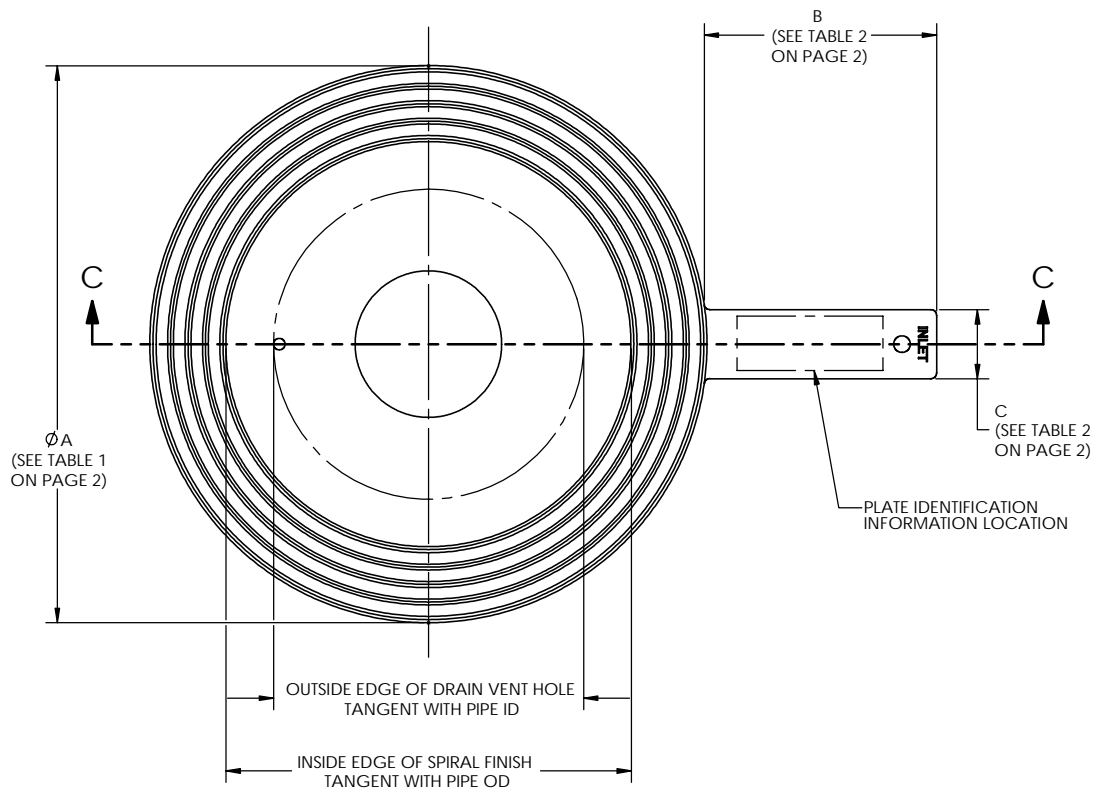

DETAIL D
SCALE 2 : 1

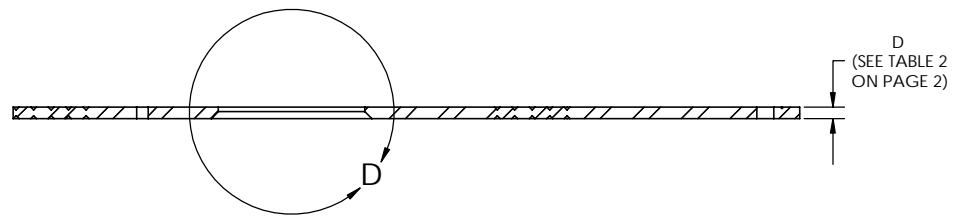

SECTION C-C

**CONCENTRIC BORE
WITH DRAIN VENT HOLE**

ROSEMOUNT®		
BOULDER, COLORADO		
SIZE A	FSCM.NO.	DRAWING NO. 01495-1002
SCALE: NONE WT.		SHEET 4 OF 12

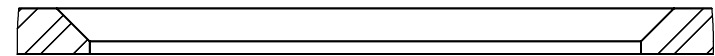
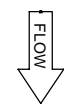
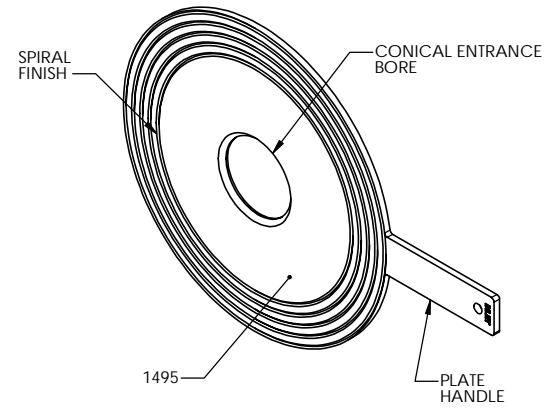
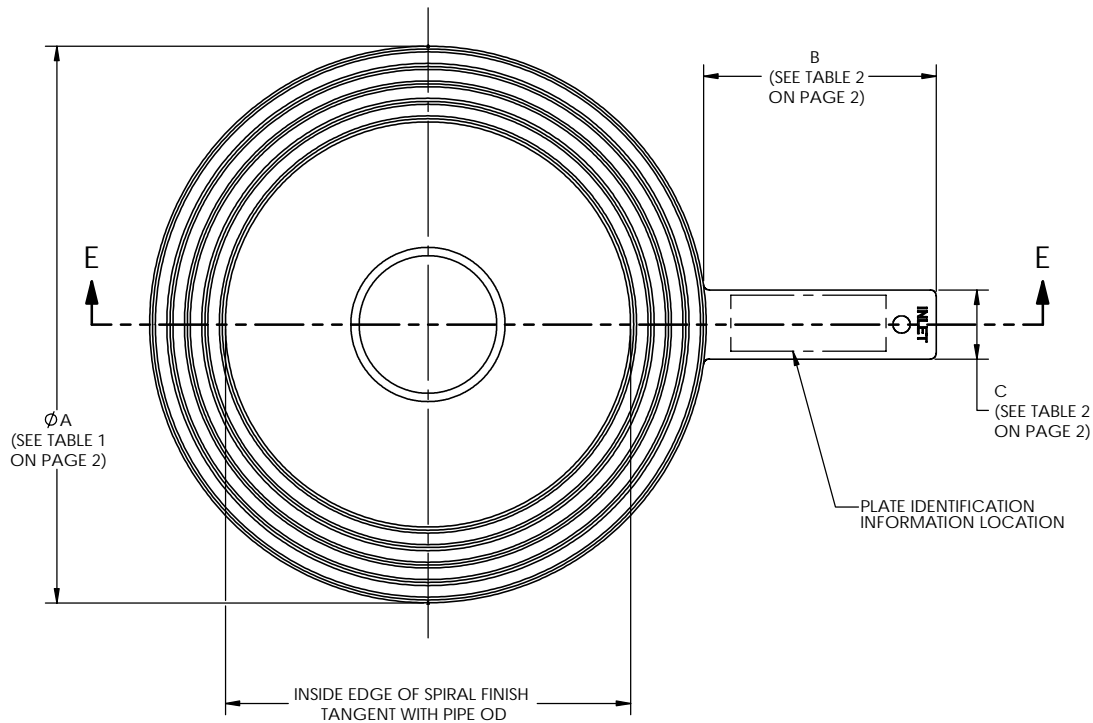

DETAIL F
 SCALE 2 : 1

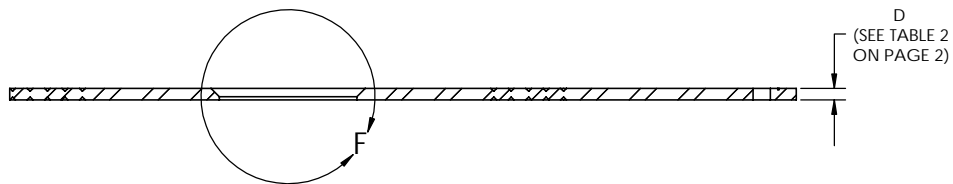

CONICAL ENTRANCE BORE

ROSEMOUNT®		
<small>BOULDER, COLORADO</small>		
SIZE A	FSCM.NO.	DRAWING NO. 01495-1002
SCALE: NONE WT.		SHEET 5 OF 12

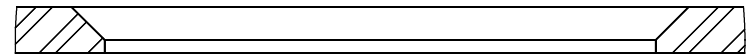
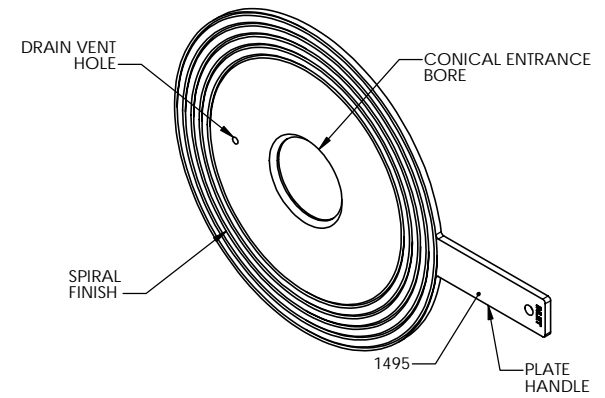
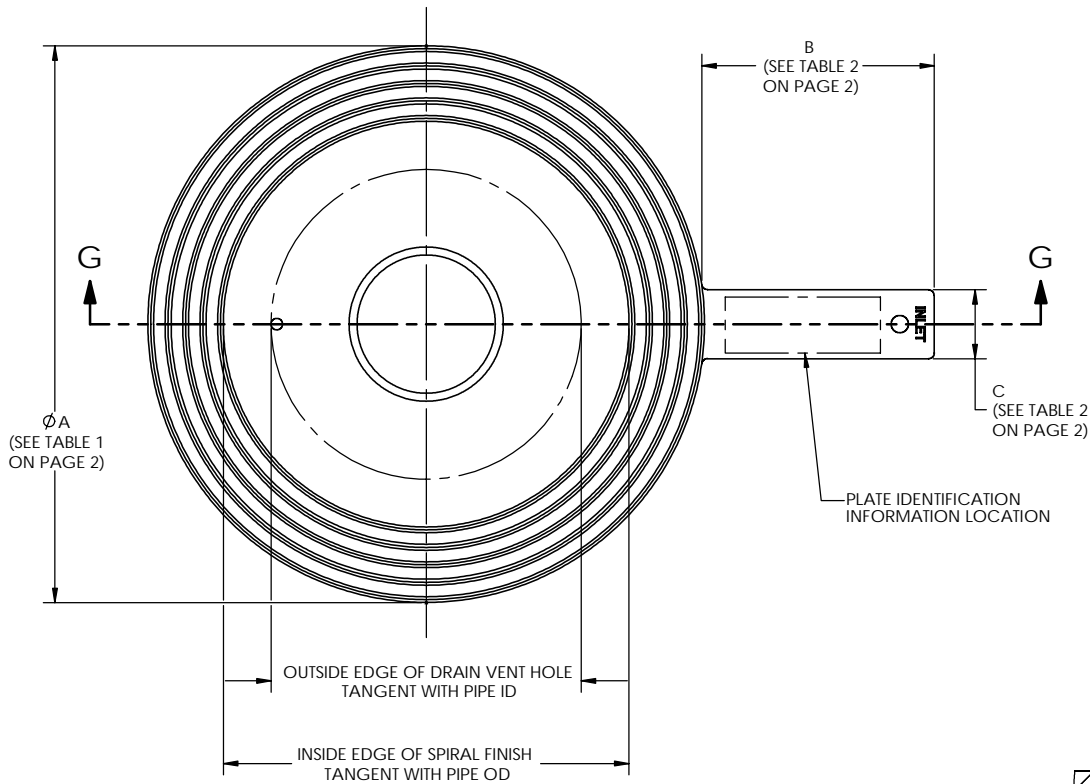

DETAIL H
 SCALE 2 : 1

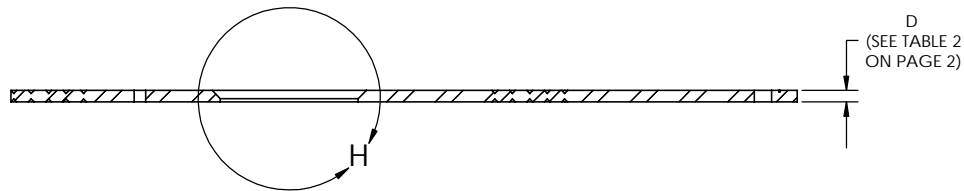

SECTION G-G

**CONICAL ENTRANCE BORE
 WITH DRAIN VENT HOLE**

ROSEMOUNT®

BOULDER, COLORADO

SIZE A	FSCM.NO.	DRAWING NO. 01495-1002
-----------	----------	---------------------------

SCALE: NONE WT.	SHEET 6 OF 12
-------------------	---------------

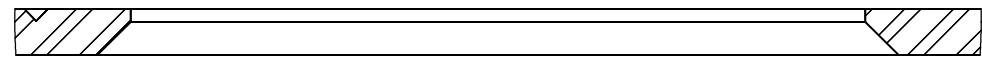
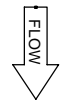
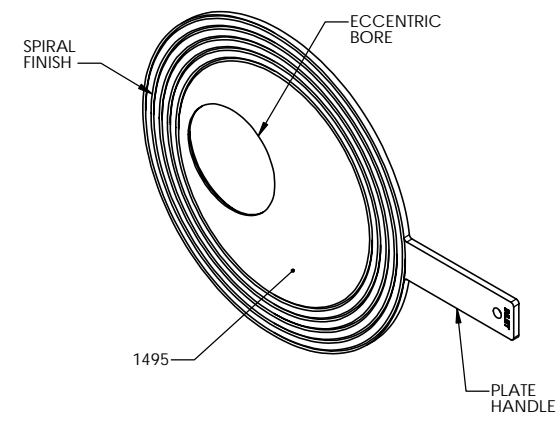
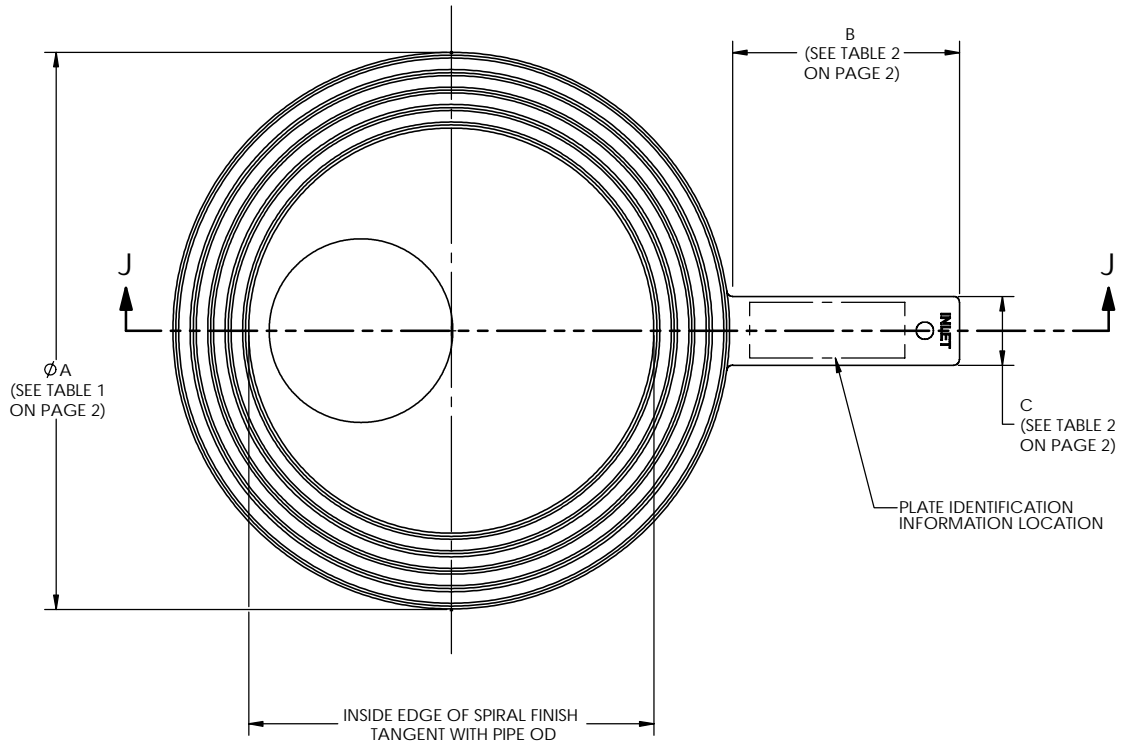

DETAIL K
 SCALE 2 : 1

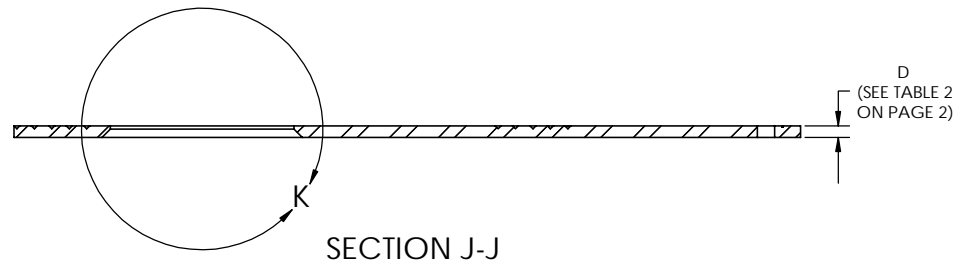

ECCENTRIC BORE

ROSEMOUNT®			
<small>BOULDER, COLORADO</small>			
SIZE A	FSCM.NO.	DRAWING NO.	01495-1002
<small>SCALE: NONE WT.</small>			<small>SHEET 7 OF 12</small>

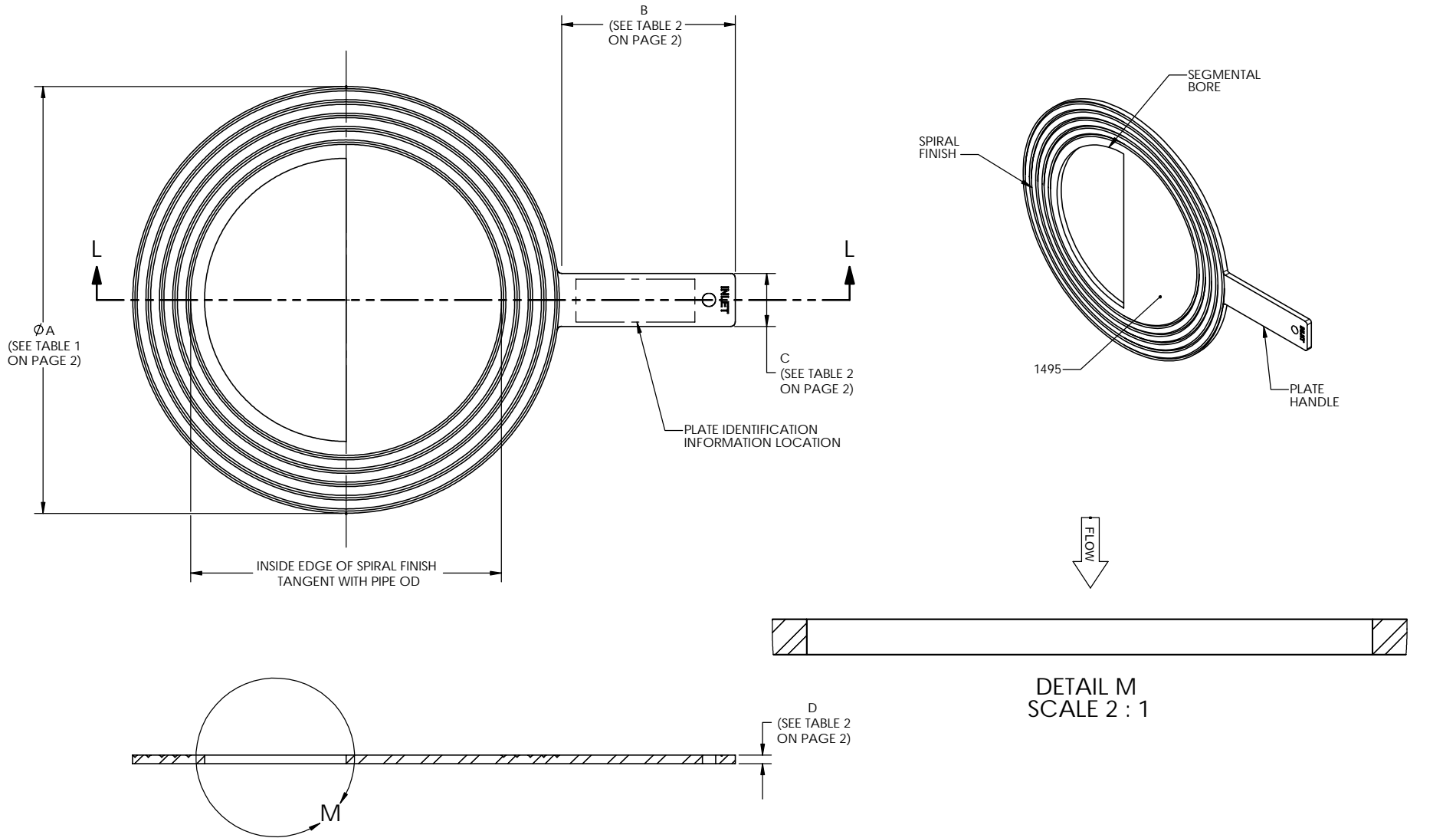

SECTION L-L

DETAIL M
SCALE 2 : 1

SEGMENTAL BORE

ROSEMOUNT®		
<small>BOULDER, COLORADO</small>		
SIZE A	FSCM.NO.	DRAWING NO. 01495-1002
SCALE: NONE WT.		SHEET 8 OF 12

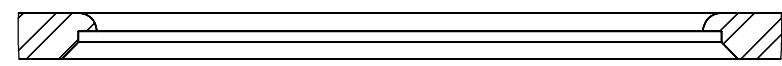
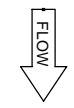
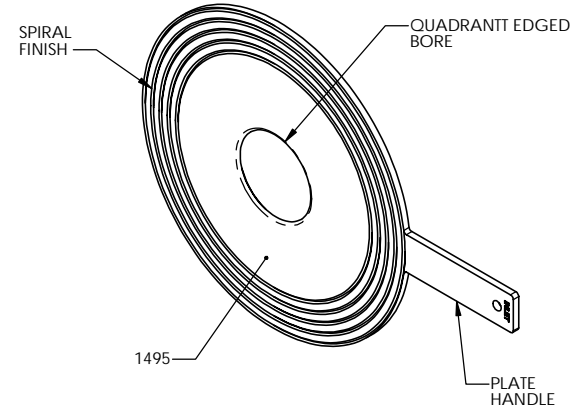
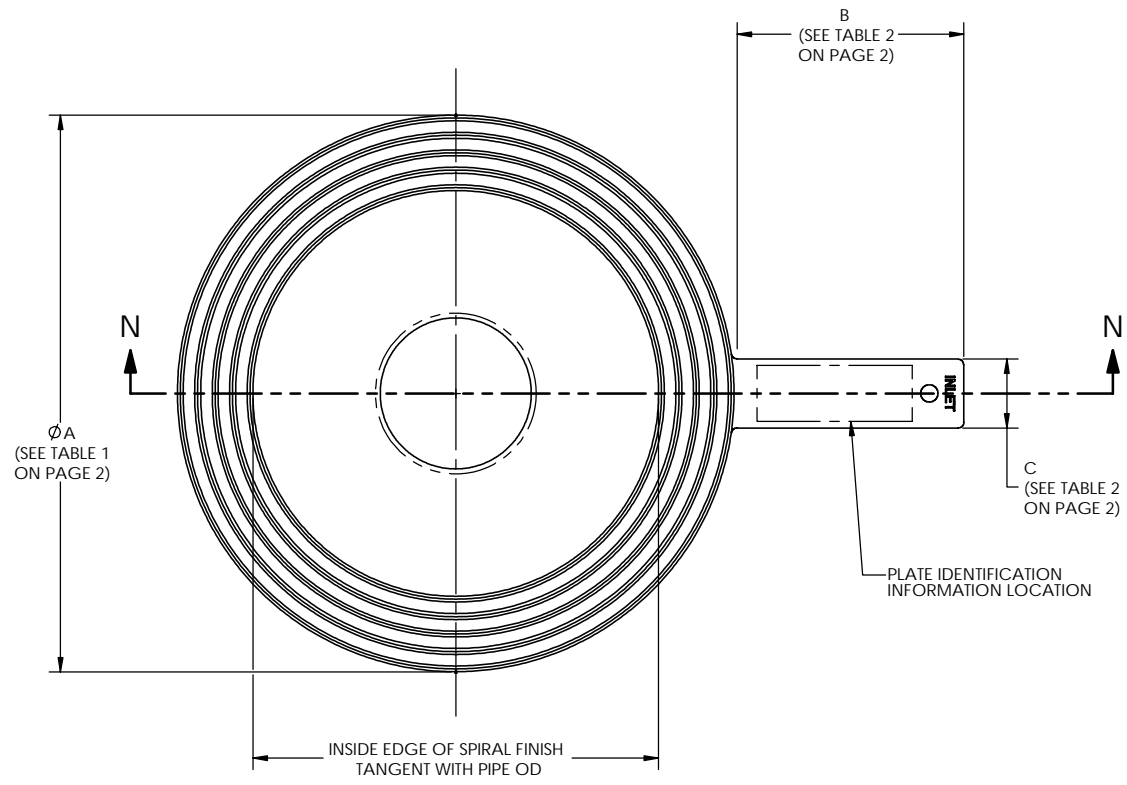

DETAIL P
 SCALE 2 : 1

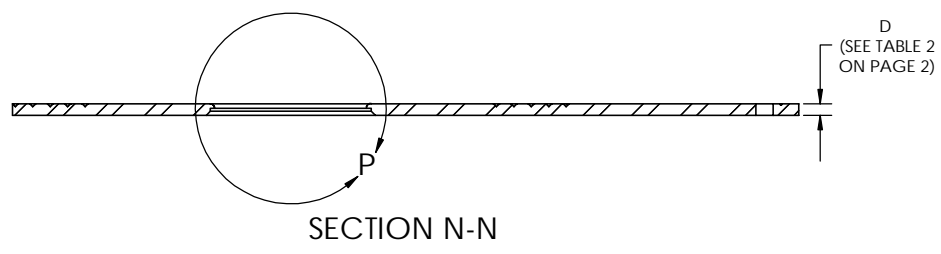

QUADRANT EDGED BORE

ROSEMOUNT®			
<small>BOULDER, COLORADO</small>			
SIZE A	FSCM.NO.	DRAWING NO.	01495-1002
SCALE: NONE WT.			SHEET 9 OF 12

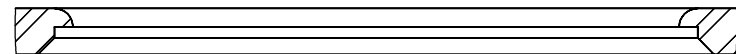
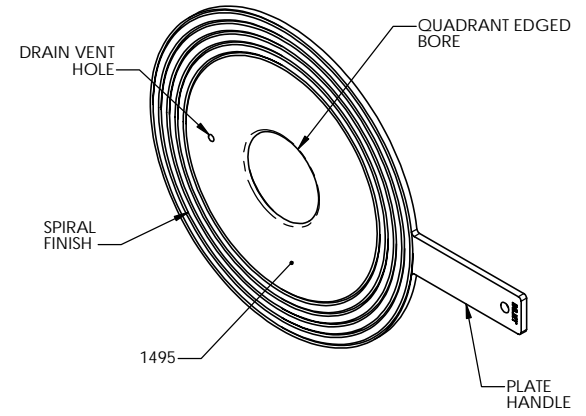
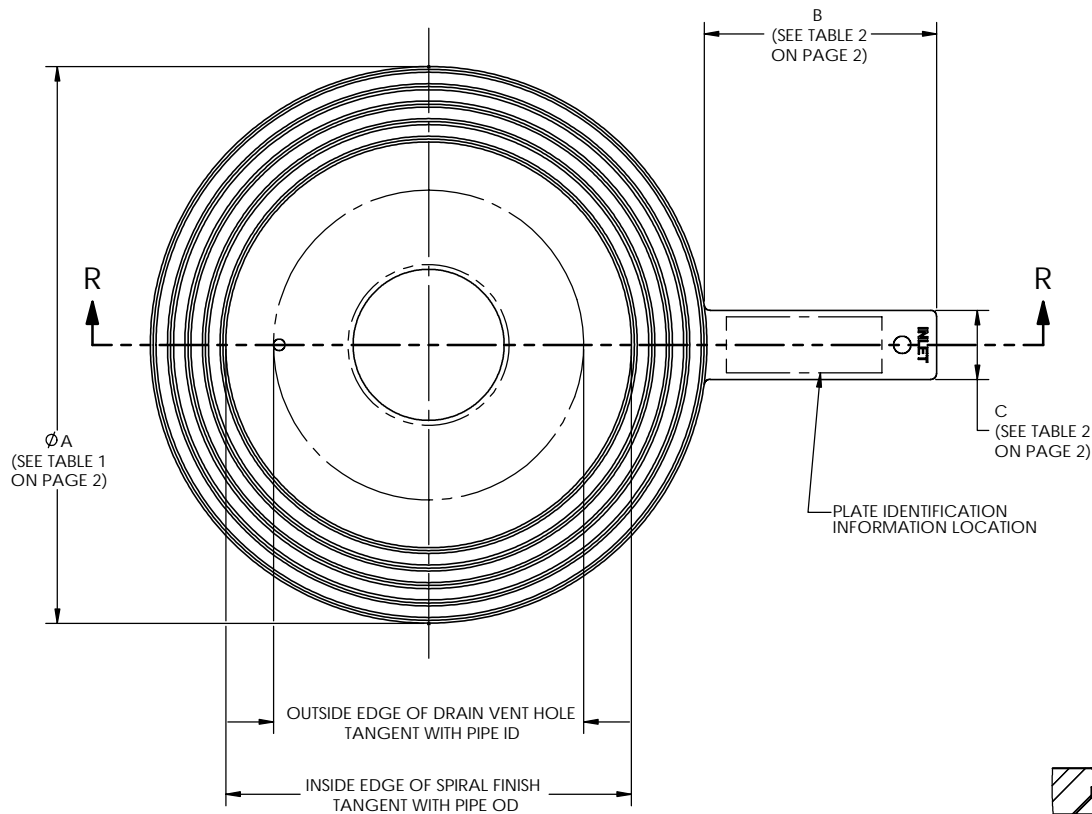

DETAIL T
SCALE 2 : 1

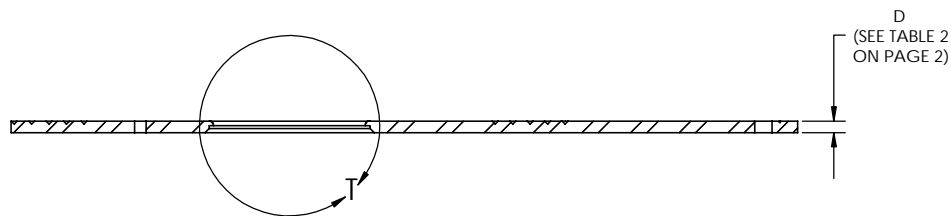

SECTION R-R

**QUADRANT EDGED BORE
WITH DRAIN VENT HOLE**

ROSEMOUNT®

BOULDER, COLORADO

SIZE A	FSCM.NO.	DRAWING NO. 01495-1002
-----------	----------	---------------------------

SCALE: NONE WT.	SHEET 10 OF 12
-------------------	----------------

HORIZONTAL / VERTICAL GAS, LIQUID AND STEAM
(RECOMMENDED INSTALLATION)

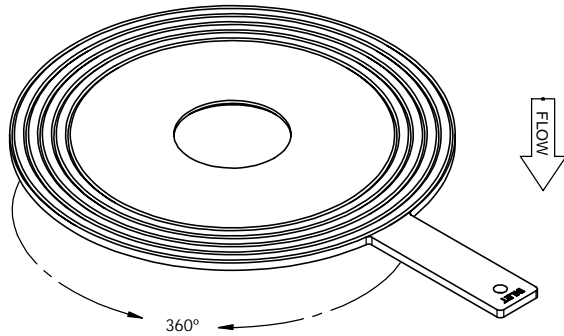

VERTICAL WITH DRAIN VENT HOLE
GAS, LIQUID AND STEAM
(RECOMMENDED INSTALLATION)

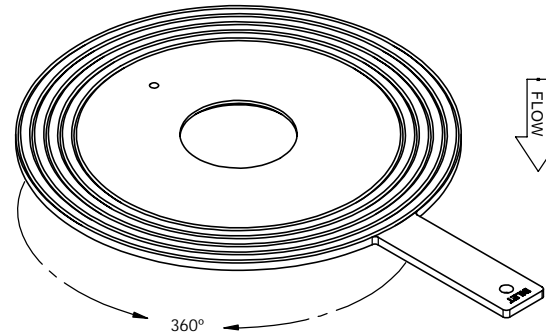

HORIZONTAL WITH DRAIN VENT HOLE
GAS AND STEAM
(RECOMMENDED INSTALLATION)

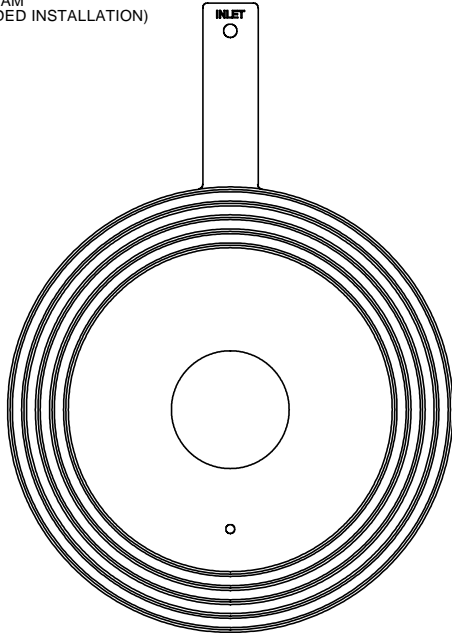

HORIZONTAL WITH DRAIN VENT HOLE
LIQUID
(RECOMMENDED INSTALLATION)

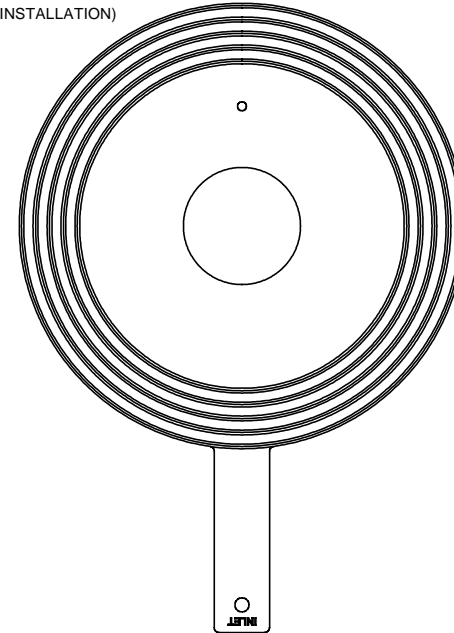

ORIENTATION OPTION

ROSEMOUNT®

BOULDER, COLORADO

SIZE A	FSCM.NO.	DRAWING NO. 01495-1002
-----------	----------	----------------------------------

SCALE: NONE WT.	SHEET 11 OF 12
-------------------	----------------

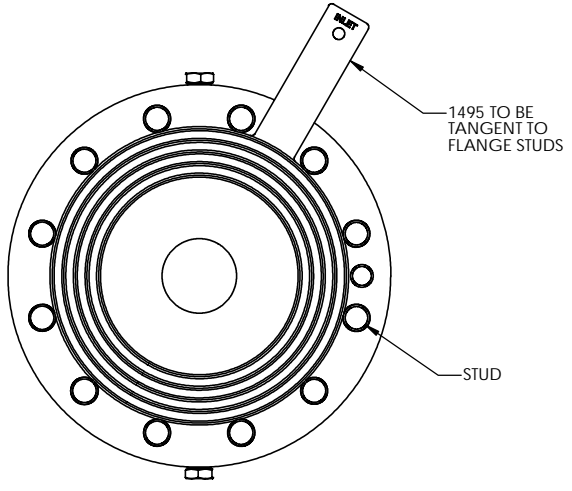

DETAIL U

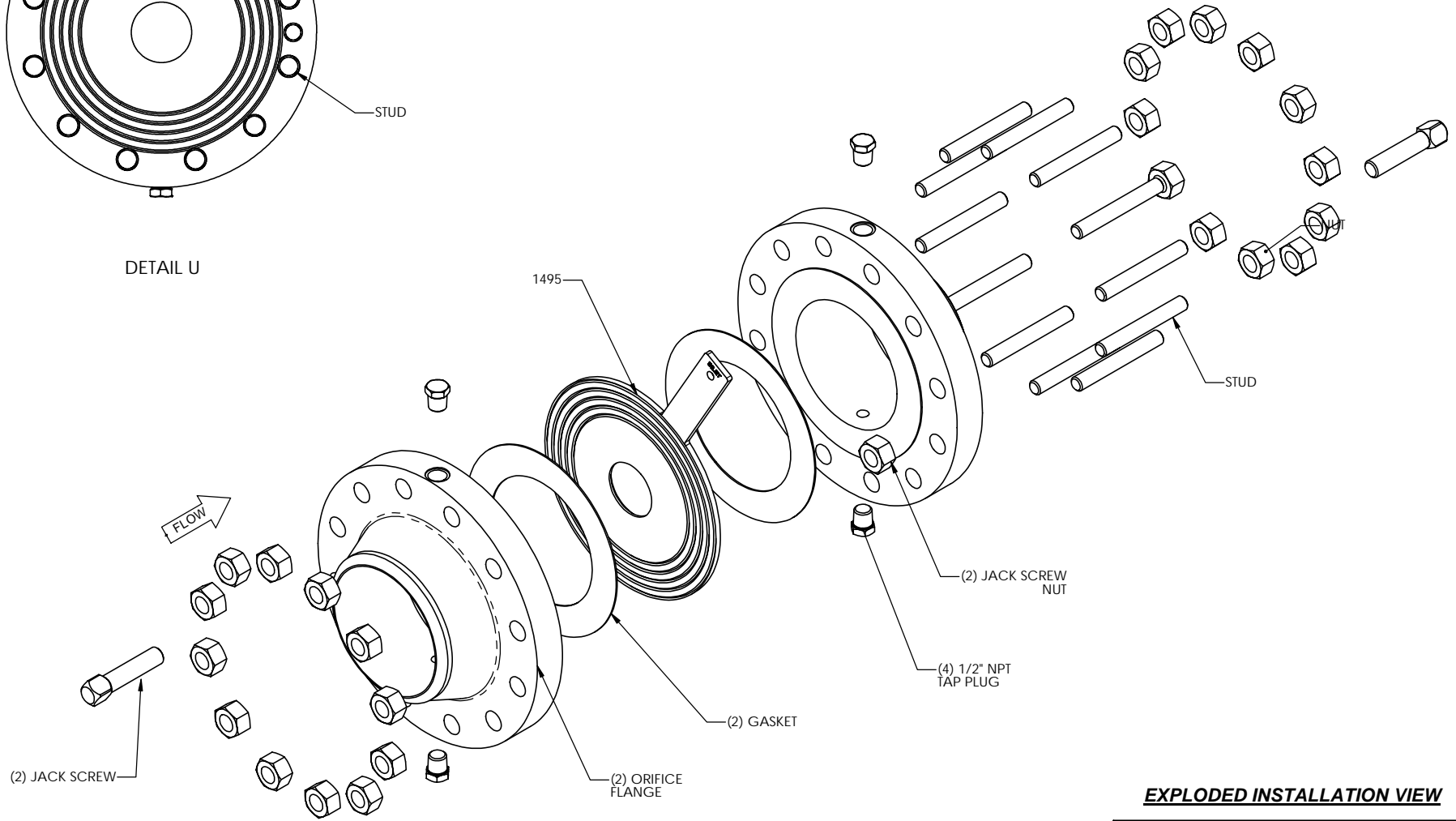

EXPLODED INSTALLATION VIEW

ROSEMOUNT®
BOULDER, COLORADO

SIZE A	FSCM.NO.	DRAWING NO. 01495-1002
SCALE: NONE WT.		SHEET 12 OF 12