

REVISIONS				
REV	DESCRIPTION	CHG.NO.	APP'D	DATE
AA	NEW RELEASE	EC004733	DRV	1/16/04

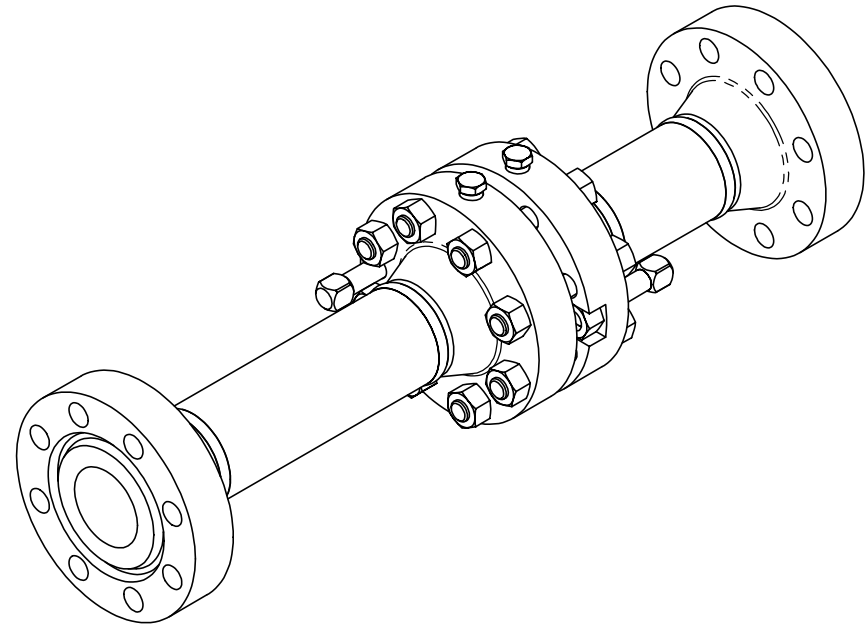

NOTES:

- ROSEMOUNT INC. CERTIFIES THIS DRAWING IS IN ACCORDANCE WITH ROSEMOUNT ENGINEERING SPECIFICATIONS AND ACCURATELY REPRESENTS THE EQUIPMENT FURNISHED.
- ORIFICE FLANGE UNIONS MEET THE REQUIREMENTS OR ANSI B16.36.
- FOR MODEL SELECTIONS, MATERIALS, AND OPTIONS, REFER TO ROSEMOUNT PRODUCT DATA SHEET 00813-0100-4792.
- MODEL 1497 MAXIMUM TEMPERATURE IS 850°F. MAXIMUM OPERATING TEMPERATURE MAY BE REDUCED DEPENDING ON MATERIAL AND GASKET SELECTIONS. REFER TO ROSEMOUNT PRODUCT DATA SHEET 00813-0100-4792 FOR DETAILS.
- MODEL 1497 INCLUDES FLANGE UNIONS, STUDS, NUTS, JACK SCREWS, AND PLUGS (PLUGS ARE NOT SUPPLIED WITH SOCKET TAP FLANGES).
- LENGTHS IN TABLE 1 DO NOT INCLUDE ORIFICE PLATE OR PLATE HOLDER. ACTUAL LENGTHS MAY VARY DEPENDING ON ACTUAL PLATE THICKNESS.
- RING JOINT PLATE HOLDER MUST BE ORDERED WITH THE 1495 ORIFICE PLATE ASSEMBLY.

*UNLESS OTHERWISE SPECIFIED DIMENSIONS IN INCHES (MM)		TYPE I		ROSEMOUNT® BOULDER, COLORADO	
*ALL DIMENSIONS ARE NOMINAL AND ARE FOR REFERENCE ONLY		DR. DMK	12/17/03	TITLE DIMENSIONAL DRAWING FOR MODEL 1497 RING JOINT, WELD NECK ORIFICE METER SECTION	
		APPROVAL		SIZE A	DRAWING NO. 01497-1002
		DRAWING K. GREEN	12/19/03		
		TAGGING			
		SPECIALS		SCALE: NONE	SHEET 1 OF 11

TABLE 1

LINE SIZE	UPSTREAM LENGTH (USL)	DOWNSTREAM LENGTH (DSL)	
		W/O TEMP TAP	W/ TEMP TAP
2"	21.0	11.0	17.0
2-1/2"	26.0	12.0	21.0
3"	32.0	16.0	24.0
4"	41.0	21.0	33.0
6"	62.0	30.0	48.0
8"	81.0	40.0	64.0
10"	101.0	51.0	82.0
12"	120.0	60.0	96.0
14"	134.0	66.0	106.0
16"	153.0	77.0	123.0
18"	173.0	87.0	138.0
20"	194.0	96.0	154.0
24"	230.0	115.0	171.0

TABLE 2

LINE SIZE	FLANGE OUTSIDE DIAMETER			
	600#	900#	1500#	2500#
2"	6.50	8.50	8.50	9.25
2-1/2"	7.50	9.62	9.62	10.50
3"	8.25	9.50	10.50	12.00
4"	10.75	11.50	12.25	14.00
6"	14.00	15.00	15.50	19.00
8"	16.50	18.50	19.00	21.75
10"	20.00	21.50	23.00	26.50
12"	22.00	24.00	26.50	30.00
14"	23.75	25.25	29.50	
16"	27.00	27.75	32.50	
18"	29.25	31.00	36.00	
20"	32.00	33.75	38.75	
24"	37.00	41.00	46.00	

TABLE 3

TEMP. TAP SIZE	FLANGED TEMPERATURE TAP HEIGHT (TTH)		
	600#	900/1500#	2500#
1"	3.88	4.32	5.38
1-1/2"	4.44	4.94	6.76
2"	4.75	5.88	7.56

ROSEMOUNT®

BOULDER, COLORADO

SIZE A	FSCM.NO.	DRAWING NO. 01497-1002
-----------	----------	----------------------------------

SCALE: NONE WT.	SHEET 2 OF 11
-------------------	---------------

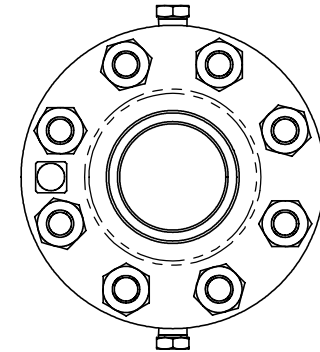
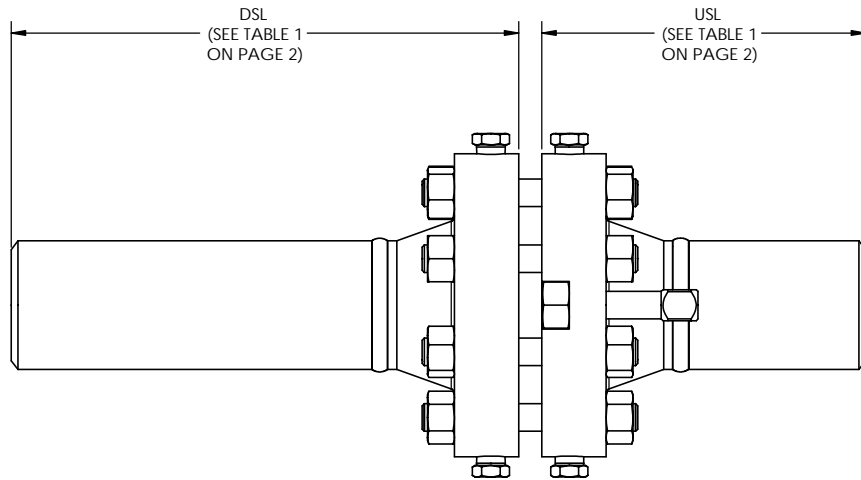
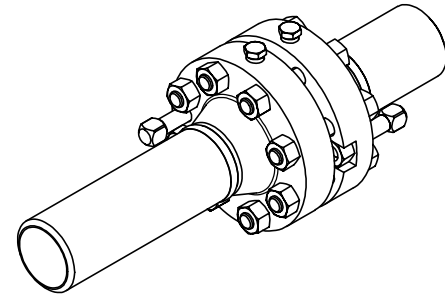
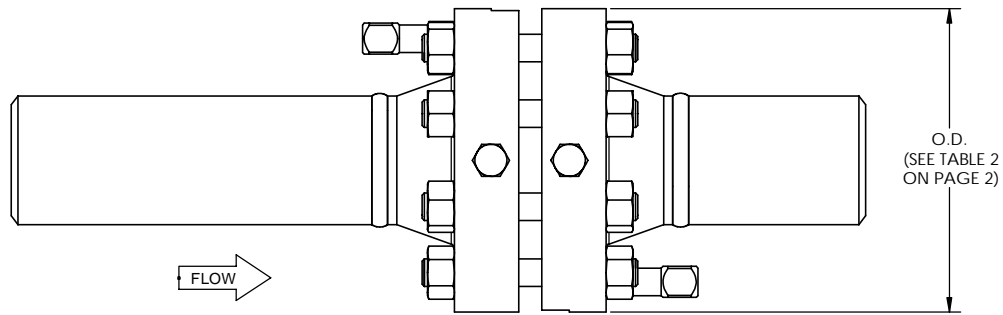

**ORIFICE METER SECTION
WITH BEVELLED ENDS**

ROSEMOUNT®

BOULDER, COLORADO

SIZE A	FSCM.NO.	DRAWING NO. 01497-1002
-----------	----------	----------------------------------

SCALE: NONE WT.	SHEET 3 OF 11
-------------------	---------------

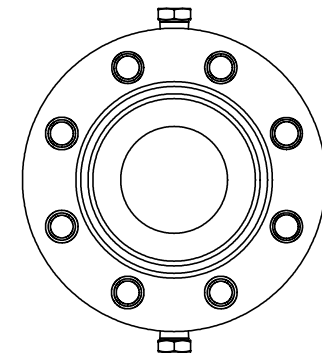
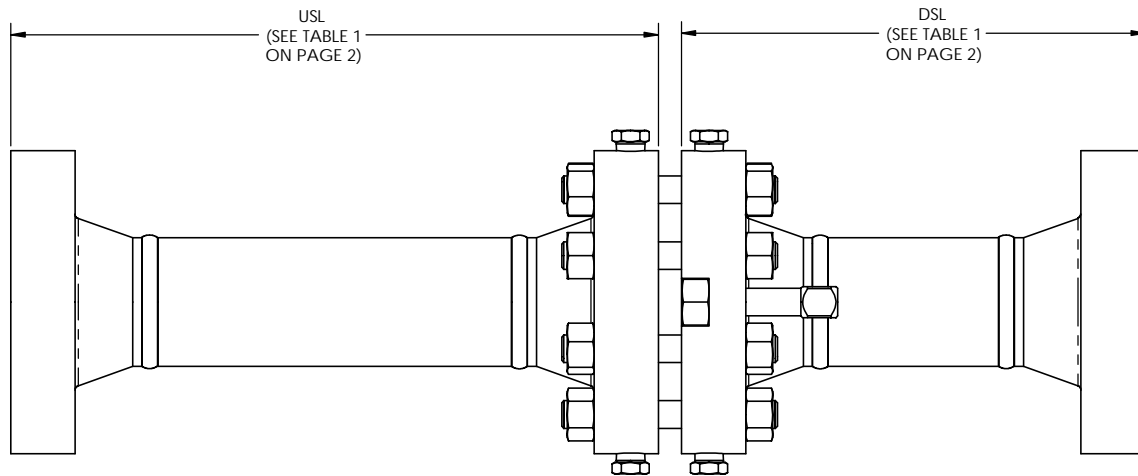
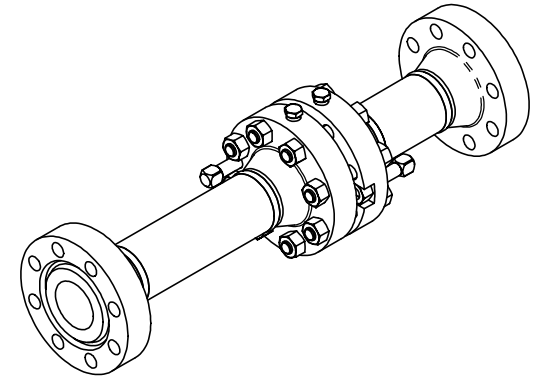
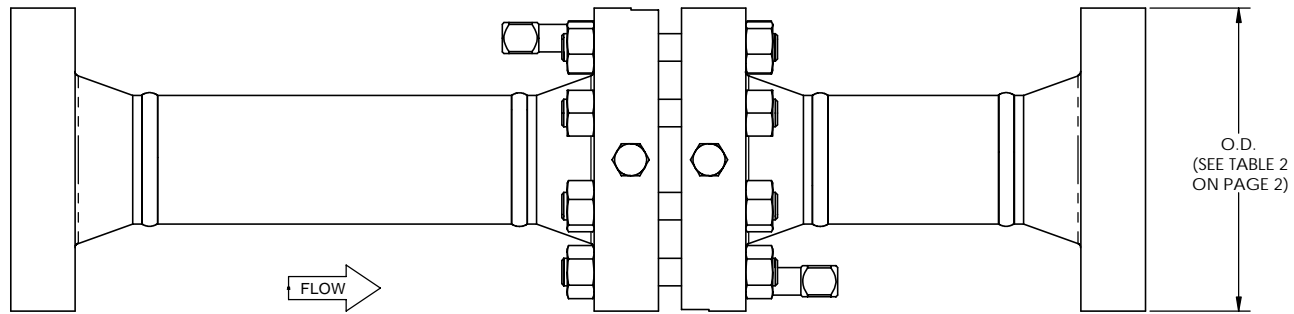

**ORIFICE METER SECTION
WITH FLANGED PIPE ENDS**

ROSEMOUNT®

BOULDER, COLORADO

SIZE A	FSCM.NO.	DRAWING NO. 01497-1002
-----------	----------	---------------------------

SCALE: NONE WT.	SHEET 4 OF 11
-------------------	---------------

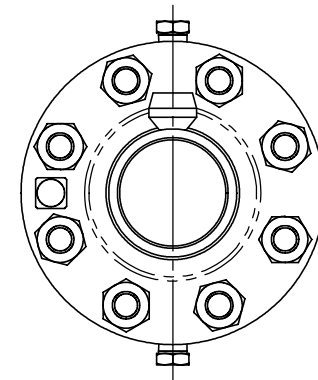
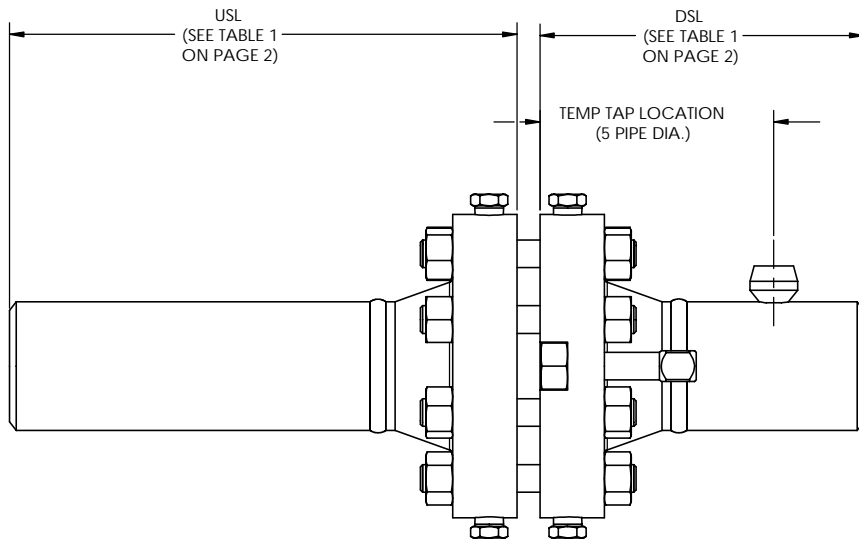
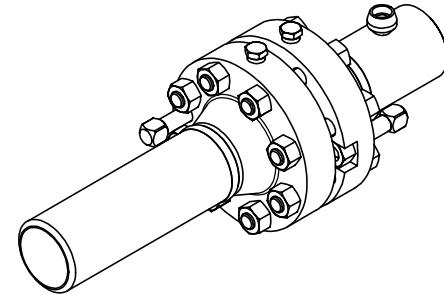
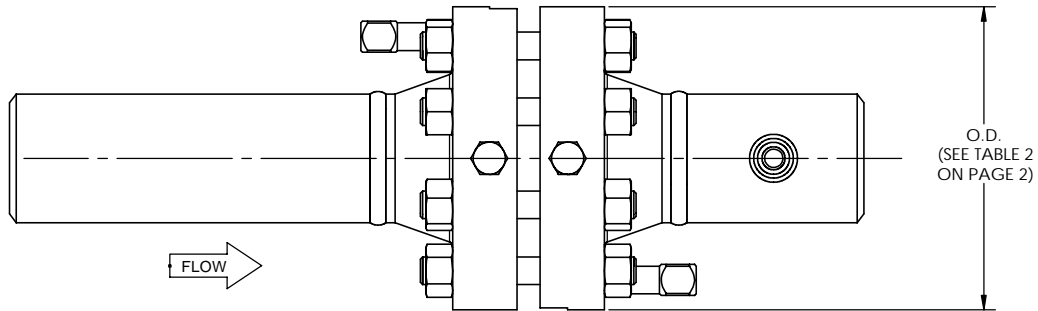

***ORIFICE METER SECTION
WITH BEVELLED PIPE ENDS
AND TEMPERATURE TAP***

ROSEMOUNT®

BOULDER, COLORADO

SIZE A	FSCM.NO.	DRAWING NO. 01497-1002
-----------	----------	---------------------------

SCALE: NONE WT.	SHEET 5 OF 11
-------------------	---------------

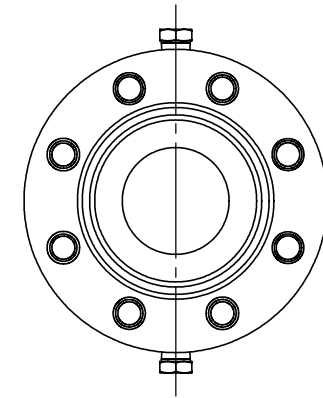
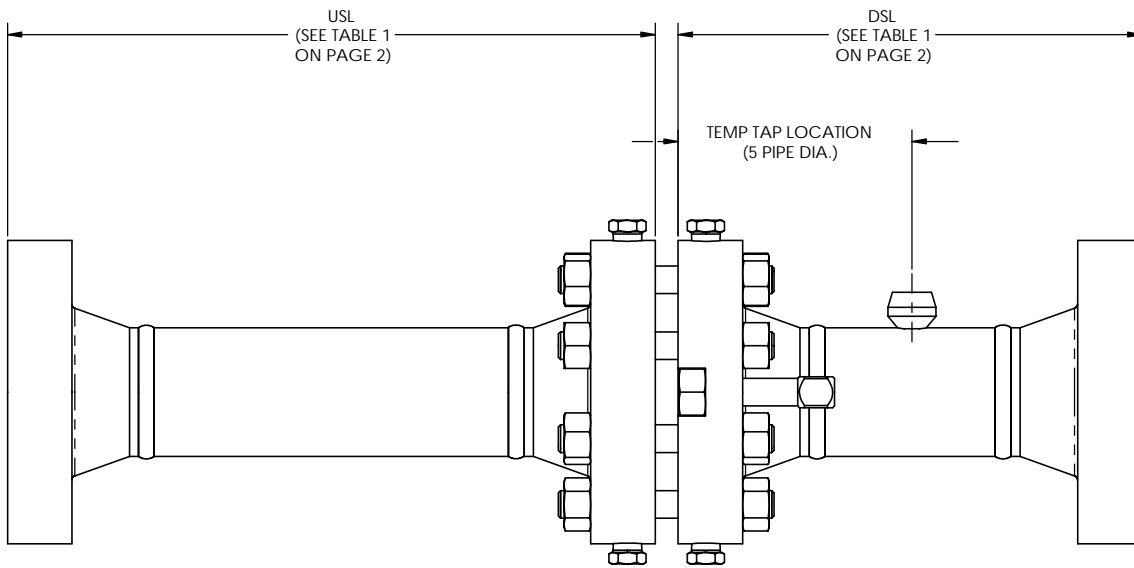
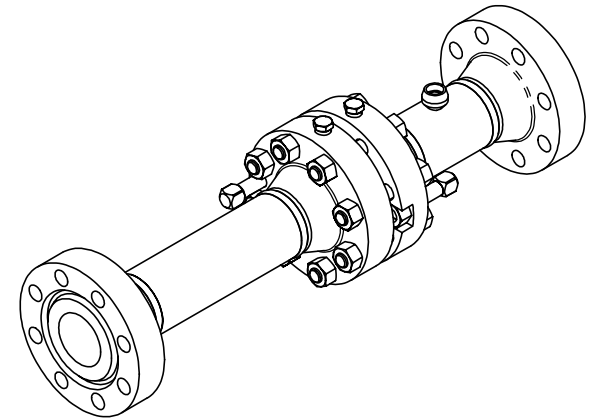
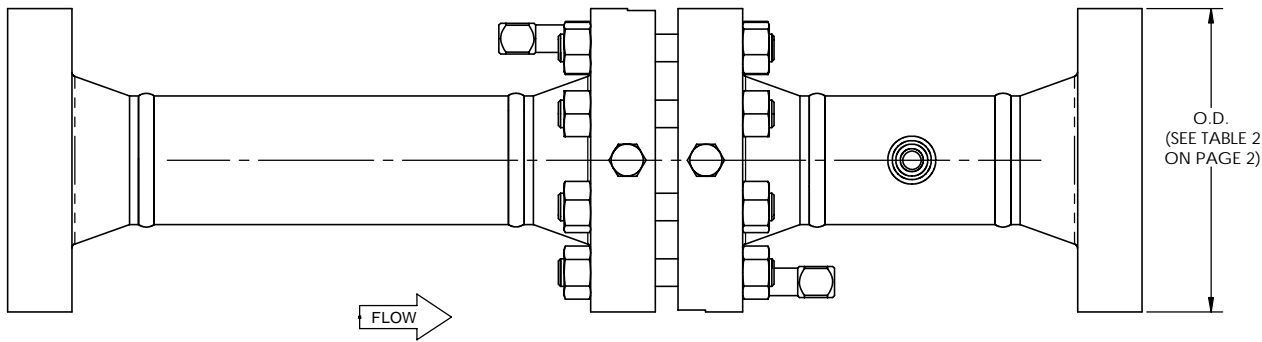

**ORIFICE METER SECTION
WITH FLANGED PIPE ENDS
AND TEMPERATURE TAP**

ROSEMOUNT®
BOULDER, COLORADO

SIZE A	FSCM.NO.	DRAWING NO. 01497-1002
SCALE: NONE WT.		SHEET 6 OF 11

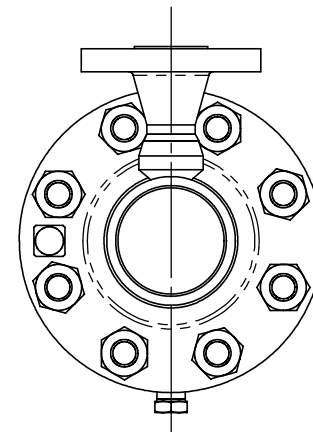
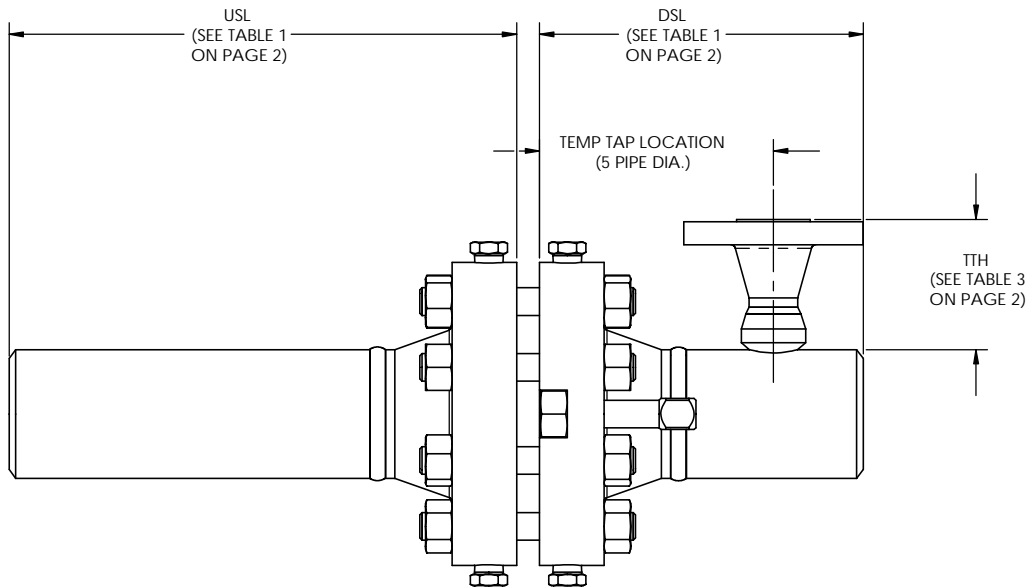
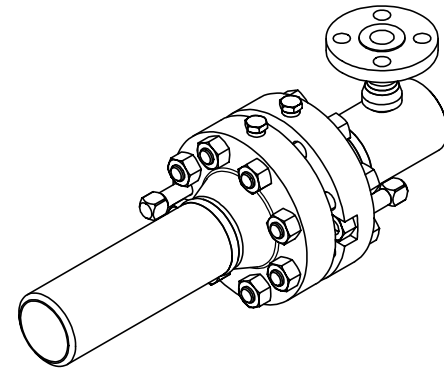
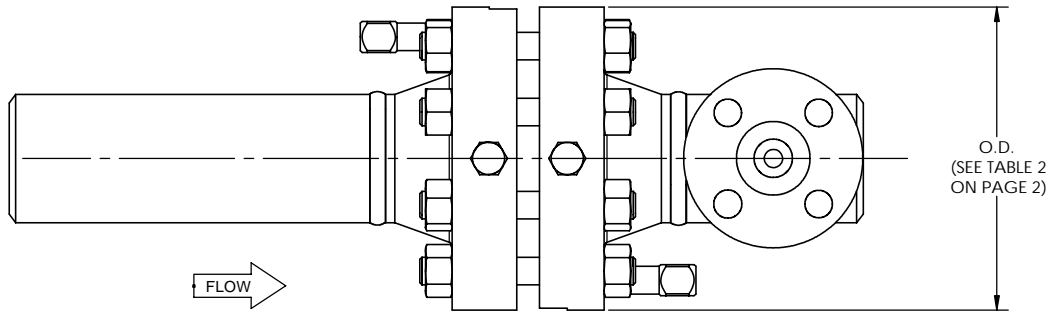

ROSEMOUNT®		
BOULDER, COLORADO		
SIZE A	FSCM.NO.	DRAWING NO. 01497-1002
SCALE: NONE WT.		SHEET 7 OF 11

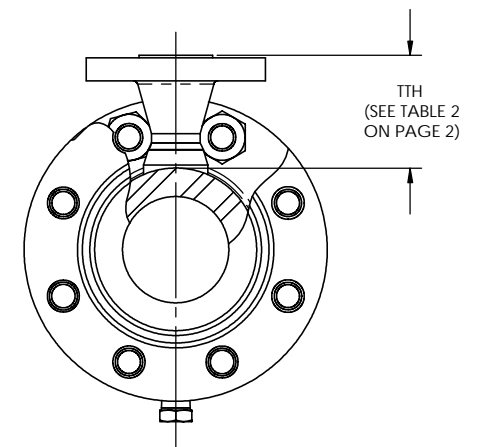
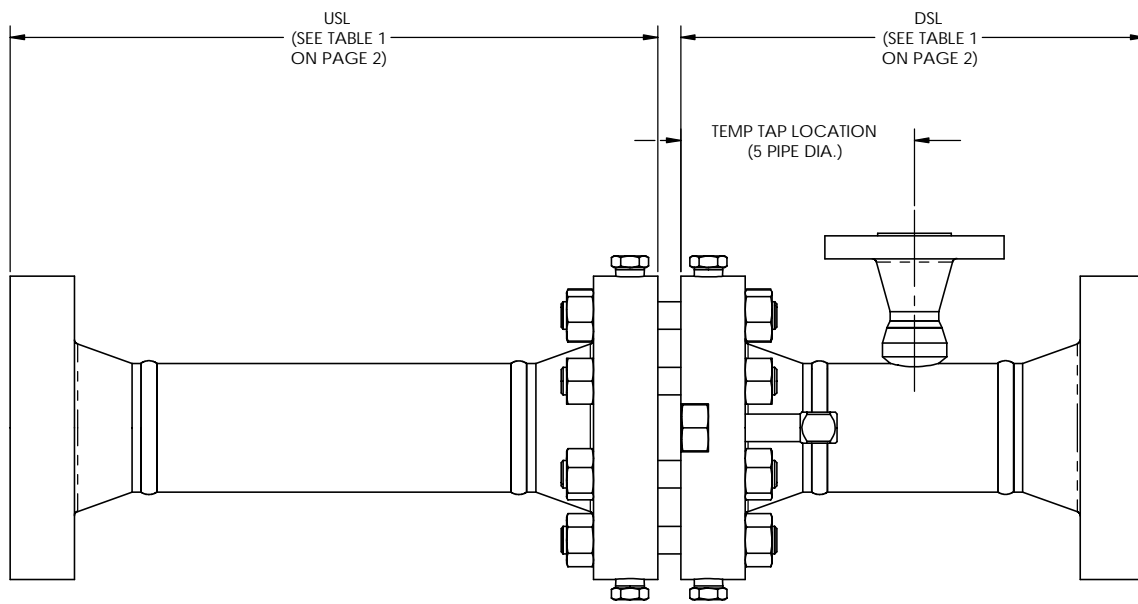
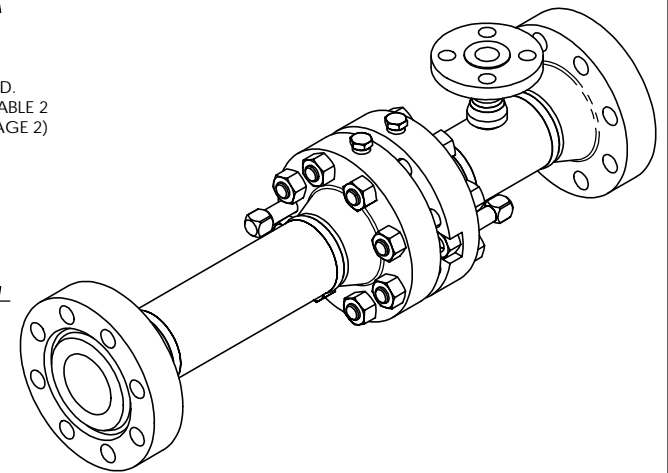
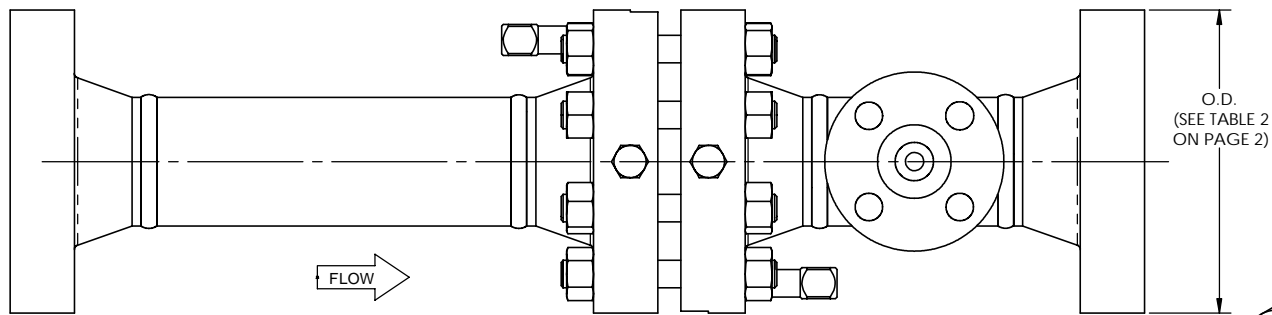

**ORIFICE METER SECTION
WITH FLANGED PIPE ENDS
AND FLANGED TEMPERATURE TAP**

ROSEMOUNT®		
BOULDER, COLORADO		
SIZE A	FSCM.NO.	DRAWING NO. 01497-1002
SCALE: NONE WT.		SHEET 8 OF 11

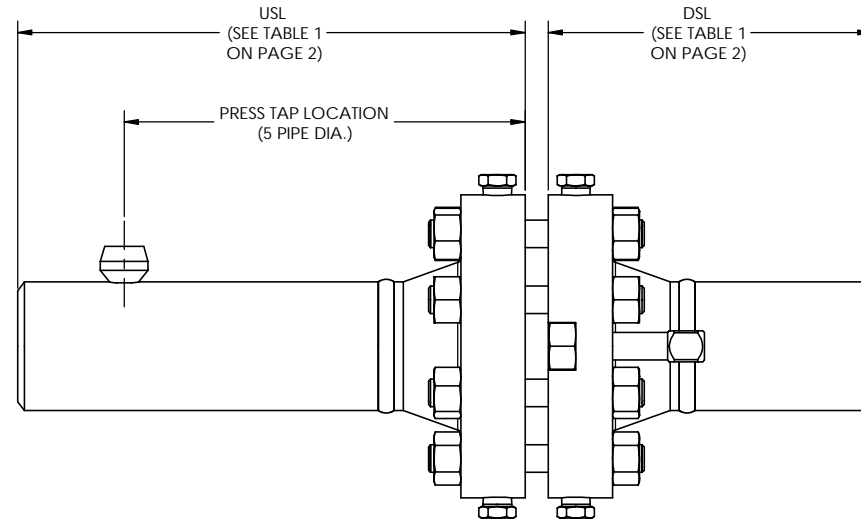
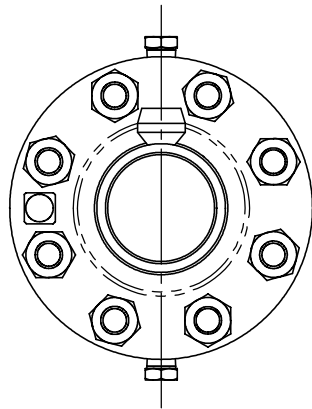
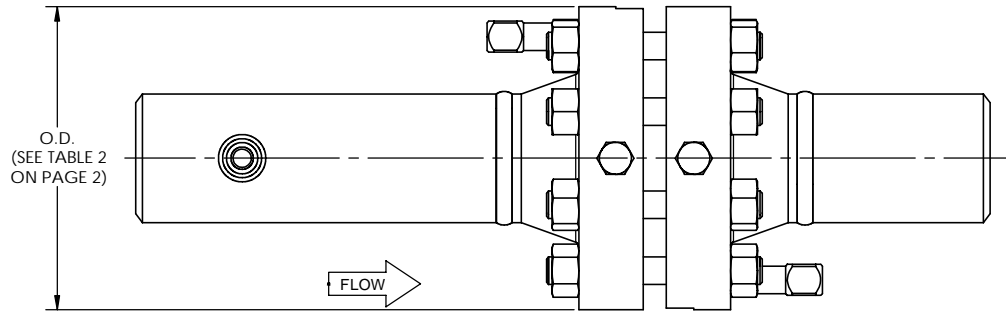
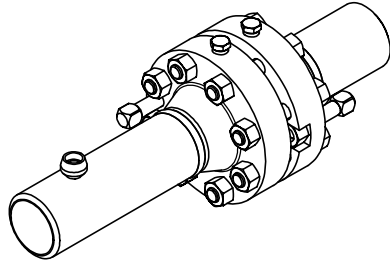

**ORIFICE METER SECTION
WITH BEVELLED PIPE ENDS
AND ADDITIONAL STATIC PRESSURE TAP**

ROSEMOUNT®

BOULDER, COLORADO

SIZE A	FSCM.NO.	DRAWING NO. 01497-1002
-----------	----------	---------------------------

SCALE: NONE | WT.

SHEET 9 OF 11

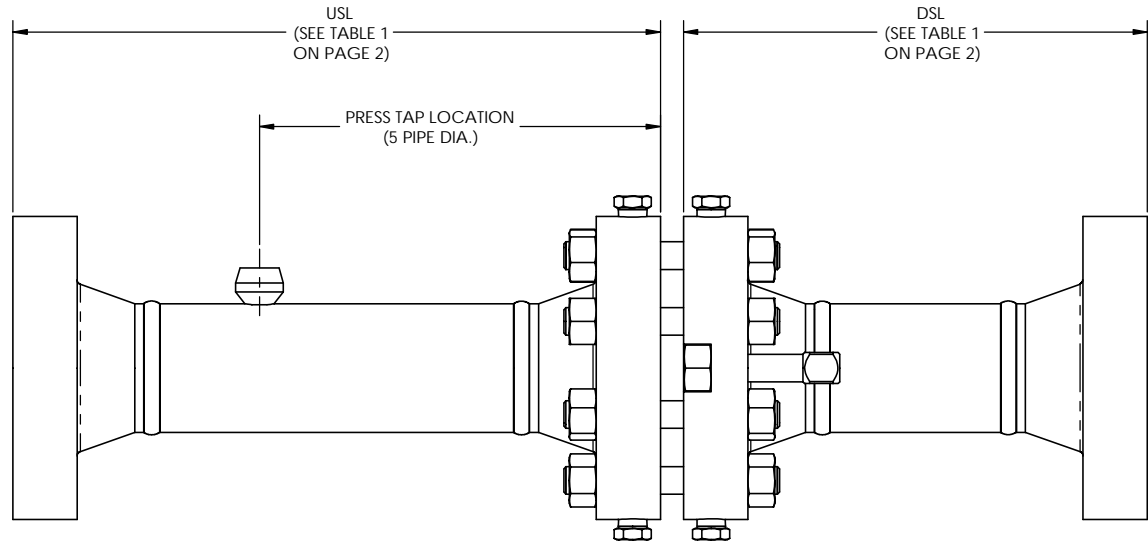
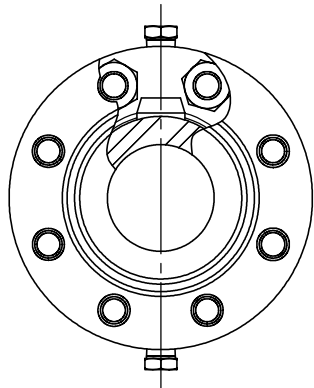
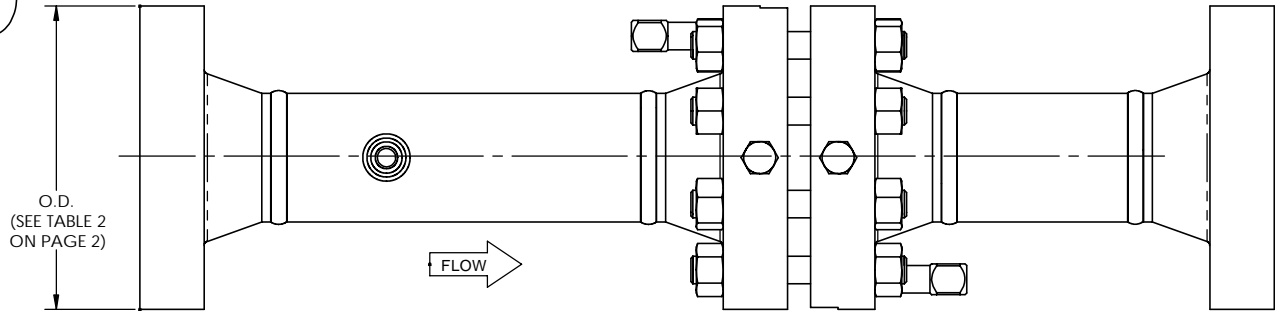
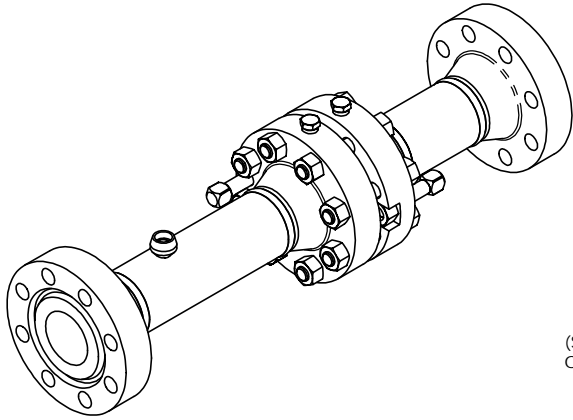

**ORIFICE METER SECTION
WITH FLANGED PIPE ENDS
AND ADDITIONAL STATIC PRESSURE TAP**

ROSEMOUNT®

BOULDER, COLORADO

SIZE A	FSCM.NO.	DRAWING NO. 01497-1002
-----------	----------	----------------------------------

SCALE: NONE | WT.

SHEET 10 OF 11

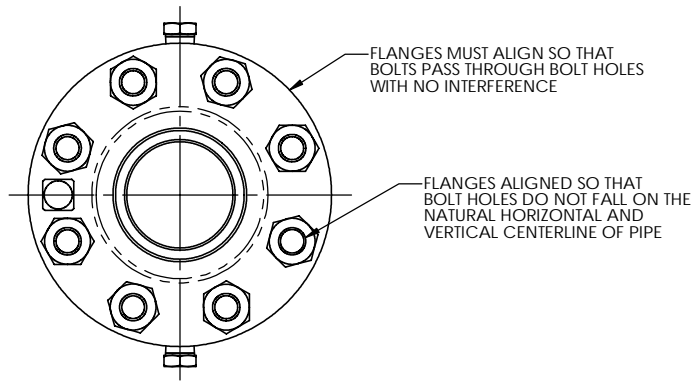

DETAIL A

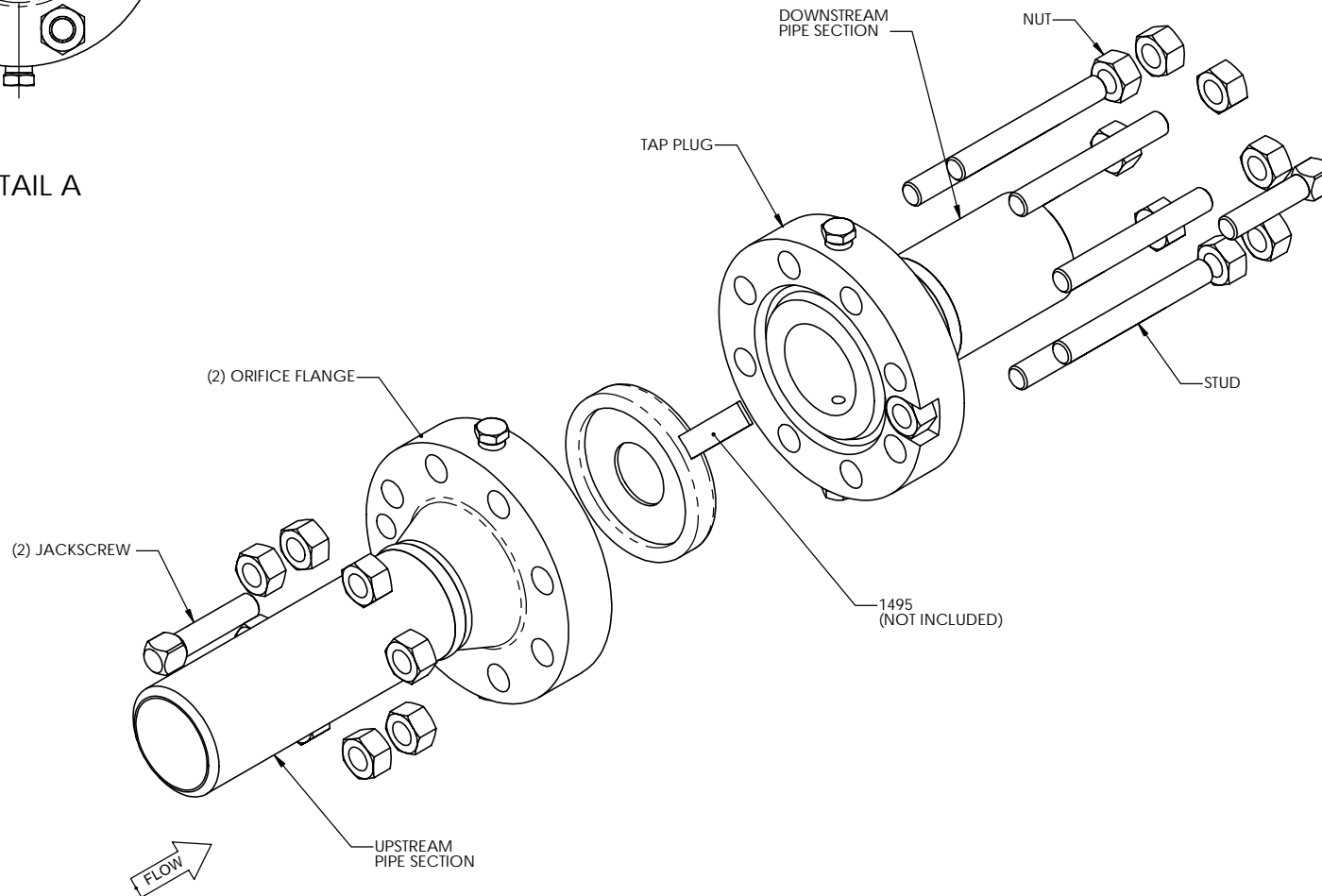

EXPLODED INSTALLATION VIEW

ROSEMOUNT®		
BOULDER, COLORADO		
SIZE A	FSCM.NO.	DRAWING NO. 01497-1002
SCALE: NONE WT.		SHEET 11 OF 11