

Rosemount 3095 *MultiVariable*TM Mass Flow Transmitter

**THE PROVEN LEADER IN MULTIVARIABLE
MASS FLOW MEASUREMENT.**

- 1.0% Mass Flow rate accuracy over 10:1 Flow Range
- Ten year stability under actual process conditions
- Unprecedented reliability backed by a limited 12-year warranty
- Four variables in one device
- “Real-Time” fully-compensated Mass Flow
- CoplanarTM platform enables DP Flowmeters

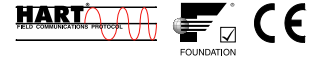

Contents

Specifications	page 3
Product Certifications	page 7
Dimensional Drawings	page 12
Ordering Information	page 14
Rosemount 3095 HART Configuration Data Sheet	page 19
Rosemount 3095 FOUNDATION fieldbus TM Configuration Data Sheet	page 26

The Leader in *MultiVariable* Mass Flow Measurement.

Rosemount delivers a tradition of excellence and technology leadership, featuring the state-of-the-art Rosemount 3095 *MultiVariable* Mass Flow transmitter. The Rosemount 3095 delivers four measurements from one *coplanar* device with unmatched operating performance, including dynamic fully compensated mass flow. Engineered to combine best products with best installation practices, the Rosemount 3095 enables a complete offering of DP Flowmeters.

1.0% of Mass Flow rate accuracy over 10:1 flow range

Enabled by superior sensor technology and engineered for optimal flow performance, the Rosemount 3095 delivers unprecedented $\pm 0.05\%$ DP reading reference accuracy, resulting in mass flow accuracy of $\pm 1.0\%$ over 10:1 flow range. Superior performance means reduced variability and improved plant safety.

Ten year stability of $\pm 0.25\%$

Through aggressive testing, the Rosemount 3095 has proven its ability to maintain unprecedented performance under the most demanding conditions. Superior transmitter stability decreases calibration frequency for reduced maintenance and operation costs.

Unprecedented reliability backed by a limited 12-year warranty

Further enhance installation practices with the most reliable platform supported by a 12-year warranty.

Four variables in one device

The advanced Rosemount 3095 measures three process variables simultaneously and dynamically calculates "real-time" fully compensated mass flow. One transmitter means reduced process penetrations, inventory and installation costs.

"Real-Time" fully-compensated mass flow

Fully compensated mass flow reduces sources of traditional DP flow uncertainty. Rosemount 3095 calculates Mass Flow by measuring process pressure and temperature to perform 'real-time' calculation of all flow equation parameters including density, viscosity, velocity, Reynolds number, beta ratio, discharge coefficient, velocity of approach, and the gas expansion factor. Superior flow calculations yield more accurate measurements to reduce variability and increase profitability.

Coplanar platform enables DP flowmeters

The flexible *coplanar* platform allows integration with the complete offering of Rosemount primary elements for any flow application. The solution arrives factory calibrated, pressure-tested, and ready to install right out of the box. Only Rosemount has a scalable *coplanar* transmitter design to reduce engineering and inventory costs.

Advanced *PlantWeb* functionality



From multiple process variable generation to advanced compensated Mass Flow functionality and highly integrated flowmeter solutions, the 3095 reduces operational and maintenance expenditures while improving throughput and utilities management.

Rosemount DP-Flow Solution

Rosemount 3051S Series of Instrumentation

Scalable pressure, flow and level measurement solutions improve installation and maintenance practices.

Rosemount 305 and 306 Integral Manifolds

Factory-assembled, calibrated and seal-tested manifolds reduce on-site installation costs.

Rosemount 1199 Diaphragm Seals

Provides reliable, remote measurements of process pressure and protects the transmitter from hot, corrosive, or viscous fluids.

Orifice Plate Primary Element Systems: Rosemount 1495 and 1595 Orifice Plates, 1496 Flange Unions and 1497 Meter Sections

A comprehensive offering of orifice plates, flange unions and meter sections that is easy to specify and order. The 1595 Conditioning Orifice provides superior performance in tight fit applications.

Annubar[®] Flowmeter Series: Rosemount 3051SFA, 3095MFA, and 485

The state-of-the-art, fifth generation Rosemount 485 *Annubar* combined with the 3051S or 3095 *MultiVariable* transmitter creates an accurate, repeatable and dependable insertion-type flowmeter.

Compact Orifice Flowmeter Series: Rosemount 3051SFC, 3095MFC, and 405

Compact Orifice Flowmeters can be installed between existing flanges, up to a Class 600 (PN100) rating. In tight fit applications, a conditioning orifice plate version is available, requiring only two diameters of straight run upstream.

ProPlate[®] Flowmeter Series: Rosemount *ProPlate*, Mass *ProPlate*, and 1195

These integral orifice flowmeters eliminate the inaccuracies that become more pronounced in small orifice line installations. The completely assembled, ready to install flowmeters reduce cost and simplify installation.

Specifications

FUNCTIONAL

Service

Gas, liquid, or steam

Differential Sensor

Limits

- Code 1: -25 to 25 inH₂O (-0,062 to 0,062 bar)
- Code 2: -250 to 250 inH₂O (-0,622 to 0,622 bar)
- Code 3: -1000 to 1000 inH₂O (-2,49 to 2,49 bar)

Absolute Sensor

Limits

- Code 3: 0.5 to 800 psia (3,447 to 5516 kPa)
- Code 4: 0.5 to 3,626 psia (3,447 to 25000 kPa)

Gage Sensor

Limits

- Code C: 0-800 psig (0-5516 kPa)
- Code D: 0-3,626 psig (0-25000 kPa)

Temperature Sensor

Process Temperature Range

- -300 to 1500 °F (-184 to 816 °C)

Fixed Temperature Range

- -459 to 3500 °F (-273 to 1927 °C)

Overpressure Limit

0 psia to two times the pressure sensor range with a maximum of 3,626 psia (250 bar).

Static Pressure Limit

Operates within specifications between static line pressures of 0.5 psia and the URL of the absolute pressure sensor.

Temperature Limits

Process (at transmitter isolator flange for atmospheric pressures and above)

- Silicone fill: -40 to 250 °F (-40 to 121 °C)
- Inert fill: 0 to 185 °F (-18 to 85 °C) (Process temperature above 185 °F (85 °C) require derating the ambient limits by a 1.5:1 ratio.)

Ambient:

- -40 to 185 °F (-40 to 85 °C)
- with integral meter: -4 to 175 °F (-20 to 80 °C)

Storage:

- -50 to 230 °F (-46 to 110 °C)
- with integral meter: -40 to 185 °F (-40 to 85 °C)

Damping

Analog output response to step input change can be user-selectable from 0 to 29 seconds for one time constant.

4-20 mA (output option code A)

Zero and Span Adjustment

Zero and span values can be set anywhere within the range. Span must be greater than or equal to the minimum span.

Output

Two-wire 4-20 mA, user-selectable for DP, AP, GP, PT, mass flow, or totalized flow. Digital HART protocol superimposed on 4-20 mA signal, available to any host that conforms to the HART protocol.

Power Supply

External power supply required. Transmitter operates on terminal voltage of 11-55 V dc.

Load Limitations

Maximum loop resistance is determined by the voltage level of the external power supply, as described by:

$$\text{Maximum Loop Resistance} = \frac{\text{Power Supply} - 11.0}{0.022}$$

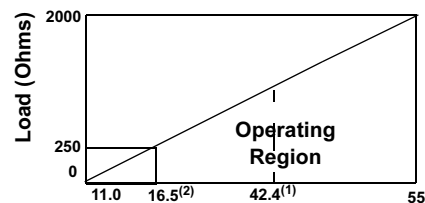

Power Supply

(1) For CSA approval, power supply must not exceed 42.4 V dc.

(2) HART protocol communication requires a loop resistance value between 250-1100 ohms, inclusive.

FOUNDATION fieldbus (output option code V)

Power Supply

External power supply required; transmitters operate on 9.0 to 32.0 V dc transmitter terminal voltage.

Current Draw

17.5 mA for all configurations (including LCD display option)

Humidity Limits

0-100% relative humidity

Turn-on Time

Digital and analog measured variables will be within specifications 7-10 seconds after power is applied to transmitter.

Digital and analog flow output will be within specifications 10-14 seconds after power is applied to transmitter.

Failure Mode Alarm

Output Code A

If self-diagnostics detect a non-recoverable transmitter failure, the analog signal will be driven either below 3.75 mA or above 21.75 mA to alert the user. High or low alarm signal is user-selectable by internal jumper pins.

Output Code V

If self-diagnostics detect a gross transmitter failure, that information gets passed as a status along with the process variable(s).

Configuration

HART Hand-held Communicator (Model 275 or 375)

- Performs traditional transmitter maintenance functions

3095 Multivariable Engineering Assistant (EA) software package

- Contains built-in physical property database
- Enables mass flow configuration, maintenance, and diagnostic functions via HART modem (output option code A)
- Enables mass flow configuration via PCM-CIA Interface for FOUNDATION fieldbus (output option code V)

Primary Elements

Supports over 25 different primary elements including:

- Annubar Averaging Pitot Tube
- Rosemount 1195 Integral Orifice Plate
- Rosemount 405 Compact and Conditioning Orifice
- ISO/ASME Orifice Flange Taps
- Calibrated and Custom Primary Elements
- ISO/ASME Corner Taps
- AGA Flange Taps
- ISO/ASME Venturi
- ISO/ASME Venturi Nozzle
- Area Averaging Meter
- V-Cone

Physical Properties Database

- Maintained in Engineering Assistant Software Configurator
- Physical properties for over 110 fluids
- Natural gas per AGA
- Steam and water per ASME
- Other database fluids per American Institute of Chemical Engineers (AIChE)
- Optional custom entry

FOUNDATION fieldbus Function Blocks

Standard Function Blocks

Resource Block

- Contains hardware, electronics, and diagnostic information.

Transducer Block

- Contains actual sensor measurement data including the sensor diagnostics and the ability to trim the pressure sensor or recall factory defaults.

LCD Block

- Configures the local display.

5 Analog Input Blocks

- Processes the measurements for input into other function blocks. The output value is in engineering or custom units and contains a status indicating measurement quality.

PID Block with Auto-tune

- Contains all logic to perform PID control in the field including cascade and feedforward. Auto-tune capability allows for superior tuning for optimized control performance.

Advanced Control Function Block Suite (Option Code A01)

Input Selector Block

- Selects between inputs and generates an output using specific selection strategies such as minimum, maximum, midpoint, average, or first "good."

Arithmetic Block

- Provides pre-defined application-based equations including flow with partial density compensation, electronic remote seals, hydrostatic tank gauging, ratio control and others.

Signal Characterizer Block

- Characterizes or approximates any function that defines an input/output relationship by configuring up to twenty X, Y coordinates. The block interpolates an output value for a given input value using the curve defined by the configured coordinates.

Integrator Block

- Compares the integrated or accumulated value from one or two variables to pre-trip and trip limits and generates discrete output signals when the limits are reached. This block is useful for calculating total flow, total mass, or volume over time.

Output Splitter Block

- Splits the output of one PID or other control block so that the PID will control two valves or other actuators.

Control Selector Block

- Selects one of up to three inputs (highest, middle, or lowest) that are normally connected to the outputs of PID or other control function blocks.

Steam Flow Calculations

Steam densities calculated per ASME steam tables.

Saturated steam configurable using static pressure based density calculations.

Natural Gas Flow Calculations

Flow calculations per 1992 AGA (American Gas Association) Report No 3 or ISO-5167 (2003).

Compressibility Calculations per AGA Report No 8 or ISO-12213.

Product Data Sheet

00813-0100-4716, Rev KA

Catalog 2006 - 2007

Rosemount 3095 MultiVariable

PERFORMANCE

(Zero-based spans, reference conditions, silicone oil fill, 316 SST isolating diaphragms, 4–20 mA analog output.)

Specification Conformance

The Rosemount 3095 maintains a specification conformance of measured variables to at least 3σ .

Mass Flow

Fully compensated for pressure, temperature, density, viscosity gas expansion, discharge coefficient, and thermal correction variances over operating range.

$$Q_m = N C_d E Y_1 d^2 \{DP(p)\}^{1/2}$$

Ultra for Flow: Mass Flow Reference Accuracy (option U3)⁽¹⁾

- $\pm 1.0\%$ of Mass Flow Rate over a 10:1 flow range (100:1 DP range for liquids and gases)

Mass Flow Reference Accuracy

- $\pm 1.0\%$ of Mass Flow Rate over 8:1 flow range (64:1 DP range for liquids and gases)

Totalized Mass Flow

- $\pm 1.0\%$ of Total Mass Flow

(Uncalibrated differential producer (Orifice) installed per ASME MFC3M or ISO 5167-1. Uncertainties for discharge coefficient, producer bore, tube diameter, and gas expansion factor defined in ASME MFC3M or ISO 5167-1. Density uncertainty of 0.1%. Differential pressure calibrated at up to 1/10th full scale for optimum flow accuracy/rangeability.)

Differential Pressure (DP)

Range 1

- 0–0.5 to 0–25 inH₂O (0–1,25 to 0–62,3 mbar) (50:1 rangeability is allowed)

Range 2

- 0–2.5 to 0–250 inH₂O (0–6,22 to 0–622,7 mbar) (100:1 rangeability is allowed)

Range 3

- 0–10 to 0–1000 inH₂O (0–24,9 to 0–2490,9 mbar) (100:1 rangeability is allowed)

Reference Accuracy (including Linearity, Hysteresis, Repeatability)⁽²⁾

Range 2-3 Ultra for Flow (Option U3)⁽¹⁾

- $\pm 0.05\%$ DP reading for rangedown from 1:1 to 3:1 of URL
- For rangedown greater than 3:1 of URL,

$$\text{Accuracy} = \pm \left[0.05 + 0.0145 \left(\frac{URL}{Reading} \right) \right] \% \text{ Reading}$$

Range 2-3

- $\pm 0.075\%$ of span for spans from 1:1 to 10:1 of URL
- For rangedowns greater than 10:1 of URL,

$$\text{Accuracy} = \pm \left[0.025 + 0.005 \left(\frac{URL}{Span} \right) \right] \% \text{ of Span}$$

Range 1

- $\pm 0.10\%$ of span for spans from 1:1 to 15:1 of URL
- For rangedowns greater than 15:1 of URL,

$$\text{Accuracy} = \pm \left[0.025 + 0.005 \left(\frac{URL}{Span} \right) \right] \% \text{ of Span}$$

Ambient Temperature Effect per 50 °F (28 °C)

Range 2-3 Ultra for Flow (Option U3)⁽²⁾

- $\pm 0.130\%$ reading for rangedown from 1:1 to 3:1 of URL
- $\pm [0.05 + 0.0345 (URL/Reading)]\%$ Reading > 3:1 to 100:1 of URL

Range 2-3

- $\pm (0.025\% \text{ of URL} + 0.125\% \text{ of span})$ for spans from 1:1 to 30:1
- $\pm (0.035\% \text{ of URL} - 0.175\% \text{ of span})$ for spans from 30:1 to 100:1

Range 1

- $\pm (0.20\% \text{ of URL} + 0.25\% \text{ of span})$ for spans from 1:1 to 30:1
- $\pm (0.24\% \text{ of URL} + 0.15\% \text{ of span})$ for spans from 30:1 to 50:1

Static Pressure Effects

Range 2-3

- Zero error = $\pm 0.05\%$ of URL per 1,000 psi (68,9 bar)
- Span error = $\pm 0.20\%$ of reading per 1,000 psi (68,9 bar)

Range 1

- Zero error = $\pm 0.05\%$ of URL per 800 psi (55,1 bar)
- Span error = $\pm 0.40\%$ of reading per 800 psi (55,1 bar)

DP Stability

Range 2-3 Ultra for Flow (Option U3)

- $\pm 0.25\%$ of URL for 10 years for ± 50 °F (28 °C) temperature changes, up to 1000 psi (68,9 bar) line pressure

Ranges 2-3

- $\pm 0.125\%$ URL for 5 years for ± 50 °F (28 °C) ambient temperature changes, and up to 1000 psi (68,9 bar) line pressure.

Range 1

- $\pm 0.2\%$ of URL for 1 year

Absolute/Gage Pressure

Absolute (100:1 rangeability allowed)

Range 3

0.5–8 to 0.5–800 psia (3,447–55,16 to 3,447–5516 kPa)

Range 4

0.5–36.26 to 0.5–3,626 psia (3,447–250 to 3,447–25000 kPa)

Gage (100:1 rangeability allowed)

Range C

0–8 to 0–800 psig (0–55,16 to 0–5516 kPa)

Range D

- 0–36.26 to 0–3,626 psig (0–250 to 0–25000 kPa)

Reference Accuracy

(including Linearity, Hysteresis, Repeatability)

$\pm 0.075\%$ of span for spans from 1:1 to 10:1 of URL

For rangedowns greater than 10:1 of URL,

$$\text{Accuracy} = \pm \left[0.03 + 0.0075 \left(\frac{URL}{Span} \right) \right] \% \text{ of Span}$$

Ambient Temperature Effect per 50 °F (28 °C)

$\pm (0.050\% \text{ of URL} + 0.125\% \text{ of span})$ spans from 1:1 to 30:1

$\pm (0.060\% \text{ of URL} - 0.175\% \text{ of span})$ spans from 30:1 to 100:1

(1) Ultra for Flow (option U3) applicable for HART protocol, DP ranges 2 and 3 with SST isolator material and silicone fill fluid options only.

(2) For FOUNDATION fieldbus transmitters, use calibrated range in place of span.

Rosemount 3095 MultiVariable

Stability

±0.125% URL for 5 years for ±50°F (28 °C) ambient temperature changes, and up to 1000 psi (6,9MPa) line pressure.

Process Temperature (PT)

Specification for process temperature is for the transmitter portion only. Sensor errors caused by the RTD are not included. The transmitter is compatible with any PT100 RTD conforming to IEC 751 Class B, which has a nominal resistance of 100 ohms at 0 °C and $\alpha = 0.00385$. Examples of compatible RTDs include the Rosemount Series 68 and 78 RTD Temperature Sensors.

RTD Range

–300 to 1500°F (–184 to 816 °C)

PT Accuracy

(including Linearity, Hysteresis, Repeatability)

For 12 and 24 ft. Cables

- ±1.0 °F (0.56 °C) for process temperatures from –300 to 1200 °F (–184 to 649 °C)
- For process temperatures above 1200 °F (649 °C), add ±1.0 °F (0.56 °C) per 100 °F (38 °C)

For 75 ft. cables:

- ±2.0 °F (1.12 °C) for process temperatures from –300 to 1200 °F (–184 to 649 °C)
- For process temperatures above 1200 °F (649 °C), add ±1.0 °F (0.56 °C) per 100 °F (38 °C)

PT Stability

±1.0 °F (0.56 °C) for 12 months

Physical

Security

Transmitter security jumper mounted on electronics board, when enabled prevents changes to transmitter configuration.

User Engineering Assistant provides two levels of optional password security

Electrical Connections

½–14 NPT, M20 × 1.5 (CM20), PG-13.5. HART interface connections fixed to terminal block for output code A.

RTD Process Temperature Input

100-ohm platinum RTD per IEC-751 Class B

Process Connections

Transmitter: ¼–18 NPT on 2¹/₈-in. centers 1/2–14 NPT on 2-, 2¹/₈-, or 2¹/₄-in. centers with optional flange adapters
RTD: RTD dependent.

Process Wetted Parts

Isolating Diaphragms

- 316L SST or *Hastelloy C-276*®. CF-8M (last version of 316 SST, material per ASTM-A743)

Drain/Vent Valves

- 316 SST or *Hastelloy C*®

Flanges

- Plated carbon steel, 316 SST, or *Hastelloy C*

Wetted O-rings

- Glass-Filled TFE

Non-Wetted Parts

Electronics Housing

- Low copper aluminum. NEMA 4X, CSA, Enclosure Type 4X, IP 65, IP 66, IP 68

Bolts

- Plated carbon steel per ASTM A449, Grade 5 or austenitic 316 SST

Fill Fluid

- Silicone or halocarbon inert oil (Inert oil only available for gage sensor modules.)

Paint (Aluminum Housing only)

- Polyurethane

O-rings

- Buna-N

Weight

Component	Weight in lb (kg)
Rosemount 3095 Transmitter	6.0 (2.7)
SST Mounting Bracket	1.0 (0.4)
12 ft (3.66 m) RTD Shielded Cable	0.5 (0.2)
12 ft (3.66 m) RTD Armored Cable	1.1 (0.5)
24 ft (7.32 m) RTD Shielded Cable	1.0 (0.4)
24 ft (7.32 m) RTD Armored Cable	2.2 (1.0)
75 ft (22.86 m) RTD Shielded Cable	1.9 (0.9)
75 ft (22.86 m) RTD Armored Cable	7.2 (3.2)
21 in (53 cm) RTD Armored Cable	0.5 (0.2)
12 ft (3.66 m) RTD CENELEC Cable	2.1 (0.9)
24 ft (7.32 m) RTD CENELEC Cable	3.0 (1.4)
75 ft (22.86 m) RTD CENELEC Cable	7.1 (3.2)
21 in (53 cm) RTD CENELEC Cable	1.2 (0.5)
4 ft (1.22 m) RTD Shielded Cable	0.17 (.07)

Product Certifications

ROSEMOUNT 3095 WITH HART

Approved Manufacturing Locations

Rosemount Inc. — Chanhassen, Minnesota USA
Emerson Process Management GmbH & Co. — Wessling,
Germany
Emerson Process Management Asia Pacific
Private Limited — Singapore
Beijing Rosemount Far East Instrument Co., Limited – Beijing,
China

European Directive Information

The EC declaration of conformity for all applicable European directives for this product can be found on the Rosemount website at www.rosemount.com. A hard copy may be obtained by contacting our local sales office.

ATEX Directive (94/9/EC)

Emerson Process Management complies with the ATEX Directive.

European Pressure Equipment Directive (PED) (97/23/EC)

3095F_2/3,4/D and 3095M_2/3,4/D Flow Transmitters — QS
Certificate of Assessment - EC No. PED-H-20 Module H
Conformity Assessment

All other 3095_ Transmitters/Level Controller — Sound
Engineering Practice

Transmitter Attachments: Process Flange - Manifold —
Sound Engineering Practice

Electro Magnetic Compatibility (EMC) (89/336/EEC)

3095 Flow Transmitters
— EN 50081-1: 1992; EN 50082-2:1995;
EN 61326-1:1997 – Industrial

Ordinary Location Certification for Factory Mutual

As standard, the transmitter has been examined and tested to determine that the design meets basic electrical, mechanical, and fire protection requirements by FM, a nationally recognized testing laboratory (NRTL) as accredited by the Federal Occupational Safety and Health Administration (OSHA).

Rosemount 3095 HART Hazardous Locations Certifications

North American Certifications

FM Approvals

A Explosion Proof for Class I, Division 1, Groups B, C, and D. Dust-Ignition Proof for Class II/Class III, Division 1, Groups E, F, and G. Enclosure type NEMA 4X. Factory Sealed. Provides nonincendive RTD connections for Class I, Division 2, Groups A, B, C, and D.

J Intrinsically Safe for use in Class I, II and III, Division 1, Groups A, B, C, D, E, F, and G hazardous outdoor locations. Non-incendive for Class I, Division 2, Groups A, B, C, and D. Temperature Code T4. Factory Sealed.

For input parameters and installation see control drawing 03095-1020.

Canadian Standards Association (CSA)

C Explosion Proof for Class I, Division 1, Groups B, C, and D. Dust-Ignition Proof for Class II/Class III, Division 1, Groups E, F, and G. CSA enclosure Type 4X suitable for indoor and outdoor hazardous locations. Provides nonincendive RTD connection for Class I, Division 2, Groups A, B, C, and D. Factory Sealed. Install in accordance with Rosemount Drawing 03095-1024. Approved for Class I, Division 2, Groups A, B, C, and D.

K Intrinsically Safe for Class I, Division 1, Groups A, B, C, and D. when installed in accordance with Rosemount drawing 03095-1021. Temperature Code T3C.

For input parameters and installation see control drawing 03095-1021.

European Certifications

F ATEX Intrinsic Safety

Certificate Number: BAS98ATEX1359X  II 1 G

EEx ia IIC T5 ($T_{amb} = -45\text{ °C to }40\text{ °C}$)

EEx ia IIC T4 ($T_{amb} = -45\text{ °C to }70\text{ °C}$)

CE 1180

TABLE 1. Connection Parameters
(Power/Signal Terminals)

$U_i = 30\text{ V}$

$I_i = 200\text{ mA}$

$P_i = 1.0\text{ W}$

$C_i = 0.012\text{ }\mu\text{F}$

$L_i = 0$

TABLE 2. Temperature Sensor Connection Parameters

$U_o = 30\text{ V}$

$I_o = 19\text{ mA}$

$P_o = 140\text{ mW}$

$C_i = 0.002\text{ }\mu\text{F}$

$L_i = 0$

Rosemount 3095 MultiVariable

TABLE 3. Connection Parameters for Temperature Sensor Terminals

$C_o = 0.066 \mu\text{F}$	Gas Group IIC
$C_o = 0.560 \mu\text{F}$	Gas Group IIB
$C_o = 1.82 \mu\text{F}$	Gas Group IIA
$L_o = 96 \text{ mH}$	Gas Group IIC
$L_o = 365 \text{ mH}$	Gas Group IIB
$L_o = 696 \text{ mH}$	Gas Group IIA
$L_o/R_o = 247 \mu\text{H}/\text{ohm}$	Gas Group IIC
$L_o/R_o = 633 \mu\text{H}/\text{ohm}$	Gas Group IIB
$L_o/R_o = 633 \mu\text{H}/\text{ohm}$	Gas Group IIA

- D** C and K combination
L F, G, H, and P combination

Special Conditions for Safe Use

The 3095, when fitted with the transient terminal block (order code B), are not capable of withstanding the 500 volts insulation test required by EN50 020, Clause 6.4.12 (1994). This condition must be accounted for during installation.

G ATEX Type N

Certificate Number: BAS98ATEX3360X  II 3 G

EEx nL IIC T5 ($T_{\text{amb}} = -45^\circ\text{C}$ to 40°C)

EEx nL IIC T4 ($T_{\text{amb}} = -45^\circ\text{C}$ to 70°C)

$U_i = 55\text{V}$



The apparatus is designed for connection to a remote temperature sensor such as a resistance temperature detection (RTD)

Special Conditions for Safe Use

The 3095, when fitted with the transient terminal block (order code B), are not capable of withstanding the 500 volts insulation test required by EN50 021, Clause 9.1 (1995). This condition must be accounted for during installation.

H ATEX Flameproof

Certificate Number: KEMA02ATEX2320X  II 1/2 G

EEx d IIC T5 ($-50^\circ\text{C} \leq T_{\text{amb}} \leq 80^\circ\text{C}$)

T6 ($-50^\circ\text{C} \leq T_{\text{amb}} \leq 65^\circ\text{C}$)

 1180

Special Conditions for Safe Use (x):

The device contains a thin wall diaphragm. Installation, maintenance, and use shall take into account the environmental conditions to which the diaphragm will be subjected. The manufacturer's instructions for installation and maintenance shall be followed in detail to assure safety during its expected lifetime.

P ATEX Dust

Certificate Number: KEMA02ATEX2321  II 1 D

$V = 55 \text{ Vdc MAX}$

$I = 23 \text{ mA MAX}$

IP66

 1180

Combinations of Certifications

Stainless steel certification tag is provided when optional approval is specified. Once a device labeled with multiple approval types is installed, it should not be reinstalled using any other approval types. Permanently mark the approval label to distinguish it from unused approval types.

- B** A and J combination

ROSEMOUNT 3095 WITH *FIELD*BUS

Approved Manufacturing Locations

Rosemount Inc. — Chanhassen, Minnesota USA

European Directive Information

The EC declaration of conformity for all applicable European directives for this product can be found on the Rosemount website at www.rosemount.com. A hard copy may be obtained by contacting our local sales office.

ATEX Directive (94/9/EC)

Emerson Process Management complies with the ATEX Directive.

European Pressure Equipment Directive (PED) (97/23/EC)

3095F_2/3,4/D and 3095M_2/3,4/D Flow Transmitters

— QS Certificate of Assessment - EC No. PED-H-20
Module H Conformity Assessment

All other 3095_ Transmitters/Level Controller

— Sound Engineering Practice

Transmitter Attachments: Process Flange - Manifold

— Sound Engineering Practice

Primary Elements, Flowmeter

— See appropriate Primary Element QIG

Electro Magnetic Compatibility (EMC) (89/336/EEC)

3095 Flow Transmitters

— EN 50081-1: 1992; EN 50082-2:1995; EN 61326-1:1997 –
Industrial

Ordinary Location Certification for Factory Mutual

As standard, the transmitter has been examined and tested to determine that the design meets basic electrical, mechanical, and fire protection requirements by FM, a nationally recognized testing laboratory (NRTL) as accredited by the Federal Occupational Safety and Health Administration (OSHA).

Rosemount 3095 Fieldbus Hazardous Locations Certifications

North American Certifications

FM Approvals

- A** Explosion Proof for Class I, Division 1, Groups B, C, and D. Dust-Ignition Proof for Class II/Class III, Division 1, Groups E, F, and G. Enclosure type NEMA 4X. Factory Sealed. Provides nonincendive RTD connections for Class I, Division 2, Groups A, B, C, and D.
- J** Intrinsically Safe for use in Class I, II and III, Division 1, Groups A, B, C, D, E, F, and G hazardous outdoor locations. Non-incendive for Class I, Division 2, Groups A, B, C, and D. Temperature Code T4. Factory Sealed.

For input parameters and installation see control drawing 03095-1020.

- V** FISCO for use in Class I, II and III, Division 1, Groups A, B, C, D, E, F, and G hazardous outdoor locations. Temperature Code T4. Factory Sealed.

For input parameters and installation see control drawing 03095-1020.

Canadian Standards Association (CSA)

- C** Explosion Proof for Class I, Division 1, Groups B, C, and D. Dust-Ignition Proof for Class II/Class III, Division 1, Groups E, F, and G. Factory Sealed. CSA enclosure Type 4X for indoor and outdoor hazardous locations. Suitable for Class I, Division 2, Groups A, B, C, and D. Install in accordance with Rosemount Drawing 03095-1024.
- K** Intrinsically Safe for Class I, Division 1, Groups A, B, C, and D. When installed in accordance with Rosemount Drawing 03095-1021. Temperature Code T3C.
- W** FISCO Field Device. Intrinsically Safe for Class I, Division 1, Groups A, B, C, and D. When installed in accordance with Rosemount Drawing 03095-1021. Temperature Code T3C.

European Certifications

F/T ATEX Intrinsic Safety Certificate Number:
Baseefa 05ATEX0022X

⊕ II 1 G

EEx ia IIC T5 ($T_{amb} = -45^{\circ}\text{C}$ to 40°C)

EEx ia IIC T4 ($T_{amb} = -45^{\circ}\text{C}$ to 70°C)

CE 1180

TABLE 4. Connection Parameters (Power/Signal Terminals)

Fieldbus (F Option)	FISCO (T Option)
$U_i = 30V$	$U_i = 17.5V$
$I_i = 300\text{ mA}$	$I_i = 380\text{ mA}$
$P_i = 1.3\text{ W}$	$P_i = 5.32\text{ W}$
$C_i = 3.3\text{ nF}$	$C_i \leq 5\text{ nF}$
$L_i = 0$	$L_i = 10\text{ }\mu\text{H}$

TABLE 5. Temperature Sensor Connection Parameters

$U_o = 30V$
$I_o = 19\text{ mA}$
$P_o = 140\text{ mW}$

TABLE 6. Connection Parameters for Temperature Sensor Terminals

$C_o = 0.066\text{ }\mu\text{F}$	Gas Group IIC
$C_o = 0.560\text{ }\mu\text{F}$	Gas Group IIB
$C_o = 1.82\text{ }\mu\text{F}$	Gas Group IIA
$L_o = 96\text{ mH}$	Gas Group IIC
$L_o = 365\text{ mH}$	Gas Group IIB
$L_o = 696\text{ mH}$	Gas Group IIA
$L_o/R_o = 247\text{ }\mu\text{H}/\text{ohm}$	Gas Group IIC
$L_o/R_o = 633\text{ }\mu\text{H}/\text{ohm}$	Gas Group IIB
$L_o/R_o = 633\text{ }\mu\text{H}/\text{ohm}$	Gas Group IIA

Special Conditions for Safe Use

Versions of the apparatus fitted with the transient protected terminals are not capable of withstanding the 500 volts insulation test required by Clause 6.4.12 of EN 50020:2002. This must be taken into account when installing the apparatus.

G ATEX Type N

Certificate Number: Baseefa05ATEX0023X

Ⓔ II 3 G

EEx nA nL IIC T5 ($T_{amb} = -45\text{ }^\circ\text{C}$ to $40\text{ }^\circ\text{C}$)

EEx nA nL IIC T4 ($T_{amb} = -45\text{ }^\circ\text{C}$ to $70\text{ }^\circ\text{C}$)

$U_i = 55V$

RTD Terminals - The apparatus is designed for connection to a remote temperature sensor such as a resistance temperature detection (RTD).

Special Conditions for Safe Use

Versions of the apparatus fitted with the transient protected terminals are not capable of withstanding the 500 volts insulation test required by Clause 8.1 of EN 60079-15:2003. This must be taken into account when installing the apparatus.

H ATEX Flameproof

Certificate Number: KEMA02ATEX2320X

Ⓔ II 1/2 G

EEx d IIC T5 ($-50\text{ }^\circ\text{C} \leq T_{amb} \leq 80\text{ }^\circ\text{C}$)

T6 ($-50\text{ }^\circ\text{C} \leq T_{amb} \leq 65\text{ }^\circ\text{C}$)

$V_{max} = 55\text{ Vdc MAX}$

$I_{max} = 23\text{ mA MAX}$

IP66

CE 1180

Special Conditions for Safe Use (x):

The device contains a thin wall diaphragm. Installation, maintenance, and use shall take into account the environmental conditions to which the diaphragm will be subjected. The manufacturer's instructions for installation and maintenance shall be followed in detail to assure safety during its expected lifetime.

P ATEX Dust

Certificate Number: KEMA02ATEX2321

Ⓔ II 1 D T90°C ($-50\text{ }^\circ\text{C} \leq T_{amb} \leq 80\text{ }^\circ\text{C}$)

$V_{max} = 55\text{ Vdc}$

$I_{max} = 23\text{ mA}$

IP66

CE 1180

Combinations of Certifications

Stainless steel certification tag is provided when optional approval is specified. Once a device labeled with multiple approval types is installed, it should not be reinstalled using any other approval types. Permanently mark the approval label to distinguish it from unused approval types.

B A and J combination

D C and K combination

L F, G, H, and P combination

Australian Certifications

International IECEx Certification (Fieldbus)

Intrinsic Safety

4/Y Certificate Number: IECEx BAS05.0023X

Ex ia IIC T4 ($-45\text{ }^\circ\text{C} \leq T_a \leq 70\text{ }^\circ\text{C}$)

Ex ia IIC T5 ($-45\text{ }^\circ\text{C} \leq T_a \leq 40\text{ }^\circ\text{C}$)

TABLE 7. Input Parameters

Fieldbus I.S.	FISCO
$U_i = 30Vdc$	$U_i = 17.5Vdc$
$I_i = 300\text{ mAdc}$	$I_i = 380\text{ mAdc}$
$P_i = 1.3\text{ W}$	$P_i = 5.32\text{ W}$
$C_i = 3.3\text{ nF}$	$C_i < 5\text{ nF}$
$L_i = 0$	$L_i < 10\text{ nF}$

TABLE 8. RTD Terminals Entity Parameters

$U_o = 30Vdc$
$I_o = 19\text{ mAdc}$
$P_o = 140\text{ mW}$

Product Data Sheet

00813-0100-4716, Rev KA
Catalog 2006 - 2007

Rosemount 3095 MultiVariable

The capacitance and either the Inductance or the Inductance to Resistance Ratio (L/R) of the load connected to the 4-pin connector must not exceed the following values:

Group	Capacitance (μ F)	Inductance (mH)	or L/R Ratio μ H/Ohm
IIC	0.066	96	247
IIB	0.56	365	633
IIA	1.82	696	633

Conditions of Certification:

When fitted with the transient option, the apparatus is not capable of withstanding the 500V electrical strength test as defined in Clause 6.4.12 of IEC 60079-11: 1999. This must be taken into account during installation.

Non-Incendive

5 Certificate Number: IECEx BAS05.0024X

Ex nC IIC T4 ($-45^{\circ}\text{C} \leq T_a \leq 70^{\circ}\text{C}$)

Ex nC IIC T5 ($-45^{\circ}\text{C} \leq T_a \leq 40^{\circ}\text{C}$)

Conditions of Certification:

When fitted with the transient option, the apparatus is not capable of withstanding the 500V electrical strength test as defined in Clause 8 of IEC 60079-15: 1987. This must be taken into account during installation.

Dimensional Drawings

Exploded View of the Rosemount 3095

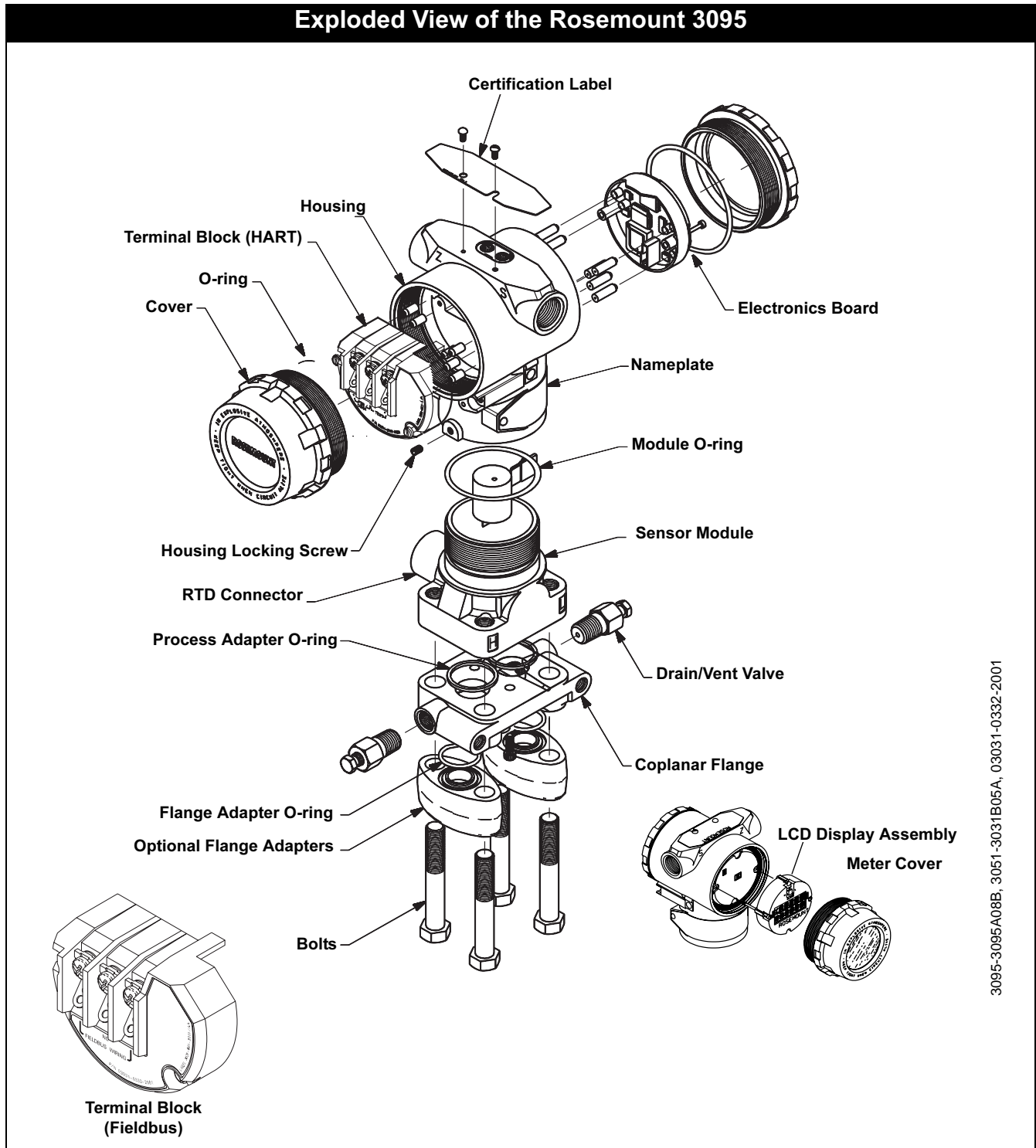

3095-3095A08B, 3051-3031B05A, 03031-0332-2001

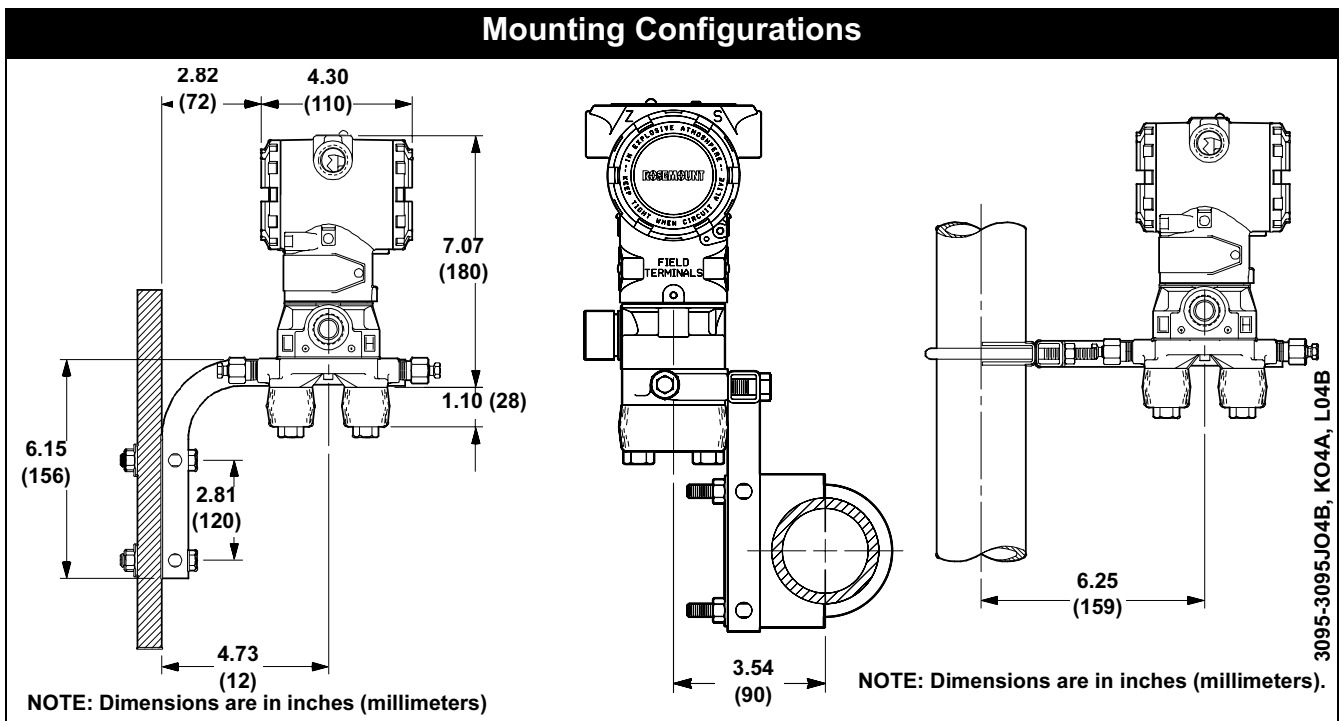
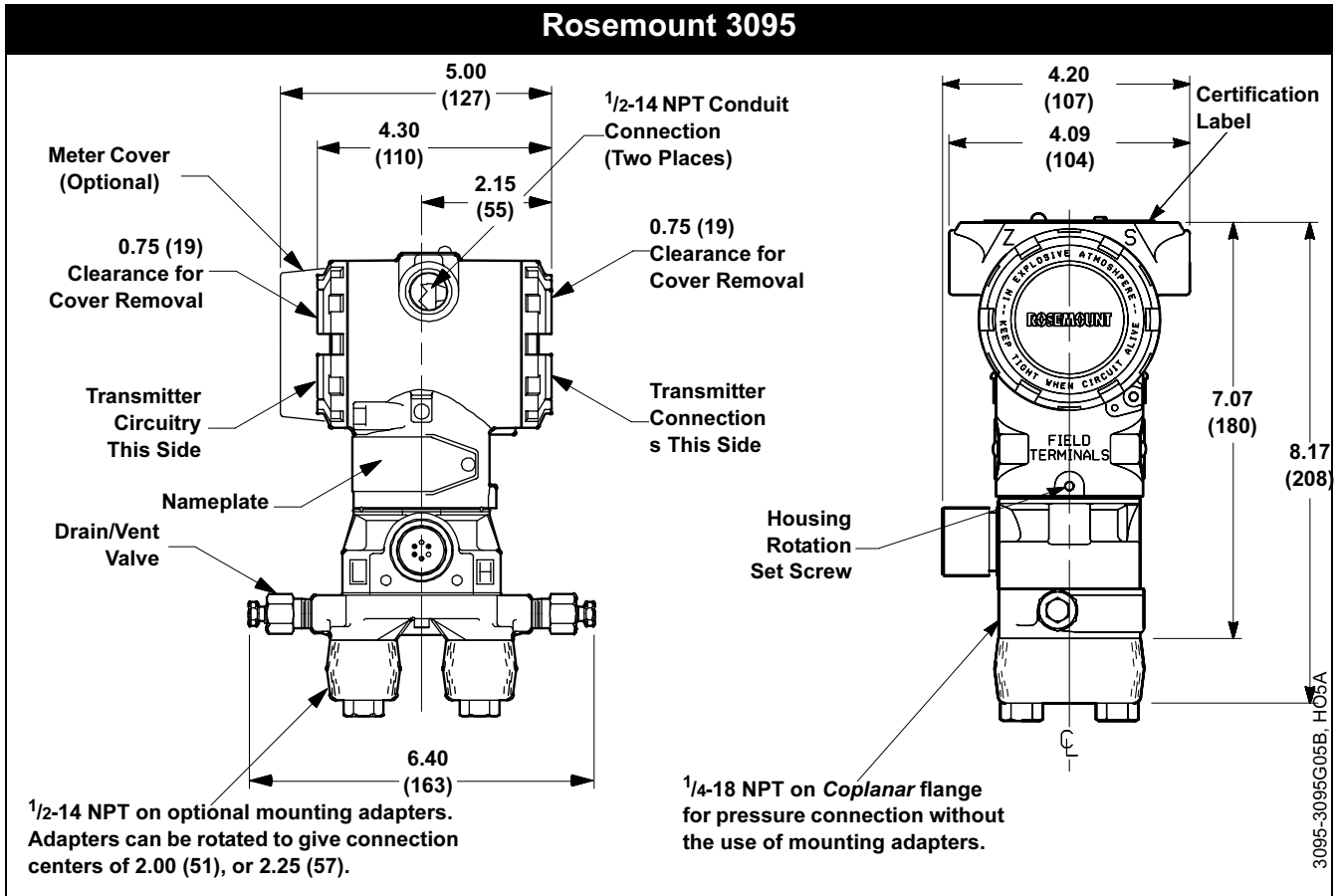

Rosemount 3095 MultiVariable

Ordering Information

Model	Product Description	
3095M	<i>MultiVariable</i> Mass Flow Transmitter	
Code	Output	
A	4–20 mA with digital signal based on HART protocol	
V	FOUNDATION™ fieldbus protocol	
Code	Differential Pressure Range	
1 ⁽¹⁾	0–0.5 to 0–25 inH ₂ O (0–1,25 to 0–62,3 mbar)	
2	0–2.5 to 0–250 inH ₂ O (0–6,22 to 0–622,7 mbar)	
3	0–10 to 0–1000 inH ₂ O (0–0,0249 to 0–2,49 bar)	
Code	Static Pressure Ranges	
3	0.5-8 to 0.5–800 psia (3,447–55,16 to 3,447–5516 kPa)	
4	0.5-36.26 to 0.5–3626 psia (3,447-250 to 3,447–25000 kPa)	
C	0-8 to 0-800 psig (0–55,16 to 0–5516 kPa)	
D	0-36.26 to 0-3626 psig (0-250 to 0–25000 kPa)	
Code	Isolator Material	Fill Fluid
A	316L SST	silicone
B ⁽²⁾	<i>Hastelloy C-276</i>	silicone
J ⁽³⁾	316L SST	inert
K ⁽²⁾⁽³⁾	<i>Hastelloy C-276</i>	inert
Code	Flange Style	Material
A	<i>Coplanar</i>	CS
B	<i>Coplanar</i>	SST
C	<i>Coplanar</i>	<i>Hastelloy C</i>
F ⁽⁴⁾	<i>Coplanar</i>	SST, non-vented
J	DIN compliant traditional flange, SST 10 mm adapter/manifold bolting	SST, ⁷ / ₁₆ — 20 Bolting
0	None (required for option code S3 or S5)	
Code	Drain/Vent Material	
A	SST	
C ⁽²⁾	<i>Hastelloy C</i>	
0	None (required for option code S3 or S5)	
Code	O-ring	
1	Glass-filled TFE	
Code	Process Temperature Input (RTD ordered separately)	
0	Fixed process temperature (no cable)	
1	RTD Input with 12 ft. (3,66 m) of Shielded cable (intended for use with conduit)	
2	RTD Input with 24 ft. (7,32 m) of Shielded cable (intended for use with conduit)	
7	RTD Input with 75 ft. (22,86 m) of Shielded cable (intended for use with conduit)	
6	RTD Input with 4 ft. (1,22 m) of Armored, Shielded cable	
3	RTD Input with 12 ft. (3,66 m) of Armored, Shielded cable	
4	RTD Input with 24 ft. (7,32 m) of Armored, Shielded cable	
5 ⁽⁵⁾	RTD Input with 21 in. (53 cm) of Armored, Shielded cable	
8	RTD Input with 75 ft. (22,86 m) of Armored, Shielded cable	
A	RTD Input with 12 ft. (3,66 m) of ATEX Flameproof cable	
B	RTD Input with 24 ft. (7,32 m) of ATEX Flameproof cable	
C	RTD Input with 75 ft. (22,86 m) of ATEX Flameproof cable	
D ⁽⁵⁾	RTD Input with 21 in. (53 cm) of ATEX Flameproof cable (typically ordered with Approval Code H)	
Code	Transmitter Housing Material	Conduit Entry Size
A	Polyurethane-covered aluminum	½–14 NPT
B	Polyurethane-covered aluminum	M20 × 1.5 (CM20)
C	Polyurethane-covered aluminum	PG 13.5
J	SST	½–14 NPT
K	SST	M20 × 1.5 (CM20)
L	SST	PG 13.5
Code	Terminal Block	
A	Standard	
B	With integral transient protection	

Product Data Sheet

00813-0100-4716, Rev KA

Catalog 2006 - 2007

Rosemount 3095 MultiVariable

Code	Display
0	None
1	LCD Display
Code	Bracket
0	None
1	<i>Coplanar</i> SST flange bracket for 2-in. pipe or panel mount, SST bolts
2	Traditional Flange Bracket for 2" Pipe Mounting, CS Bolts
3	Traditional Flange Bracket for panel Mounting, CS Bolts
4	Traditional Flange Flat Bracket for 2" Pipe Mounting, CS Bolts
5	Traditional Flange Bracket for 2" Pipe Mounting, 300-Series, SST Bolts
6	Traditional Flange Bracket for Panel Mounting, 300-Series, SST Bolts
7	Traditional Flange Flat Bracket for 2" Pipe Mounting, 300-Series, SST Bolts
8	SST Traditional Flange Bracket for 2" Pipe Mounting, 300-Series, SST Bolts
9	SST Traditional Flange Flat Bracket for 2" Pipe Mounting, 300-Series, SST Bolts
Code	Bolts
0	CS bolts
1	Austenitic 316 SST bolts
N	None (Required for Option Code S3 or S5)
Code	Product Certifications
0	None
A	FM Explosion-proof
B	FM Explosion-proof, Intrinsically Safe, Non-Incendive (combination of A and J)
J	FM Intrinsically Safe
V	FM FISCO Intrinsically Safe; for FOUNDATION fieldbus protocol only
K	CSA Intrinsically Safe
C	CSA Explosion-proof
D	CSA Explosion-proof, Intrinsically Safe, Non-Incendive (combination of C and K)
W	CSA FISCO Intrinsically Safe; for FOUNDATION fieldbus protocol only
F	ATEX Intrinsically Safe
G	ATEX Type n
H	ATEX Flame-proof
L	ATEX Flame-proof, Intrinsically Safe, Type n, Dust (combination of F, G, H, and P)
P	ATEX Dust
T	ATEX FISCO Intrinsically Safe; for FOUNDATION fieldbus protocol only
6	ATEX FISCO Flame-proof Intrinsically Safe, Type n, Dust
Y	IECEX FISCO Intrinsically Safe
4 ⁽⁶⁾	IECEX Intrinsically Safe
5 ⁽⁶⁾	IECEX Type n
N	SAA Flame-proof, Intrinsically Safe, Type n
R	JIS Flame-proof
Code	Engineered Measurement Solution (EMS)
B ⁽⁷⁾	Fully Compensated Mass Flow and Measured Variables (DP, P, and T) with HART or FOUNDATION fieldbus.
V	Process Variable Measurement (DP, P and T) only for FOUNDATION fieldbus protocol

Rosemount 3095 MultiVariable

Code	Options
	Performance Class
U3 ⁽⁸⁾	Ultra for Flow: $\pm 0.05\%$ DP reading accuracy, up to 100:1 rangedown, 10 year stability, limited 12 year warranty
	PlantWeb Control Functionality
A01 ⁽⁹⁾	FOUNDATION fieldbus Advanced Control Function Block Suite
	Custom Configuration
C2	Custom Flow Configuration (Requires completed Configuration Data Sheet)
	Flange Adapter
DF ⁽¹⁰⁾	Flange Adapters — Adapter Type Determined by Selected Flange Material: Plated CS, SST, <i>Hastelloy C</i>
	Integral Manifold
S5	Assemble to Rosemount 305 Integral Manifold (Requires integral manifold model number – see 00813-0100-4733)
S6	Assemble to Rosemount 309 Hookups (Required traditional Flange Style Options J, K, or L)
	Cleaning
P2	Cleaning for Special Services
	Material Traceability Certification
Q8 ⁽¹¹⁾	Material Inspection Certificate per EN 10204 3.1B
	Calibration Data Sheet
Q4	Inspection Certificate for Calibration Data
	Hydrostatic Testing
P1	Hydrostatic Testing with certificate
	Primary Elements
S3	Assemble to Rosemount 405 Compact Orifice (requires compact orifice model number, see 00813-0100-4810)
S4 ⁽¹²⁾	Assemble to Rosemount <i>Annubar</i> Averaging Pitot Tubes or Rosemount 1195 Integral Orifice Plate (requires corresponding model number, see 00813-0100-4809, 00813-0100-4760, or 00813-0100-4686)
	Surface Finish Certification
Q16	Surface Finish Certification
Typical Model Number 3095M A 2 3 A A A 1 3 A B 0 1 1 0 B	

- (1) Available only with 3 or C sensor modules and A 316L SST/silicone, Isolator/Fill Fluid option.
- (2) Materials of Construction comply with metallurgical requirements highlighted within NACE MR0175/ISO 15156 for sour oil field production environments. Environmental limits apply to certain materials. Consult latest standard for details. Selected materials also conform to NACE MR0103 for sour refining environments.
- (3) Only available with C or D Gage Sensor Modules.
- (4) Requires that Drain/Vent Material Code 0 (none).
- (5) For use with Annubars with integral RTDs.
- (6) Available with FOUNDATION fieldbus protocol only.
- (7) Requires Rosemount 3095 Engineering Software Assistant to configure mass flow.
- (8) Ultra for Flow applicable for HART protocol, DP ranges 2 and 3 with SST isolator material and silicone fill fluid options only.
- (9) Function Blocks include: Arithmetic, Integrator, Analog Output, Signal Characterizer, Control Selector, and Output Selector.
- (10) Not available with assembly to Rosemount 1195 Integral Orifice Option Code S4.
- (11) This option is available for the sensor module housing, Coplanar and Coplanar flange adapters.
- (12) With a primary element installed, the maximum operating pressure will be the lesser of either the transmitter or the primary element.

Product Data Sheet

00813-0100-4716, Rev KA
Catalog 2006 - 2007

Rosemount 3095 MultiVariable

OPTIONS

Standard Configuration

Unless otherwise specified, transmitter is shipped as follows:

Engineering units:

Differential	inH ₂ O (Range 2)
Absolute/gage	psi (all ranges)
Output:	Specified model code option
Flange type:	Specified model code option
Flange material:	Specified model code option
O-ring material:	Specified model code option
Drain/vent:	Specified model code option
Flow Configuration Parameters:	Factory default
Software tag:	(Blank)

In addition, transmitter is shipped as follows:

- The three process variables are digitally trimmed to the specified upper and lower range values.
- For Mass Flow and Measured Variables (EMS Code B), process variable output order is set to Flow, DP, AP/GP, PT.
- Flow is configured to measure air via ASME Orifice: Flange Tap, with a primary element minimum diameter of 0.5 in. (SST material), meter tube diameter of 2 in. (carbon steel material), flow range configured from 0–8,262 SCFH, 10–100 psia operating pressure range, and 50–100 °F operating temperature range.

Custom Configuration (Option Code C2)

If Option Code C2 is ordered, the custom flow configuration parameters are specified in addition to the standard configuration parameters. (See page 19 for HART protocol or page 26 for FOUNDATION Fieldbus protocol)

Fixed Process Temperature (Option Code 0)

If Process Temperature Input (option code 0) is ordered, the fixed process temperature is set to 68 °F unless specified during order entry (HART protocol only).

Tagging

Three customer tagging options are available:

- Standard SST tag is wired to the transmitter. Tag character height is 0.125 in. (3.18 mm), 85 characters maximum.
- Tag may be permanently stamped on transmitter nameplate upon request. Tag character height is 0.0625 in. (1.59 mm), 65 characters maximum.
- Tag may be stored in transmitter memory.
- Software tag (8 characters maximum HART protocol; 32 characters maximum FOUNDATION fieldbus protocol) is left blank unless specified.

Additional Information

Rosemount transmitters are available as fully assembled and factory calibrated flowmeters. Flowmeter Product Data Sheets are listed below:

- *Annubar* Flowmeter Series: 00813-0100-4809
Rosemount 3051SFA *ProBar*
Rosemount 3095MFA Mass *ProBar*
Rosemount 485 *Annubar* Primary Element
- *Proplate* Flowmeter Series: 00813-0100-4686
Rosemount 3051SFP *Proplate*
Rosemount 3095MFP Mass *Proplate*
Rosemount 1195 Integral Orifice Primary Element
- Compact Orifice Flowmeter Series: 00813-0100-4810
Rosemount 3051SFC Flowmeter
Rosemount 3095MFC Mass Flowmeter
Rosemount 405 Compact Orifice Primary
- Orifice Plate Primary Element Systems: 00813-0100-4792
Rosemount 1495 Orifice Plate
Rosemount 1595 Conditioning Orifice Plate 00813-0100-4828
Rosemount 1496 Flange Union
Rosemount 1497 Meter Section

Optional Rosemount 305 Integral Manifolds

Rosemount 3095 Transmitter and 305AC (305BC) Integral Manifold are fully assembled, calibrated, and seal tested by the factory. Refer to PDS 00813-0100-4733 for additional information.

Temperature Sensors and Assemblies

Rosemount offers many types of temperature sensors and assemblies.

ACCESSORIES

Rosemount 333 HART *Tri-Loop*™ HART-to-Analog Signal Converter

The Rosemount 333 HART *Tri-Loop* can be installed with the 3095 without disrupting existing device wiring. The 333 HART *Tri-Loop* provides up to three additional analog outputs for process monitoring or control without additional pipe penetrations.

The HART *Tri-Loop* accepts the 3095 digital signal and converts it to three independent isolated 4–20 mA analog signals. Any of the 3095 process variables (DP, AP, GP, PT, or flow) can be provided via the 333 HART *Tri-Loop*.

Rosemount 333 HART *Tri-Loop*

Model	Product Description
333	HART <i>Tri-Loop</i> (standard configuration)
Code	Alarm Option
U	High Alarm
D	Low Alarm
Code	Options
C2	Custom Configuration. Requires a completed Configuration Data Sheet (00806-0100-4754)

Typical Model Number: **333 U**

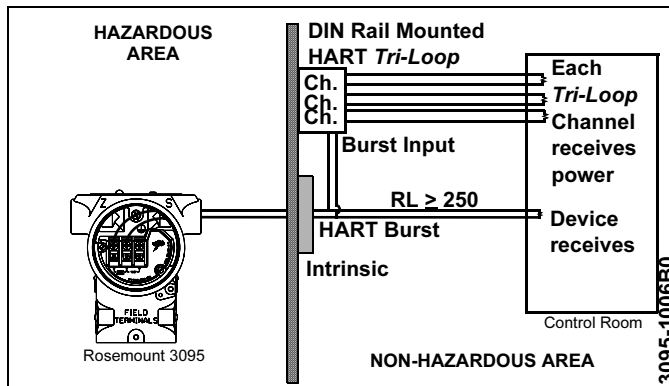

Accessories

Item Description	Part Number
Serial Port HART Modem and Cables Only	03095-5105-0001
USB Port HART Modem and Cables Only ⁽¹⁾	03095-5105-0002
FOUNDATION fieldbus PCM-CIA Interface Card and Cables	03095-5108-0001

⁽¹⁾ Supported by Snap-On EA with AMS Device Manager version 6.2 or higher.

Rosemount 3095 Engineering Assistant (EA) Software Packages

The Rosemount 3095 Engineering Assistant software supports mass flow configuration for both HART and FOUNDATION fieldbus protocols. The package is available with or without protocol-specific modem and connecting cables. All configurations are packaged separately.

For best performance of the EA Software, the following computer hardware and software is recommended:

- Pentium, 800MHz personal computer or above
- 512 MB RAM
- 350 MB of available hard disk space
- Mouse or other pointing device
- Color computer display
- Microsoft® Windows™ NT, 2000 or XP

3095 Engineering Assistant Software Package

Code	Product Description
EA	Engineering Assistant Software program
Code	Diskette Type
2 ⁽¹⁾	EA Software Rev. 5, CD-ROM (includes HART <i>Tri-Loop</i> Configurator Software)
Code	Language
E	English
Code	Modem and Connecting Cables
O	None
H	Serial Port HART Modem and Cables
C	FOUNDATION fieldbus PCM-CIA Interface Card and Cables
Code	Operating Software
N	EA Rev. 5
Code	License
1	Single PC license
2	Site license
Typical Model Number: EA 2 E O N 1	

⁽¹⁾ Revisions of EA - HART 5.3, 5.4, and 5.5 supports Windows NT, 2000, or XP and upgrades only on Windows 98. EA-FOUNDATION Fieldbus supports Windows 2000 and XP.