

Two-wire Radar Level Transmitter

The Rosemount 5400 Series is a 2-wire radar level transmitter designed for outstanding performance in a wide range of applications and process conditions. The 5400 Series consists of two models, 5401 (~6 GHz) and 5402 (~26 GHz). Each can be equipped with a wide range of antennas for maximum flexibility.

- *Excellent measurement reliability due to dual signal transmitters and receivers - Dual Port Technology*
- *The transmitter waveguide is less susceptible to coating with the Condensation Resistant Antenna*
- *Reduced echoes from obstacles / tank walls due to Circular Polarization*
- *Easy configuration and “Measure-and-Learn” support in Rosemount Radar Master*
- *Advanced PlantWeb® functionality*



Content

“Radar Economics™ – Innovative Measurement Technologies for a Better Bottom Line”	2
“Reliable Measurements through Advanced Surface Tracking Capability”	4
“System Integration”	5
“Rosemount 5400 Series Transmitter”	7
“Measuring Range”	9
“Best Practices for Mounting the Transmitter”	10
“Specifications”	12
“Product Certificates”	16
“Dimensional Drawings”	17
“Ordering Information”	20
“Application & Configuration Data Sheet”	24



Rosemount 5400 Series

Radar Echonomics™ – Innovative Measurement Technologies for a Better Bottom Line

The Rosemount 5400 Series is a pulsed 2-wire non-contacting radar level transmitter developed to improve profitability in your process plant. It utilizes the Radar Echonomics™ concept, adding value to your plant by processing the radar signals optimally to secure reliable measurement.

Radar Echonomics™ combines peak performance in three fundamental areas: **Echosensitivity™** – the skill to detect weak radar echoes in a noisy signal environment, **Echodynamics™** – the skill to handle weak and strong radar echoes simultaneously, and **Echologics™** – the intelligence to tell the true echo from the false. These skills, and the ability to use them innovatively, are based on many years of expertise and experience.

The 5400 Series transmitter is used for level measurements on liquids and slurries with various temperatures, pressures and vapor gas mixtures. Due to its advanced surface tracking capability, the transmitter can detect and evaluate all echoes within the tank.

Rosemount 5400 Series is easily configured for a wide range of applications and process conditions. In addition, it incorporates advanced signal processing and smart echo tracking features.

MEASUREMENT PRINCIPLE

The level of the liquid is measured by short radar pulses, which are transmitted from the antenna at the tank top towards the liquid.

When a radar pulse reaches a media with a different dielectric constant, part of the energy is reflected back to the transmitter. The time difference between the transmitted and the reflected pulse is proportional to the distance, from which the level is calculated.

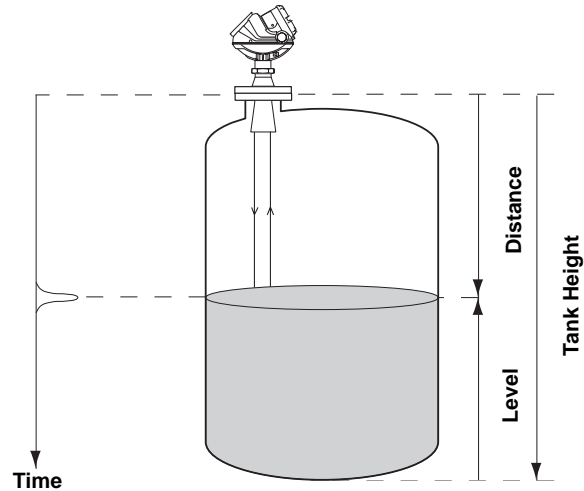

MODELS

The 5400 Series consists of two models:

- Rosemount 5401, Low Frequency Transmitter (~ 6 GHz).
- Rosemount 5402, High Frequency Transmitter (~ 26 GHz).

The availability of two frequencies allows the user to choose the model that will best fit the application.

Use 5401 in applications with turbulence, heavy vapors, foam or where there is a risk for deposits on the antenna.

Use 5402 with its more narrow radar beam in installations that have tall or narrow nozzles, where the nozzle is close to the tank wall or to avoid disturbing objects in the tank.

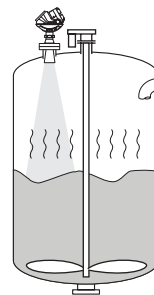

The 5401 transmitter is an ideal choice for turbulent tanks.

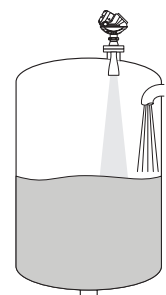

The 5402 transmitter with its narrow radar beam can be used even if the nozzle location is not optimal.

APPLICATION EXAMPLES FOR THE 5400 SERIES RADAR LEVEL TRANSMITTER

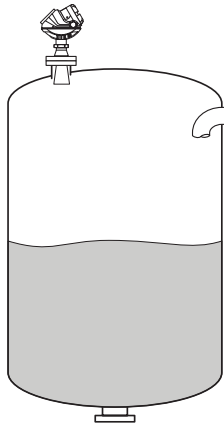

Storage / Buffer Tanks

The 5400 Series transmitters are suitable for storage / buffer tanks and also for tanks with narrow nozzle openings. Typical Storage and Buffer tanks have calm or slightly turbulent product surface.

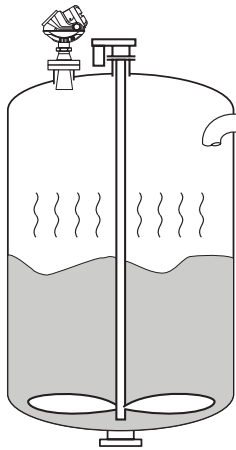

Process Tanks

High surface tracking capability enables the transmitter to handle tough process applications. Process tanks can be turbulent due to agitators or inlets, and can also contain vaporous and foamy products.

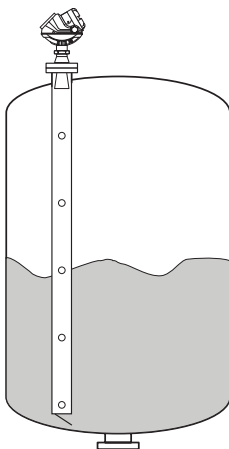

Pipes

Pipe mounting is recommended for extremely turbulent conditions, especially with low dielectric constant products. The pipe reduces the influence of foam and turbulence and increases surface reflection. It is also advantageous for liquified gas applications, where the surface sometimes is boiling.

For more information on which model and antenna to use for the applications above, see "Measuring Range" on page 9 or contact your local Emerson Process Management representative.

Rosemount 5400 Series

Reliable Measurements through Advanced Surface Tracking Capability

Different process conditions, such as the tank atmosphere, foam, turbulence and products with low dielectric constants, will all decrease the returned signal such that the radar transmitter may lose track of the surface. It is therefore important that the transmitter can detect very weak signals. The Rosemount 5400 Series transmitter incorporates several new innovations to get the best possible surface tracking capability. These features contribute to more reliable measurements and better performance when compared with standard 2-wire transmitters.

DUAL PORT TECHNOLOGY

Dual Port Technology means that there are two ports for transmitting and receiving signals, which reduces noise. Even if the returned signal is weak, the transmitter will still be able to reliably detect it. A transmitter with Dual Port Technology can receive 50% less reflected energy than a standard 2-wire transmitter and still have equal or better surface tracking capability. Standard 2-wire radar level transmitters only use one port on the microwave generation module for sending and receiving signals. This introduces significant losses in the microwave generation.

CONDENSATION RESISTANT ANTENNA

The tank seal is the part of the waveguide that protects the transmitter from the process atmosphere. Rosemount 5400 Series has a larger protective surface towards the tank, which makes the transmitter less sensitive to dirt and condensation.

Standard Transmitter

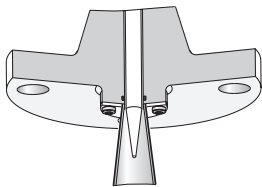

Rosemount 5402

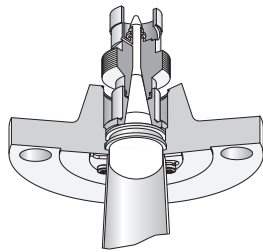

Rosemount 5400 Series transmitters are equipped with an enlarged PTFE tank seal to protect the antenna from contamination and condensation, an especially important feature for high frequency antennas.

CIRCULAR POLARIZATION

Standard radar transmitters utilize linear polarization resulting in greater influence from disturbing objects. The 5400 Series transmitter has circular polarization, which allows the transmitter to suppress even numbered signal bounces, thereby reducing echoes from tank walls / disturbing objects and increasing measurement reliability.

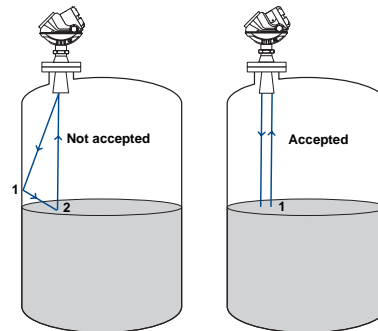

Circular polarization enables the transmitter to suppress even numbered signal bounces.

DYNAMIC RANGE OPTIMIZATION

Rosemount 5400 Series transmitters optimize the gain with respect to the tank height. The gain increases with the distance from the antenna, reaching its maximum at the tank bottom.

Maximum antenna gain is therefore achieved for all tanks independent of tank height.

This enables the ability to handle tough conditions everywhere in the tank, making the measurement more reliable compared with standard transmitters.

System Integration

The 5400 Series transmitter uses the same two wires for power supply and communication.

The transmitter is available with Intrinsically Safe⁽¹⁾ / Non-Incendive or Explosionproof / Flameproof approvals.

The input voltage for HART[®] is 16-42.4 V dc (16-30 V dc in IS applications, and 20-42.4 V dc in Explosionproof / Flameproof applications).

(1) *Fisco Intrinsic safety is available for Foundation™ fieldbus. See "Ordering Information" on page 20 and 22 for more information on available approvals.*

The input voltage for FOUNDATION™ fieldbus is 9-32 V dc (9-30 V dc in IS applications, and 16-32 V dc in Explosionproof / Flameproof applications).

For more information see "Product Certificates."

Measurement data is transmitted as an analog 4-20 mA signal with a superimposed digital HART[®] signal or FOUNDATION™ fieldbus signal.

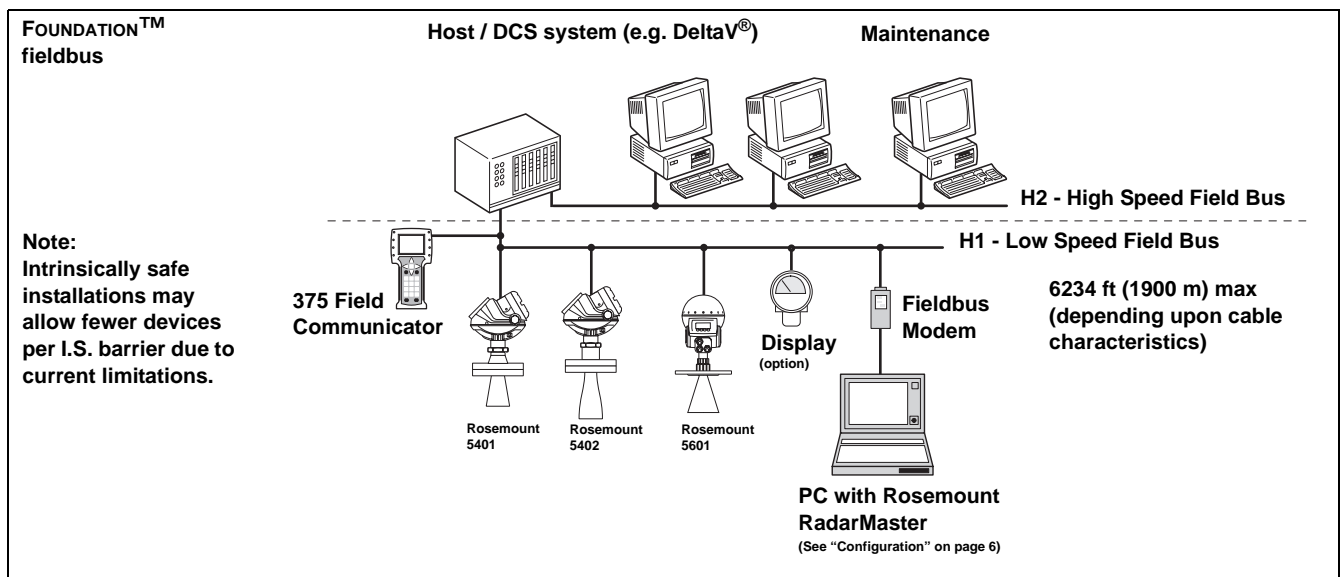
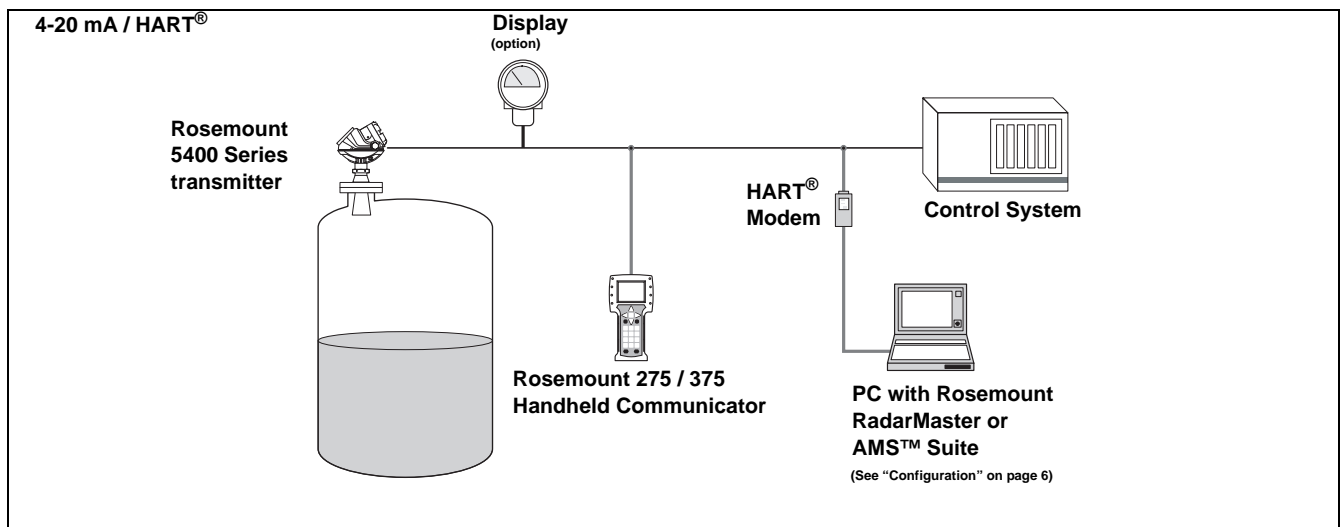

Rosemount 5400 Series

DISPLAY

Data can be read from the optional integral display or remotely by using the Rosemount 751 Field Signal Indicator (see Product Data Sheet, document number 00813-0100-4378) for 4-20 mA / HART® or the Rosemount 752 Remote Indicator for FOUNDATION™ fieldbus (see Product Data Sheet, document number 00813-0100-4377).

TRANSMITTER VARIABLES

From one Rosemount 5400 Series radar level transmitter it is possible to receive information about Level, Distance, Volume, Signal Strength, Level Rate, Analog Output Current, % of Range, and Internal Temperature.

CONFIGURATION

Basic configuration can easily be done either with Rosemount RadarMaster, a Rosemount 275/375 Handheld Communicator, the AMS™ Suite, DeltaV® or any other DD (Device Description) compatible host system. For advanced configuration features, RadarMaster is required.

RadarMaster is a user-friendly, Windows based software package that provides easy configuration and service. A wizard guides the user to enter the required parameters for a basic configuration. "Measure & Learn" functionality is accessed through RadarMaster. It enables automatic suggestion of threshold and disturbance echo settings, thereby making tough applications easy to configure. RadarMaster also includes waveform plots, off-line configuration, logging and extensive on-line help.

For 4-20 mA or HART®, a HART® modem is required for communication between the transmitter and RadarMaster (part number 03300-7004-0001 for RS232 and 03300-7004-0002 for USB interface).

For FOUNDATION™ fieldbus devices, RadarMaster is connected to the fieldbus segment via the fieldbus modem (part number 03095-5108-0001 for PCMCIA). For more information, see the 5400 FOUNDATION™ fieldbus Reference Manual (document number 00809-0100-4032) or consult factory.

Rosemount 5400 transmitters support PlantWeb® Alerts.

By filling in the Configuration Data Sheet (CDS), it is possible to order a pre-configured transmitter.



The integral display is easily configured with Rosemount RadarMaster or the Rosemount 275/375 Handheld Communicator. The user can choose which variable to display or if toggling between different variables should be applied.

ADVANCED PLANTWEB® FUNCTIONALITY



The Rosemount 5400 Series transmitter powers PlantWeb® through innovative measurement technologies and advanced diagnostics that provide higher reliability, easier configuration, reduced process downtime, lower installation and operating costs for a better bottom line.

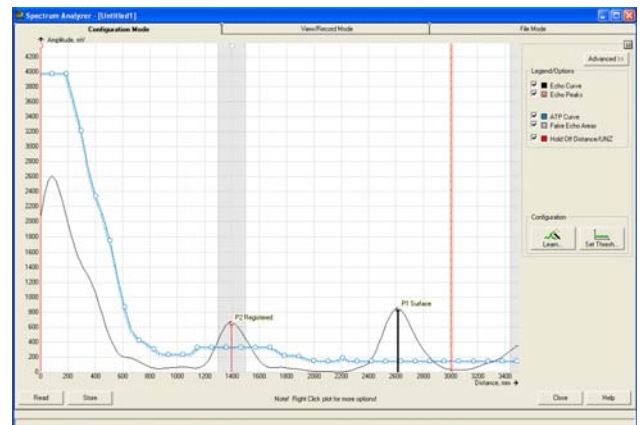

With Rosemount RadarMaster, a noise threshold curve and false echo registration can automatically be created by clicking the Learn button.

Rosemount 5400 Series Transmitter

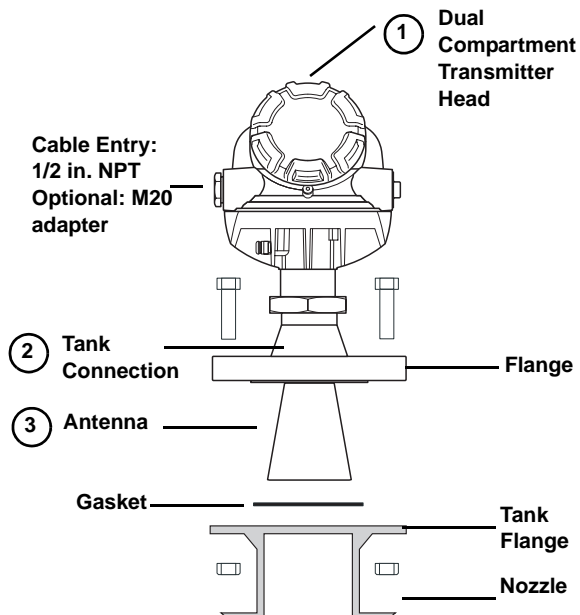

A Rosemount 5400 Series transmitter consists of a transmitter head, a tank connection and an antenna. The different parts are pre-mounted in factory so the Rosemount 5400 is delivered as a single assembly to be installed directly on the tank nozzle.

The tank connection and the antenna are the only parts in contact with the tank atmosphere.

TRANSMITTER HEAD ①

There is one low-frequency (5401) and one high-frequency (5402) variant of the head, which are not interchangeable.

The dual compartment die-cast aluminium transmitter head has electronics and terminals in separate compartments for increased moisture resistance. It has two entries for conduit/cable connections. The 5400 Series is available with a 1/2 in. NPT cable entry or an M20 adapter as an option. See "Ordering Information" on page 20 and 22.

The head can be removed without opening the tank, which improves safety and facilitates service. When installing, it is also possible to rotate the head in any direction.

TANK CONNECTION ②

The tank connection consists of a Tank Seal, and a flange (ANSI and EN (DIN)) or thread (NPT).

Flange rating follows standard ANSI B 16.5 and EN 1092-1.

For more information on temperature and pressure, see "Temperature and Pressure Ratings" on page 14.

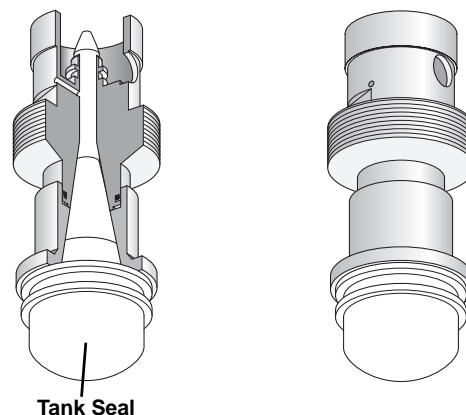

Rosemount 5402 cone antenna tank connection with enlarged tank seal protects the transmitter from dirt and condensation.

Rosemount 5400 Series

ANTENNAS ③

The Rosemount 5400 Series Radar Level transmitters are equipped with high performance cone, rod and process seal antennas in various sizes and materials. The antenna program differs depending on transmitter frequency (5401 or 5402).

The Cone antenna is the best choice for a broad range of applications and it is suitable for free propagation as well as pipe installations.

The cone antenna is available in 316 / 316 L SST (EN 1.4404), Hastelloy® C-276 (UNS N10276) or Monel® 400 (UNS N04400) for both 5401 and 5402. Hastelloy®, and Monel® antennas are designed with a protective plate, to prevent the flange from being exposed to the tank atmosphere.

The Process Seal antenna is available for the 5402. The dish made of PTFE seals off the cone shaped antenna from the tank atmosphere making it ideal for hygienic and corrosive applications. It is also suitable for applications with heavy antenna condensation and build-up.

The Rod antenna is available for the 5401. The minimal dimensions make it suitable for tanks with small openings. It is available in two versions:

- All-PFA⁽¹⁾
- Stainless Steel + PFA⁽¹⁾

The PFA coating makes it especially well suited for hygienic applications and corrosive environments.

See "Ordering Information" on page 20 and 22, "Product Certificates" on page 16 and "Dimensional Drawings" on page 17 for details.



4-inch low frequency cone antenna (5401).

4-inch high frequency cone antenna (5402).



Process Seal antenna for Rosemount 5402.



Rod antenna for Rosemount 5401.

(1) PFA is a fluoropolymer with properties similar to PTFE.

Measuring Range

The measuring range depends on the microwave frequency, antenna size, the dielectric constant (ϵ_r) of the liquid, and process conditions. The higher the dielectric constant value, the stronger the reflection (see the following tables). The figures below are given as a guideline for optimum performance. For more information, contact your local Emerson Process Management office.

- A. Oil, gasoline or other hydrocarbons, and petrochemicals ($\epsilon_r = 1.9-4.0$).
- B. Alcohols, concentrated acids, organic solvents, oil/water mixtures, and acetone ($\epsilon_r = 4.0-10.0$).
- C. Conductive liquids, e.g. water based solutions, dilute acids, and alkalis ($\epsilon_r > 10.0$).

Rosemount 5401, Maximum Recommended Measuring Range, ft (m)

Low Frequency Antennas									
	Dielectric Constant								
	A	B	C	A	B	C	A	B	C
3-in. Cone ⁽¹⁾	NA	NA	NA	66 (20)	66 (20)	66 (20)	NA	NA	NA
4-in. Cone / Rod ⁽²⁾	20 (6)	33 (10)	43 (13)	66 (20)	66 (20)	66 (20)	9.9 (3)	16 (5)	23 (7)
6-in. Cone	33 (10)	49 (15)	66 (20)	66 (20)	66 (20)	66 (20)	16 (5)	23 (7)	30 (9)
8-in. Cone	49 (15)	66 (20)	98 (30)	66 (20)	66 (20)	98 (30)	23 (7)	30 (9)	36 (11)

(1) Pipe installations only. NA=not applicable.

(2) Pipe installations are not allowed with rod antennas.

Rosemount 5402, Maximum Recommended Measuring Range, ft (m)

High Frequency Antennas									
	Dielectric Constant								
	A	B	C	A	B	C	A	B	C
2-in. Cone / Process Seal ⁽¹⁾	16 (5)	33 (10)	49 (15)	66 (20)	66 (20)	66 (20)	6.6 (2)	9.8 (3)	13 (4)
3-in. Cone / Process Seal ⁽¹⁾	33 (10)	49 (15)	66 (20)	66 (20)	66 (20)	66 (20)	9.8 (3)	13 (4)	20 (6)
4-in. Cone / Process Seal ⁽¹⁾	49 (15)	66 (20)	98 (30)	66 (20)	66 (20)	98 (30)	13 (4)	20 (6)	26 (8)

(1) Pipe installations are not allowed with process seal antennas.

Rosemount 5400 Series

Best Practices for Mounting the Transmitter

The transmitter should be installed in locations where there is a clear and unobstructed view of the level surface (A):

- Install the transmitter off-center. (B)
- Disturbing objects and filling inlets creating turbulence should be kept at a distance, outside the signal beam (C). See tables in the right-hand column for beamwidth information.
- A bridle / still-pipe can be used to avoid disturbing objects, turbulence, and foam.

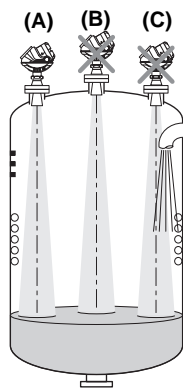

- Choose the largest possible antenna diameter for the installation. A larger antenna will concentrate the radar beam, and will be less susceptible to interference by obstructions. It also assures maximum antenna gain.
- The antenna is normally aligned vertically.
- For best measurement performance, the cone antenna should extend 0.4 inches (10 mm) below the nozzle or more (D).
- The flat tank wall can be located within the antenna beam angle as long as there is a minimum distance (E) from the transmitter to the tank wall (see pictures).

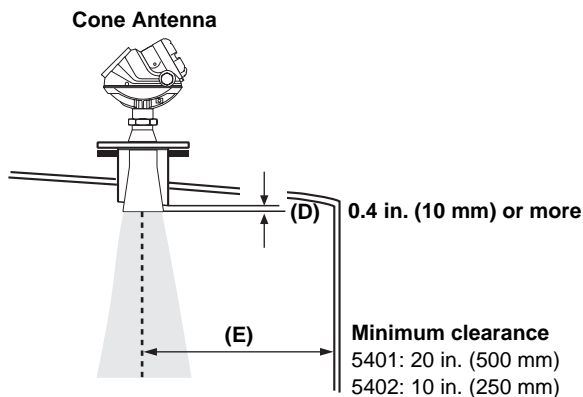

- The active part of the rod antenna must stick beneath the nozzle (F).

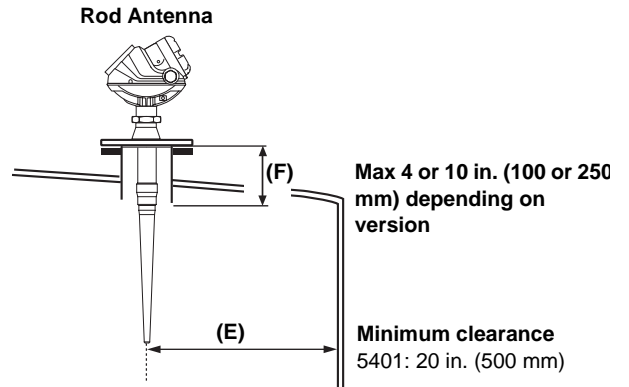

- The maximum height of the nozzle is 20 in. (500 mm) for the process seal antenna (G).

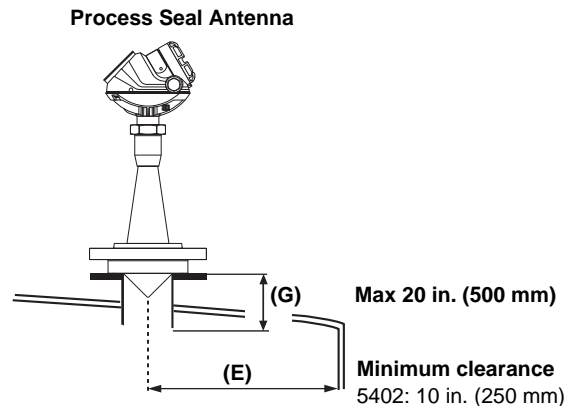

Product Data Sheet

00813-0100-4026, Rev EA

October 2005

Rosemount 5400 Series

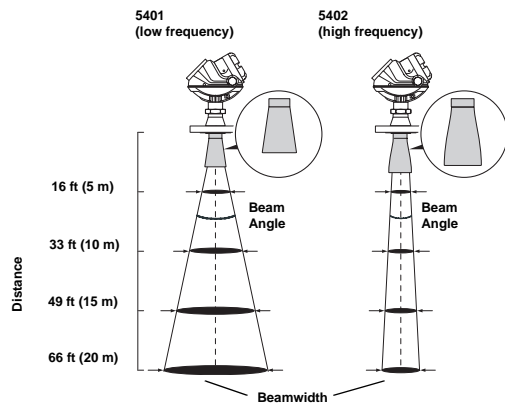

Comparison between the beam angle and beamwidth for the Rosemount 5401 (~6 GHz) and 5402 (~26 GHz) transmitters with antennas of the same size and type.

Beam Angle for Rosemount 5400 Series

Antenna Size	Beam Angle 5401	Beam Angle 5402
2-in. Cone / Process Seal ⁽¹⁾	–	19°
3-in. Cone / Process Seal ⁽¹⁾	(Pipe only)	14°
4-in. Cone / Process Seal ⁽¹⁾ , Rod ⁽²⁾	37°	9°
6-in. Cone	23°	-
8-in. Cone	17°	-

⁽¹⁾ Only with 5402.

⁽²⁾ Only with 5401.

Beamwidth at different distances from flange for 5401

Distance	Antenna		
	4-in. Cone / Rod	6-in. Cone	8-in. Cone
16 ft (5 m)	11.5 (3.5)	6.6 (2.0)	4.9 (1.5)
33 ft (10 m)	23.0 (7.0)	13.1 (4.0)	9.8 (3.0)
49 ft (15 m)	32.8 (10)	19.7 (6.0)	14.8 (4.5)
66 ft (20 m)	42.7 (13)	26.2 (8.0)	19.7 (6.0)

Beamwidth at different distances from flange for 5402

Distance	Antenna		
	2-in. Cone / Process Seal	3-in. Cone / Process Seal	4-in. Cone / Process Seal
16 ft (5 m)	4.9 (1.5)	3.3 (1.0)	3.3 (1.0)
33 ft (10 m)	9.8 (3.0)	6.6 (2.0)	4.9 (1.5)
49 ft (15 m)	14.8 (4.5)	9.8 (3.0)	8.2 (2.5)
66 ft (20 m)	19.7 (6.0)	13.1 (4.0)	9.8 (3.0)

For more information, see the Reference Manual (document number 00809-0100-4026).

Rosemount 5400 Series

Specifications

General	
Product	Rosemount 5400 Series Radar Level Transmitter
Measurement Principle	Pulsed, free propagating radar 5401: ~6 GHz 5402: ~26 GHz
Microwave Output Power	< 1 mW
Beam Angle	See table on page 10
Measuring Performance	
Measuring Range	98 ft (30 m) from flange
Instrument Accuracy at reference conditions ⁽¹⁾	5401: ± 0.4 in. (± 10 mm). 5402: ± 0.1 in. (± 3 mm).
Dead Zone ⁽²⁾	Cone antenna: 5.9 in. (150 mm) from antenna lower end. Rod antenna: 2.0 in. (50 mm) from antenna lower end. Process Seal antenna: Lowest value of 150 mm under antenna lower end and up to 50 mm from lower end of nozzle.
Near Zone Distance	Cone and Rod Antennas: 1.3 ft (0.4 m) from antenna lower end Process Seal Antenna: Lower end of nozzle
Near Zone Accuracy	5401: ± 1.2 in. (± 30 mm). 5402: ± 0.6 in. (± 15 mm) for all antennas except the 2-in. Process Seal, which has ± 1.2 in. (± 30 mm).accuracy.
Resolution	0.04 in. (1 mm)
Repeatability	± 0.04 in. (± 1 mm) at 16.4 ft (5 m) distance
Temperature Drift	0.05 %/10 K in temperature range -40°F to 176°F (-40°C to 80°C)
Update Interval	1 second
Max Level Rate	1.6 in./s (40 mm/s) as default, adjustable to 7.9 in./s (200 mm/s)
Display / Configuration / Communication	
Integral Display	5-digit integral display. The process variables listed below can be presented. If more than one variable is chosen, carousel toggling of data is used. The display also shows diagnostics and error information.
Output Variables	Level, Distance, Volume, Level Rate, Signal Strength, Internal Temperature, Analog Output Current ⁽³⁾ , and % of Range ⁽³⁾
Output Units	Level and Distance: ft, inch, m, cm or mm Volume: ft ³ , inch ³ , US gals, Imp gals, barrels, yd ³ , m ³ , or liters Level Rate: ft/s, m/s Temperature: °F, °C
Configuration Tools	HART®: Rosemount RadarMaster, Rosemount 275/375 Handheld Communicator, AMS Suite FOUNDATION™ fieldbus: Rosemount RadarMaster, 375 Handheld Communicator, DeltaV® or any other DD (Device Description) compatible host system
FOUNDATION™ fieldbus Blocks	Resource block, 3 Transducer blocks, 6 AI blocks, PID block, ISEL block, SGCR block, ARTH block, and OS block
FOUNDATION™ fieldbus Class (Basic or Link Master)	Link Master (LAS)
FOUNDATION™ fieldbus Block Execution Time	AI-block: 30 ms. PID-block: 40 ms. ARTH-, ISEL-, OSPL-block: 65 ms. CHAR-block: 75 ms
FOUNDATION™ fieldbus Instantiation	Yes (all activated)
Conforming FOUNDATION™ fieldbus	ITK 4.6
FOUNDATION™ fieldbus PlantWeb® Alert Support	Yes
Electric	
Power Supply	HART®: 16-42.4 V dc (16-30 V dc in IS applications, 20-42.4 Vdc in Explosionproof / Flameproof applications). FOUNDATION™ fieldbus: 9-32 V dc (9-30 V dc in IS applications, and 16-32 V dc in Explosionproof / Flameproof applications). FISCO, IS applications: 9-17.5 V dc.
Internal Power Consumption	< 50 mW in normal operation

Product Data Sheet

00813-0100-4026, Rev EA

October 2005

Rosemount 5400 Series

Electric, continued

Output	HART [®] 4-20 mA current loop or FOUNDATION [™] fieldbus
Signal on Alarm (configurable), HART [®]	Standard: Low=3.75 mA, High=21.75 mA Namur NE43: High=22.5 mA
Saturation Levels, HART [®]	Standard: Low=3.9 mA, High=20.8 mA Namur NE43: High=20.5 mA
IS Parameters	See "Product Certificates" on page 16
Cable Entry	1/2 in. NPT or optional M20x1.5 adapter
Output Cabling	24-12 AWG, twisted shielded pairs
Quiescent Current Draw (FOUNDATION [™] fieldbus)	21 mA

Mechanical

Antennas	See pages 8 and 20
Material Exposed to Tank Atmosphere	Cone Antenna <ul style="list-style-type: none">• 316 / 316 L SST (EN 1.4404) or Monel[®] 400 (UNS NO4400) or Hastelloy[®] C-276 (UNS N10276). Monel[®] and Hastelloy[®] antennas have a plate design.• PTFE fluoropolymer• O-ring material. Rod Antenna, Two versions <ul style="list-style-type: none">• All-PFA⁽⁴⁾ fluoropolymer• PFA⁽⁴⁾ fluoropolymer, 316 / 316 L SST (EN 1.4404) and O-ring material. Process Seal Antenna <ul style="list-style-type: none">• PTFE fluoropolymer• O-ring material <p>For more information, see pages 20 and 22.</p>
Housing / Enclosure	Polyurethane-covered Aluminum
Dimensions	See "Dimensional Drawings" on page 17
Weight, excl. flange and antenna	2.0 kg (4.4 lb)

Environment

Ambient Temperature	Non-Hazardous, HART [®] communication: -40°F to 176°F (-40°C to 80°C) ⁽⁵⁾ . IS/EEEx ia and XP/EEEx d, HART [®] communication: -40°F to 158°F (-40°C to 70°C) ⁽⁵⁾ . IS/EEEx ia and XP/EEEx d, FOUNDATION [™] fieldbus: -40°F to 140°F (-40°C to 60°C) ⁽⁶⁾ . LCD readable in: -4°F to 158°F (-20°C to 70°C).
Storage Temperature	-58°F to 194°F (-50°C to 90°C). LCD: -40°F to 185°F (-40°C to 85°C)
Process Temperature ⁽⁷⁾	See "Temperature and Pressure Ratings" on page 14
Process Pressure ⁽⁷⁾	See "Temperature and Pressure Ratings" on page 14
Humidity	0 - 100% Relative Humidity, non condensating
Factory Sealed	Yes
Ingress Protection	Type 4X, IP66, IP67
EU Directive compliance	CE mark, 93/68/EEC
Telecommunication (FCC and R&TTE) ⁽⁸⁾	FCC part 15C (1998) and R&TTE (EU directive 1999/5/EC)
Electromagnetic Compatibility	Emission and Immunity: EMC directive 89/336/EEC. EN61326-1:1997 incl. A1:1998 and A2:2001. NAMUR recommendations NE21.
Transient / Built-in Lightning Protection	EN61326, IEC 801-5, level 1 kV. T1 option: the transmitter complies with IEEE 587 Category B transient protection and IEEE 472 surge protection
Pressure Equipment Directive (PED)	97/23/EC

(1) Temperature: + 68 °F (20 °C).

Pressure: 14-15 psi (960-1060 mbar).

Humidity: 25-75 % RH.

Metal plate, no disturbing objects.

(2) Dead Zones are areas where measurements are not recommended.

(3) Not applicable for FOUNDATION[™] fieldbus.

(4) PFA is a fluoropolymer with properties similar to PTFE.

(5) Depends on O-ring selection. The maximum ambient temperature also depends on the process temperature: for every process temperature degree above 185°F (85°C), the maximum ambient temperature is reduced by 0.27°F (0.15°C).

(6) Depends on O-ring selection. The maximum ambient temperature also depends on the process temperature: for every process temperature degree above 185°F (85°C), the maximum ambient temperature is reduced by 0.54°F (0.3°C).

(7) Final rating depends on flange and O-ring selection. See "Temperature and Pressure Ratings" on page 14 and "Ordering Information" on page 20 and 22.

(8) The 5402 is authorized for use in tank-mounted applications, including metal tanks as well as concrete, plastic, glass and other non-conductive tanks.

Rosemount 5400 Series

TEMPERATURE AND PRESSURE RATINGS

The temperature/pressure rating depends on the design of the transmitter in combination with process seal O-ring, flange and gasket materials.

Transmitter

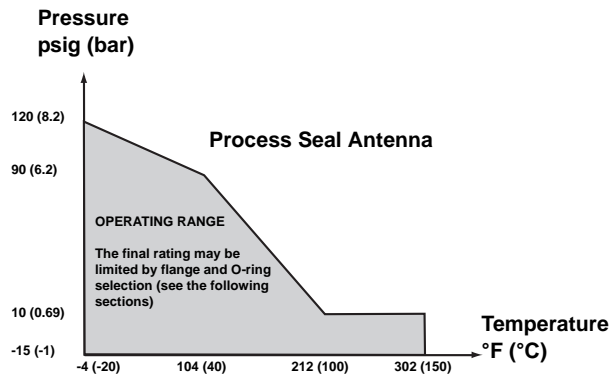
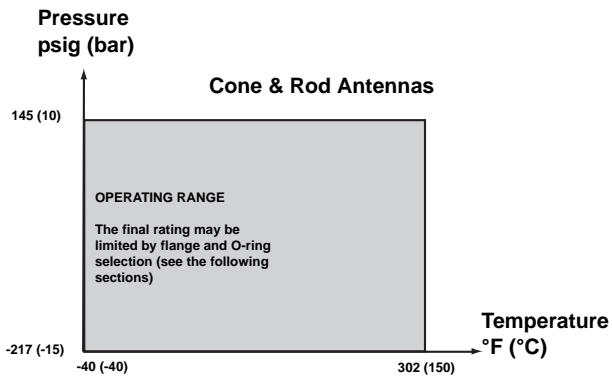

Process temperature and pressure diagram for Rosemount 5400 Series.

Temperature Restrictions due to O-ring Selection

The Tank Seal has an O-ring seal, which is selected depending on the specific temperature and product requirements. The following table⁽¹⁾ presents the applicable temperature ranges:

Tank seal with different O-ring materials	Min. Temperature °F (°C) in air	Max. Temperature °F (°C) in air
Viton®	-4 (-20)	302 (150)
Ethylene Propylene (EPDM)	-40 (-40)	302 (150)
Kalrez® 6375	5 (-15)	302 (150)
Buna-N	-40 (-40)	230 (110)

Pressure Restrictions due to Flange Selection

The maximum allowed pressure may also be limited by the flange rating. The 5400 Series flange has the same p/T rating as the corresponding blind flange:

ANSI: according to ANSI B16.5 Table 2-2.3.

EN: according to EN 1092-1 Table 18, material group 13E0.

(1) Not applicable for the all-PFA rod antennas (1R and 2R).

Product Data Sheet

00813-0100-4026, Rev EA

October 2005

Rosemount 5400 Series

LOAD LIMITATIONS

The Rosemount 275 / 375 Handheld Communicator requires a minimum load resistance of 250 Ohm within the loop in order to function properly. The maximum load resistance can be obtained from the following diagrams.

R: Maximum Load Resistance

U: External Power Supply Voltage

Non-Hazardous Installations

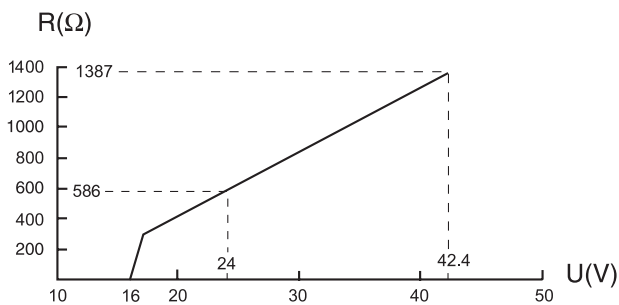

Intrinsically Safe Installations

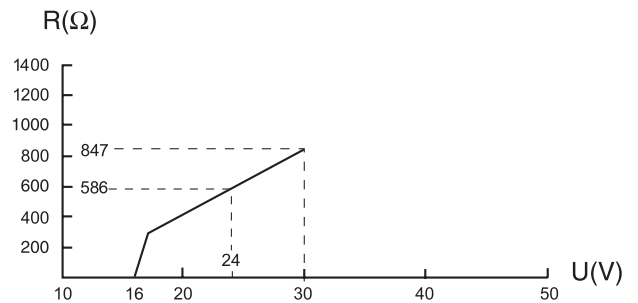

Explosionproof / Flameproof (EEx d) Installations

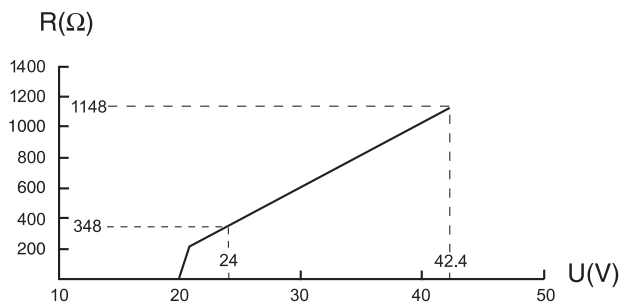

NOTE

For the EEx d case the diagram is only valid if the HART® load resistance is at the + side and if the - side is grounded, otherwise the load resistance value is limited to 435 Ohm.

Product Certificates

SAFETY NOTE AND SPECIAL CONDITIONS FOR SAFE USE (X-MARKING IN NEMKO ATEX CERTIFICATE)

The intrinsically safe circuits do not withstand the 500 V ac test as specified in EN 50020 clause 6.4.12.



Parts of the rod antenna and the process seal antenna are non-conducting and the area of the non-conducting part exceeds the maximum permissible areas for Group IIC according to EN 50014, clause 7.3 (20 cm²) and Category II 1G according to EN 50284, clause 4.4.3 (4 cm²). Therefore, when the antenna is used in a potentially explosive atmosphere, appropriate measures must be taken to prevent electrostatic discharge.

Impact and friction hazards need to be considered according to EN 50284, clause 4.3.1 when the transmitter and part of antennas exposed to the exterior atmosphere of the tank is made of light metal alloys, and used in Category II 1 G.

Factory Mutual (FM) Approvals

- E5⁽¹⁾ Explosion Proof for Class I, Div. 1, Groups B, C and D;
Dust Ignition Proof for Class II/III, Div. 1, Groups E, F and G;
With Intrinsically Safe connections to Class I, II, III, Div. 1, Groups B, C, D, E, F and G.
Temp. Code T4
Ambient temperature limits: -40°C to +70°C⁽²⁾.
Seal not required.
- I5⁽¹⁾ Intrinsically Safe for Class I, II, III, Div. 1, Groups A, B, C, D, E, F and G,
Class I, Zone 0, AEx ia IIC T4 when installed per Control Drawing: 9150079-905.
Non-Incendive Class I, Div. 2, Groups A, B, C and D;
Suitable for Class II, III, Div. 2, Groups F and G.
4-20 mA / HART[®] model: U_i=30 V dc, I_i=130 mA, P_i=1.0 W, C_i=7.26 nF, L_i=0 H.
FOUNDATION[™] fieldbus model: U_i=30 V dc, I_i=300 mA, P_i=1.3 W, C_i=0 nF, L_i=0 H.
FISCO model: U_i=17.5 V dc, I_i=380 mA, P_i=5.32 W, L_i=C_i=0.
Max operation:
4-20 mA / HART[®] model: 42.4 V, 25 mA,
FOUNDATION[™] fieldbus model: 32 V, 25 mA.
Temp. Code T4
Ambient temperature limits: -40°C to +70°C⁽²⁾

ATEX Approval Nemko 04ATEX1073X

- E1⁽¹⁾ Flameproof:
 II 1/2 GD T73°C⁽³⁾.
EEx iad IIC T4 (-40°C<T_a<+70°C⁽²⁾).
U_m=250 V
- I1⁽¹⁾ Intrinsically Safe:
 II 1 GD T73°C⁽³⁾.
EEx ia IIC T4 (-40°C<T_a<+70°C⁽²⁾).
4-20 mA / HART[®] model: U_i=30 V dc, I_i=130 mA, P_i=1.0 W, C_i=7.26 nF, L_i=0 H.
FOUNDATION[™] fieldbus model: U_i=30 V dc, I_i=300 mA, P_i=1.5 W, C_i=0 nF, L_i=0 H.
FISCO model: U_i=17.5 V dc, I_i=380 mA, P_i=5.32 W, L_i=C_i=0.
Installation Drawing: 9150079-907.

Canadian Standards Association (CSA) Approval

- E6⁽¹⁾ Explosionproof with internal Intrinsically Safe Circuits [Exia] Class I, Div. 1, Groups B, C and D;
Temp Code T4.
Class II, Div. 1 and 2, Groups E, F and G;
Class III, Div. 1
Ambient temperature limits -40°C to +70°C⁽²⁾
Factory sealed.
- I6⁽¹⁾ Intrinsically Safe Exia:
Class I, Div. 1, Groups A, B, C and D.
Temp Code T4.
4-20 mA / HART[®] model: U_i=30 V dc, I_i=130 mA, P_i=1.0 W, C_i=7.3 nF, L_i=0 H.
FOUNDATION[™] fieldbus model: U_i=30 V dc, I_i=300 mA, P_i=1.3 W, C_i=0 nF, L_i=0 H.
FISCO model: U_i=17.5 V dc, I_i=380 mA, P_i=5.32 W, L_i=C_i=0.
Installation Drawing: 9150079-906
Ambient temperature limits -40°C to +70°C⁽²⁾.

For more information on product certificates, refer to the Reference Manual (document number 00809-0100-4026).

(1) Ordering Information code for Product Certificates, see page 20.

(2) +60°C with FOUNDATION[™] fieldbus or FISCO option.

(3) +63°C with FOUNDATION[™] fieldbus or FISCO option.

Dimensional Drawings

All dimensions are in inches (mm).

ROSEMOUNT 5401 WITH CONE ANTENNA

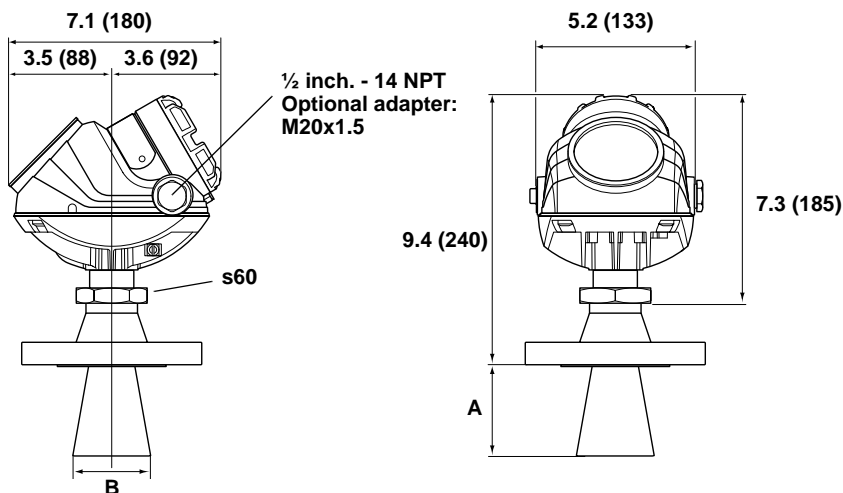

ROSEMOUNT 5402 WITH CONE ANTENNA

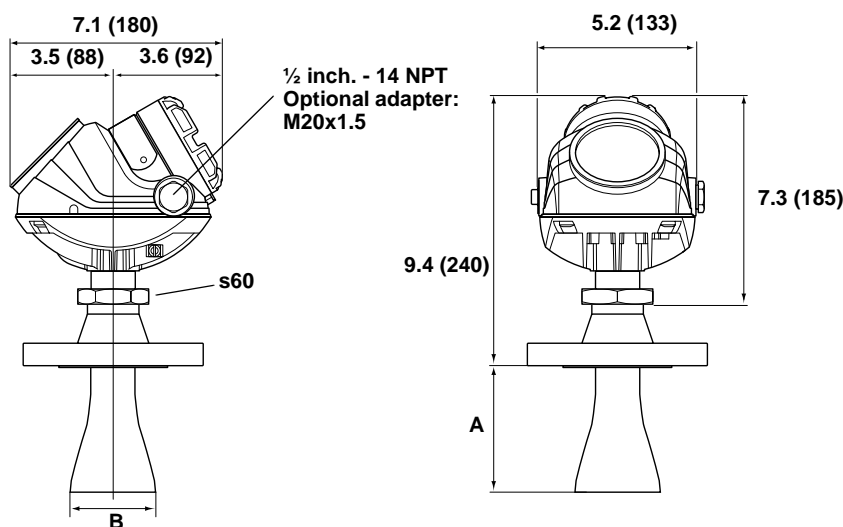

NOTE
 Hastelloy® and Monel® antennas
 have a plate design.

5401 Dimensions

Material	Cone size (inch)	A	B
SST, Hastelloy® and Monel®	3	3.3 (84)	2.6 (67)
	4	5.9 (150)	3.6 (92)
	6	7.3 (185)	5.5 (140)
	8	10.6 (270)	7.4 (188)

5402 Dimensions

Material	Cone size (inch)	A	B
SST	2	6.5 (165)	2.0 (50)
	3	5.9 (150)	2.6 (67)
	4	8.8 (225)	3.6 (92)
	Hastelloy® and Monel®	2	5.9 (150)
3		6.9 (175)	2.6 (67)
4		9.8 (250)	3.6 (92)

All dimensions are in inches (mm).

ROSEMOUNT 5400 SERIES WITH ROD ANTENNA

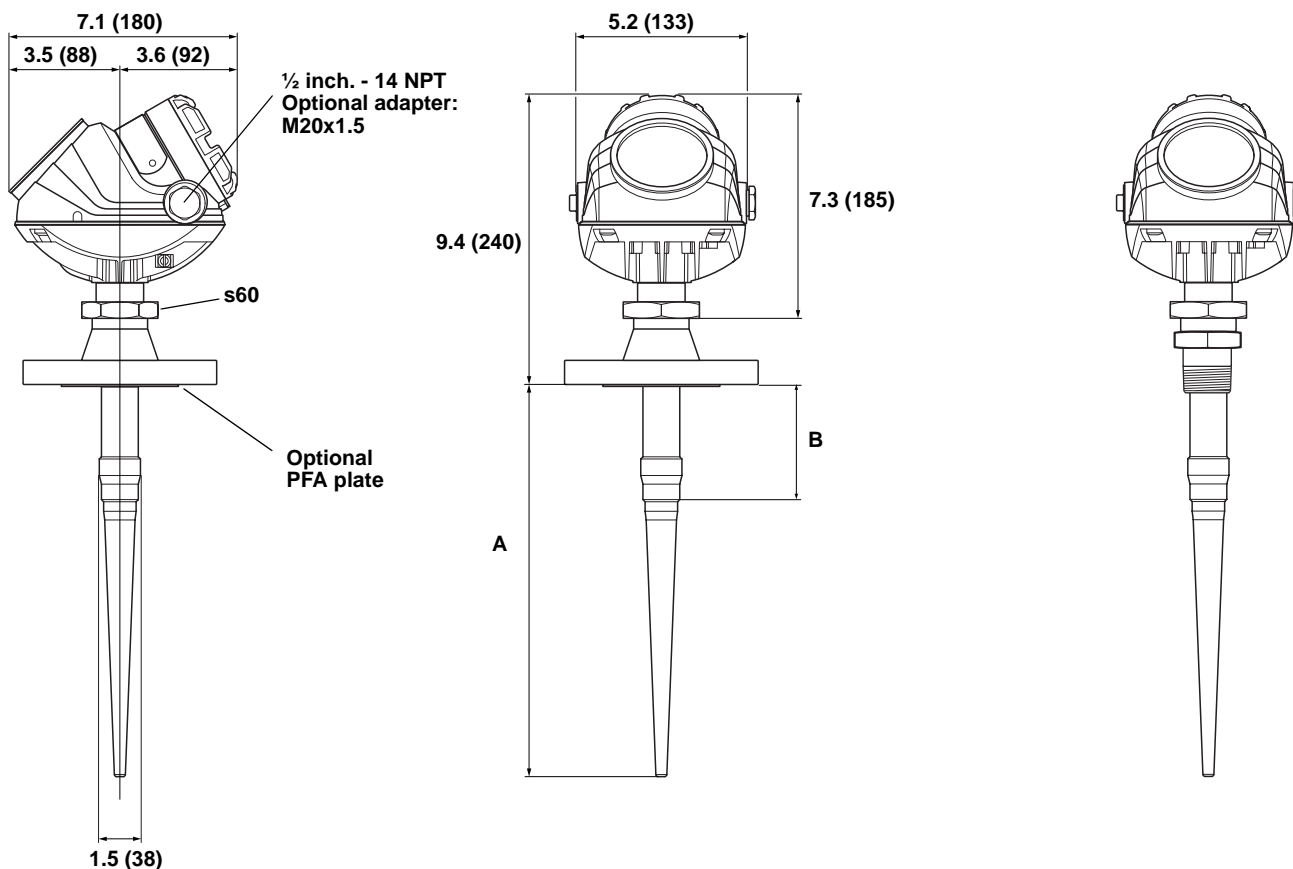

Rod	A	B
Short	14.4 (365)	3.94 (100)
Long	20.3 (515)	9.84 (250)

NOTE

All-PFA rod antennas (1R and 2R) have a PFA plate and are therefore only available with flanged connection. SST+PFA rod antennas (3R and 4R), which are not equipped with a PFA plate, are available either with flanged or threaded connection.

All dimensions are in inches (mm).

ROSEMOUNT 5400 SERIES WITH PROCESS SEAL ANTENNA

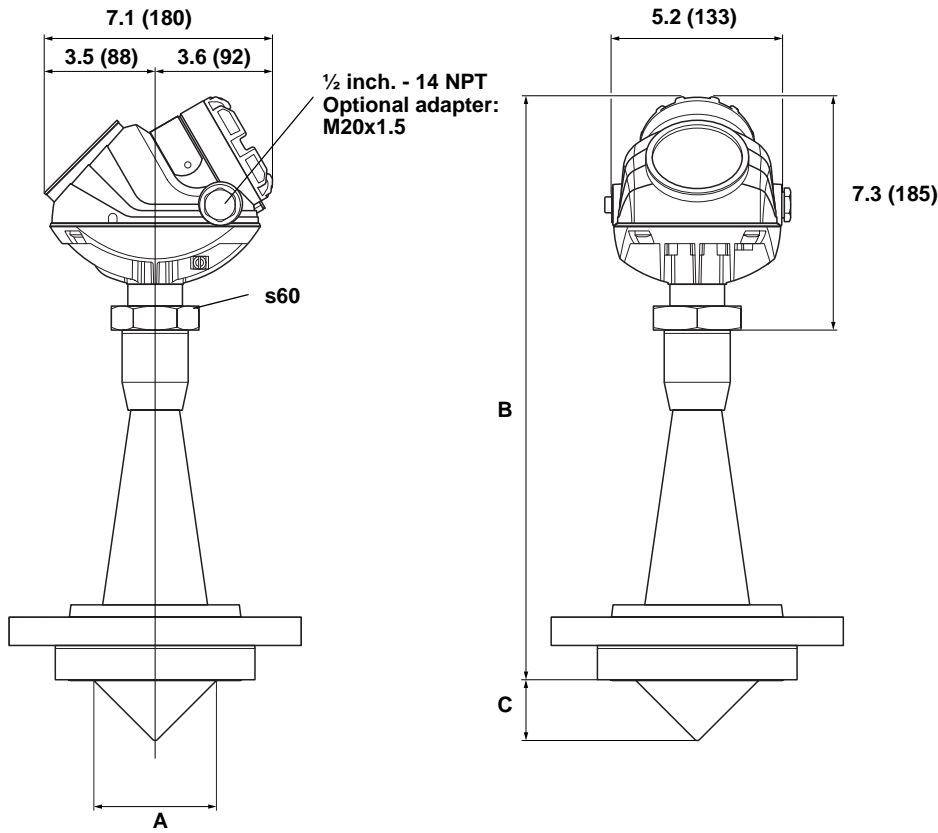

Process Seal size (inch)	A	B	C
2	1.8 (46)	14.2 (360)	0.9 (22)
3	2.8 (72)	17.3 (440)	1.4 (35)
4	3.8 (97)	18.9 (480)	1.9 (48)

Rosemount 5400 Series

Ordering Information

Model Code for Rosemount 5401 Radar Level Transmitter

Model	Product Description
5401	Low frequency version (~6 GHz)
Code	Housing Material
A	Polyurethane-covered Aluminum
Code	Signal Output
H	4-20 mA with HART [®] communication
F	FOUNDATION [™] fieldbus
Code	Conduit / Cable Threads
1	1/2 inch - 14 NPT
2	M20 x 1.5 adapter
Code	Product Certifications
NA	No Product Certificates
E1	ATEX Flameproof
I1	ATEX Intrinsic Safety
IA	ATEX FISCO Intrinsic Safety ⁽¹⁾
E5	FM Explosionproof
I5	FM Intrinsic Safety and Non-incendive
IE	FM FISCO Intrinsic Safety ⁽¹⁾
E6	CSA Explosionproof
I6	CSA Intrinsic Safety
IF	CSA FISCO Intrinsic Safety ⁽¹⁾
E7	IECEX Flameproof (pending)
I7	IECEX Intrinsic Safety (pending)
IG	IECEX FISCO Intrinsic Safety ⁽¹⁾ (pending)
Code	Antenna - Size and Material
Cone Antennas	
3S	3 in. DN 80, 316 L SST (EN 1.4404), pipe installations only
4S	4 in. DN 100, 316 L SST (EN 1.4404)
6S	6 in. DN 150, 316 L SST (EN 1.4404)
8S	8 in. DN 200, 316 L SST (EN 1.4404)
3H	3 in. DN 80, Hastelloy [®] C-276 (UNS N10276) ⁽²⁾ with plate design, pipe installations only
4H	4 in. DN 100, Hastelloy [®] C-276 (UNS N10276) ⁽²⁾ with plate design
6H	6 in. DN 150, Hastelloy [®] C-276 (UNS N10276) ⁽²⁾ with plate design
8H	8 in. DN 200, Hastelloy [®] C-276 (UNS N10276) ⁽²⁾ with plate design
3M	3 in. DN 80, Monel [®] 400 (UNS N04400) ⁽²⁾ with plate design, pipe installations only
4M	4 in. DN 100, Monel [®] 400 (UNS N04400) ⁽²⁾ with plate design
6M	6 in. DN 150, Monel [®] 400 (UNS N04400) with plate design
8M	8 in. DN 200, Monel [®] 400 (UNS N04400) ⁽²⁾ with plate design
Rod Antennas	
1R	100 mm inactive length, all-PFA ⁽³⁾⁽⁴⁾
2R	250 mm inactive length, all-PFA ⁽³⁾⁽⁴⁾
3R	100 mm inactive length, SST+ PFA ⁽³⁾
4R	250 mm inactive length, SST+ PFA ⁽³⁾
Other Antennas	
XX	Customer specific
Code	Tank Seal
PV	PTFE with Viton [®] fluoroelastomer o-rings
PK	PTFE with Kalrez [®] 6375 perfluoroelastomer o-rings
PE	PTFE with EPDM o-rings
PB	PTFE with Buna-N o-rings
PD	All-PFA ⁽³⁾⁽⁵⁾

Product Data Sheet

00813-0100-4026, Rev EA

October 2005

Rosemount 5400 Series

Code	Process Connection and Material
ANSI Flanges	
AA	2 inch, 150 lbs, 316 / 316 L SST ⁽⁶⁾
AB	2 inch, 300 lbs, 316 / 316 L SST ⁽⁶⁾
BA	3 inch, 150lbs, 316 / 316 L SST
BB	3 inch, 300 lbs, 316 / 316 L SST
CA	4 inch, 150 lbs, 316 / 316 L SST
CB	4 inch, 300 lbs, 316 / 316 L SST
DA	6 inch, 150 lbs, 316 / 316 L SST
EA	8 inch, 150 lbs, 316 / 316 L SST
EN (DIN) Flanges	
HB	DN 50 PN 40, SST (EN 1.4404) ⁽⁶⁾
IB	DN 80 PN 40, SST (EN 1.4404)
JA	DN 100 PN 16, SST (EN 1.4404)
JB	DN 100 PN 40, SST (EN 1.4404)
KA	DN 150 PN 16, SST (EN 1.4404)
LA	DN 200 PN 16, SST (EN 1.4404)
Threaded	
RA	1.5-in. NPT, 316 L SST (EN 1.4404) ⁽⁷⁾
Other	
XX	Customer specific
Code	Options
M1	Integral digital display
BT	Bar Code Tag with tag number and purchase order number
T1	Transient Protection Terminal Block (standard with FISCO options)
Software Configuration	
C1	Factory configuration (CDS required with order)
Alarm Limit Configuration	
C4	NAMUR alarm and saturation levels, high alarm
C8	Low alarm ⁽⁸⁾ (standard Rosemount alarm and saturation levels)
Special Certificates	
Q4	Calibration Data Certificate
Q8	Material Traceability Certification per EN 10204 3.1B ⁽⁹⁾
Special Procedures	
P1	Hydrostatic testing

Typical Model Number: 5401 A H 1 NA 4S PV CA - M1 C1

- (1) Requires Foundation™ fieldbus signal output (U₁ parameter listed in "Product Certificates" on page 16).
- (2) Requires flange of same size.
- (3) PFA is a fluoropolymer with properties similar to PTFE.
- (4) Requires All-PFA tank seal (PD).
- (5) Requires All-PFA Rod antennas (1R or 2R).
- (6) Requires Rod antennas (1R, 2R, 3R or 4R)
- (7) Requires Rod antenna in SST+PFA (3R or 4R).
- (8) Standard alarm setting is high.
- (9) Option available for pressure retaining metal parts.

Rosemount 5400 Series

Model Code for Rosemount 5402 Radar Level Transmitter

Model	Product Description
5402	High frequency version (~26 GHz)
Code	Housing Material
A	Polyurethane-covered Aluminum
Code	Signal Output
H	4-20 mA with HART® communication
F	FOUNDATION™ fieldbus
Code	Conduit / Cable Threads
1	1/2 inch - 14 NPT
2	M20 x 1.5 adapter
Code	Product Certifications
NA	No Product Certificates
E1	ATEX Flameproof
I1	ATEX Intrinsic Safety
IA	ATEX FISCO Intrinsic Safety ⁽¹⁾
E5	FM Explosionproof
I5	FM Intrinsic Safety and Non-incendive
IE	FM FISCO Intrinsic Safety ⁽¹⁾
E6	CSA Explosionproof
I6	CSA Intrinsic Safety
IF	CSA FISCO Intrinsic Safety ⁽¹⁾
E7	IECEX Flameproof (pending)
I7	IECEX Intrinsic Safety (pending)
IG	IECEX FISCO Intrinsic Safety ⁽¹⁾ (pending)
Code	Antenna - Size and Material
Cone Antennas	
2S	2 in. DN 50, 316 L SST (EN 1.4404) ⁽²⁾
3S	3 in. DN 80, 316 L SST (EN 1.4404)
4S	4 in. DN 100, 316 L SST (EN 1.4404)
2H	2 in. DN 50, Hastelloy® C-276 (UNS N10276) ⁽²⁾ with plate design
3H	3 in. DN 80, Hastelloy® C-276 (UNS N10276) ⁽²⁾ with plate design
4H	4 in. DN 100, Hastelloy® C-276 (UNS N10276) ⁽²⁾ with plate design
2M	2 in. DN 50, Monel® 400 (UNS N04400) ⁽²⁾ with plate design
3M	3 in. DN 80, Monel® 400 (UNS N04400) ⁽²⁾ with plate design
4M	4 in. DN 100, Monel® 400 (UNS N04400) ⁽²⁾ with plate design
Process Seal Antennas	
2P	2 in. DN 50, PTFE ⁽³⁾
3P	3 in. DN 80, PTFE ⁽⁴⁾
4P	4 in. DN 100, PTFE ⁽⁵⁾
Other Antennas	
XX	Customer specific
Code	Tank Sealing
PV	PTFE with Viton® fluoroelastomer o-rings
PK	PTFE with Kalrez® 6375 perfluoroelastomer o-rings
PE	PTFE with EPDM o-rings
PB	PTFE with Buna-N o-rings

Product Data Sheet

00813-0100-4026, Rev EA

October 2005

Rosemount 5400 Series

Code	Process Connection and Material
ANSI Flanges	
AA	2 inch, 150 lbs, 316 / 316 L SST ⁽⁶⁾
AB	2 inch, 300 lbs, 316 / 316 L SST ⁽⁶⁾
BA	3 inch, 150 lbs, 316 / 316 L SST
BB	3 inch, 300 lbs, 316 / 316 L SST
CA	4 inch, 150 lbs, 316 / 316 L SST
CB	4 inch, 300 lbs, 316 / 316 L SST
DA	6 inch, 150 lbs, 316 / 316 L SST
EA	8 inch, 150 lbs, 316 / 316 L SST
EN (DIN) Flanges	
HB	DN 50 PN 40, SST (EN 1.4404) ⁽⁶⁾
IB	DN 80 PN 40, SST (EN 1.4404)
JA	DN 100 PN 16, SST (EN 1.4404)
JB	DN 100 PN 40, SST (EN 1.4404)
KA	DN 150 PN 16, SST (EN 1.4404)
LA	DN 200 PN 16, SST (EN 1.4404)
Other Flanges	
XX	Customer specific
Code	Options
M1	Integral digital display
BT	Bar Code Tag with tag number and purchase order number
T1	Transient Protection Terminal Block (standard with FISCO options)
Software Configuration	
C1	Factory configuration (CDS required with order)
Alarm Limit Configuration	
C4	NAMUR alarm and saturation levels, high alarm
C8	Low alarm ⁽⁷⁾ (standard Rosemount alarm and saturation levels)
Special Certificates	
Q4	Calibration Data Certificate
Q8	Material Traceability Certification per EN 10204 3.1B ⁽⁸⁾
Special Procedures	
P1	Hydrostatic testing
Typical Model Number: 5402 A H 1 E5 4S PV CA - M1 C1	

- (1) Requires Foundation™ fieldbus signal output (U, parameter listed in "Product Certificates" on page 16).
- (2) Requires flange of same size.
- (3) Requires 2 in. / DN 50 flanges (AA, AB or HB).
- (4) Requires 3 in. / DN 80 flanges (BA, BB or IB).
- (5) Requires 4 in. / DN 100 flanges (CA, CB, JA or JB).
- (6) Requires a 2 in. antenna (code 2S).
- (7) Standard alarm setting is high.
- (8) Option available for pressure retaining metal parts.

Rosemount 5400 Series

Application & Configuration Data Sheet

*=Indicates default factory configuration.

Customer Information, Model Number and Tagging Information - Information is required if C1 is ordered

Customer / End User _____ Customer Contact _____
 Sales Person _____ Customer Phone/E-mail _____
 P.O. Number _____ Line Item _____ Ultimate Destination _____

Model Number
 Options

Hardware Tag (max 21 characters)
 Software Tag (max 8 characters)

Process Information

Process Name _____ Product Type _____

Process Description _____

Dielectric Constant 1.9-2.5 2.5-4.0 4.0-10 >10 (water based) Unknown
 Process Temperature **Min:** _____ **Max:** _____ °F °C
 Process Pressure **Min:** _____ **Max:** _____ psig Bar

Is the process turbulent? No Slightly Aggressive
 If turbulent, due to Agitation Vortex Flowing Splash Loading

Foam None Light, airy Heavy, dense
 If foam, it is present Constantly Occasionally
 If foam, thickness _____ inch mm

Condensation / Dirt None Light Heavy

Variable Units (choose only one of each group)

Use this unit when filling in values in the Application & Configuration Data Sheet.

If Level ft in m cm mm*
 If Volume⁽¹⁾ ft³ in³ US gals Barrels m³* liters

LCD Meter Configuration - Only if M1 and C1 is ordered

Variables Level Distance Volume % of Level Range⁽²⁾ Level Rate
 Variable units are displayed according to the above. If more than one variable is chosen, Carousel Toggling of data is used.

Security Information - Information is required if C1 is ordered

Write Protect On Off*

(1) If volume calculation is required, fill in Application and Configuration Data Sheet, Volume Configuration.
 (2) Not applicable for FOUNDATION™ fieldbus.

Application & Configuration Data Sheet, continued

*=Indicates default factory configuration.



Analog Output (4-20 mA analog output), not applicable for FOUNDATION™ fieldbus devices - Information is required if C1 is ordered

Primary Variable (PV) Level* Distance Volume Level Rate⁽¹⁾ Signal Strength⁽²⁾

Lower Range Value (4 mA) _____ (use the selected variable unit on previous page)

Upper Range Value (20 mA) _____ (use the selected variable unit on previous page)

Alarm Mode High* Low Freeze

Tank Geometry - Information is required if C1 is ordered

Tank Shape Select a tank type corresponding to the actual tank on which the device is mounted. If the device is mounted on a tank type that is not available as an individual selection choose Unknown.

- Unknown* Vertical Cylinder Horizontal Cylinder
 Spherical Cubical⁽³⁾

Tank Bottom⁽⁴⁾ Select a Tank Bottom Type that corresponds to the actual shape of the tank bottom.

- Unknown* Flat⁽⁵⁾ Dome/Dish/Bullet

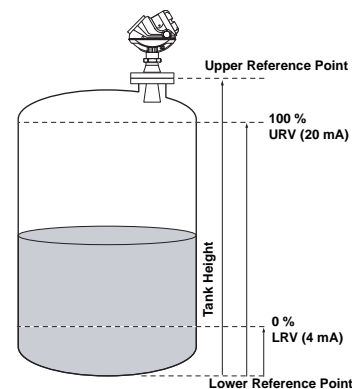
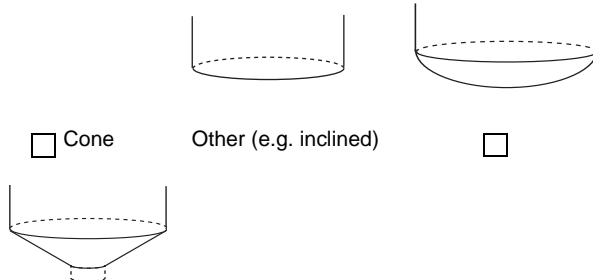

Tank Height _____ (use variable unit chosen on previous page)

(1) Always in selected level unit per second.
 (2) Always in mV.
 (3) A cubical tank type is defined as a box shaped tank with right angles.
 (4) Tank Bottom Type is only applicable for Vertical Cylinder and Cubical tanks.
 (5) Bottom of the tank is < 5°.

Application & Configuration Data Sheet, continued

Fitting Dimensions - Information is required if C1 is ordered

Please fill in the dimensions (according to selected variable unit)

Nozzle

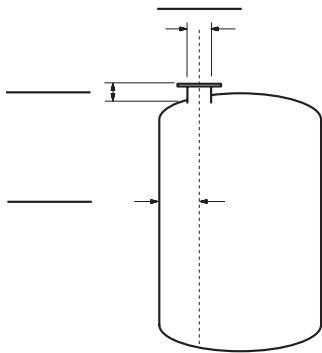

Stilling Well

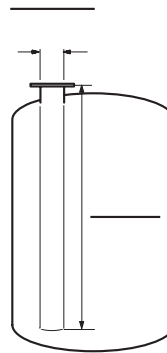

Bypass Pipe

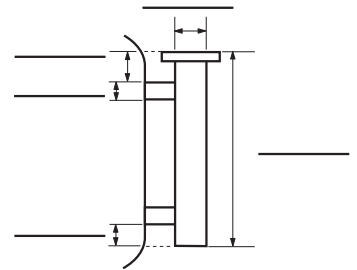

Application & Configuration Data Sheet, continued

VOLUME CONFIGURATION

Volume Configuration Information (total volume calculation only) - Required if C1 is ordered and Volume is chosen variable

Volume is calculated based on ideal tank types or a strapping table. Please mark the box that corresponds to your tank type and fill in dimensions on the lines according to the previously selected variable unit.

Vertical Cylinder

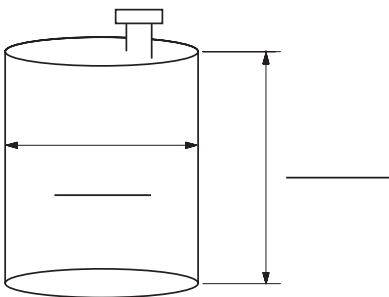

Horizontal Cylinder

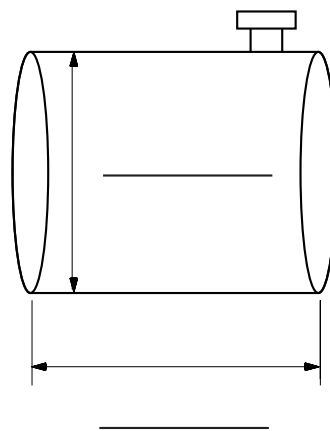

Vertical Cylinder with Bullet Ends

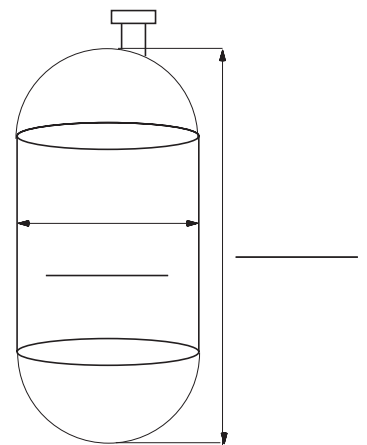

Horizontal Cylinder with Bullet Ends

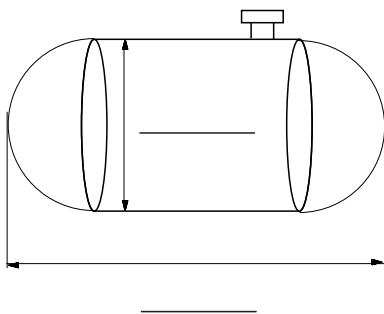

Sphere

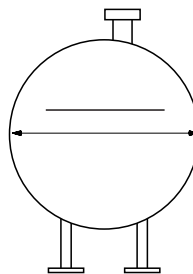

Rosemount 5400 Series

Product Data Sheet
00813-0100-4026, Rev EA
October 2005

Product Data Sheet

00813-0100-4026, Rev EA

October 2005

Rosemount 5400 Series

Rosemount Level Solutions

Emerson provides a complete range of Rosemount products for level measurement applications.

Pressure – Level or Interface Measurement

Emerson has a complete line of Rosemount pressure transmitters and remote seals for measuring level or interfaces in liquid applications. Optimize performance with direct mount, Tuned Seal systems:

- Rosemount 3051S_L, 3051L, and 1151LT Liquid Level Transmitters
- Rosemount 1199 Remote Diaphragm Seals with direct mount or capillary connections

Guided Wave Radar – Level and Interface Measurement

The reliable Rosemount 3300 Series consists of:

- Rosemount 3301 for level measurements of liquids and solids
- Rosemount 3302 for level and interface measurement of liquids

Both can be equipped with a wide range of probes for different applications.

Non-contacting Radar – Level Measurement

The Rosemount non-contacting radar family consists of:

- Rosemount 5400 Series Transmitters – The two loop-powered models utilize different transmitter frequencies, and both can be equipped with a wide range of antennas for liquid level measurement in most applications and process conditions
- Rosemount 5600 Series Transmitters – These radar level transmitters have ultra-high sensitivity and are the perfect choice for measuring level of liquids and solids, even for the most challenging applications

Vibrating Fork Switches – Point Level Detection

The Rosemount 2100 Series is developed for reliable point level measurement of liquids and consists of:

- Rosemount 2110 Compact Vibrating Fork Liquid Level Switch
- Rosemount 2120 Universal Vibrating Fork Liquid Level Switch

*Rosemount and the Rosemount logotype are registered trademarks of Rosemount Inc.
PlantWeb is a registered trademark of one of the Emerson Process Management group of companies.
HART is a registered trademark of the HART Communication Foundation
Teflon, Viton, and Kalrez are registered trademarks of Du Pont Performance Elastomers.
FOUNDATION is a trademark of the Fieldbus Foundation.
DeltaV is a trademark of Emerson Process Management group of companies.
Hastelloy is a registered trademark of Haynes International.
Monel is a registered trademark of International Nickel Co.
All other marks are the property of their respective owners.*

Emerson Process Management, Rosemount Inc.

The Americas

Emerson Process Management
8200 Market Boulevard
Chanhassen, MN 55317 USA
T (U.S.) 1-800-999-9307
T (International) (952) 906-8888
F (952) 949-7001

Europe, Middle East & Africa

Emerson Process Management
Shared Services Ltd.
Heath Place
Bognor Regis
West Sussex PO22 9SH
England
Tel 44 1243 845500
Fax 44 1243 867554

Asia Pacific

Emerson Process Management
Singapore Pte Ltd.
1 Pandan Crescent
Singapore 128461
Tel 65 6777 8211
Fax 65 6777 0947
AP.RMT-Specialist@emersonprocess.com

www.rosemount.com



© 2005 Rosemount Inc. All rights reserved.

EMERSON
Process Management