

Product Data Sheet

PDS 106-340.Xi

May, 2010

Rosemount Analytical Xi Advanced Electronics for Zirconium Oxide Oxygen Probes

- Excellent accuracy
- Large backlit display and keypad
- NEMA 4X enclosure
- Works with Westinghouse/Rosemount, and most competitive ZrO₂ probes
- HART communications standard (AMS aware)
- Wireless - via THUM™ Adaptor
- Advanced Features
 - Calibration recommended diagnostic
 - Automatic calibration capability
 - Extended process temperature ranges
 - Stoichiometer feature
 - Programmable reference
 - Loss-of-flame heater cut-out



The zirconium oxide sensing technology for measuring the excess oxygen in combustion flue gases has gained prominence over the past several decades. This versatile electronics is specifically designed to run most O₂ probes manufactured. The large backlit LCD display makes it easy to set up and operate. Fully automatic calibrations may be executed from this electronics with the addition of a small solenoid box for switching calibration gases.

Automatic Calibration

Plant personnel often ask how frequently an oxygen analyzer requires calibration. The answer is very application-dependent based upon the fuels being burned, normal levels of oxygen and the sulfur content in the flue gases. The X-STREAM Xi addresses this concern by providing an on-line diagnostic that determines when a calibration should be conducted, eliminating many unneeded calibrations and the technician and gas resources

they consume. The X-STREAM electronics has an on-line impedance measurement for the sensing cell.

This feature can trigger a fully automatic calibration by sequencing solenoids to introduce calibration gases to the sensing cell. The Single Probe Sequencer (SPS) switches CAL gases to a single probe, while a Multi-Probe Sequencer (IMPS) can handle 1 to 4 probes. Many needless calibrations based on “time in service” are eliminated. A contact closure notifies the control room when a calibration is taking place. The oxygen output signal can be held at its last value, or released during calibration. The X-STREAM can also initiate calibrations by traditional methods:

- Contact closure from the user’s control room
- Time since last calibration feature
 - established by the autocalibration system
- Xi enhanced interface
- HART/AMS

ROSEMOUNT
Analytical

Visit our website at www.raihome.com
On-line ordering available.

EMERSON
Process Management

The Xi electronics offers the following unique advanced features never before offered for O₂ probes:

Extended Process Temperature Range -

Traditional O₂ electronics will go into alarm if the process temperature exceeds the controlled heater temperature. This feature enables the Xi to turn off the internal heater in this event, use the process temperature to heat the cell, and calculate O₂ on the fly from the changing process temperatures. Note that accelerated probe and cell damage may occur as a result of extended operation above 800°C (1462°F), but at least the measurement will not go off-line during this event.

Stoichiometer - Process upsets can sometimes cause a combustion process to go into substoichiometric or reducing conditions. The oxygen readings from one or more probes may decline all the way to zero. The stoichiometer cell will measure the amount of oxygen deficiency during these reducing conditions. The trends in your DCS can be set up for a lower range limit of -1 or -2% oxygen to depict the level of oxygen deficiency. The operator can see if his control actions to recover are having the desired effect. These types of events do not occur frequently, but knowing the parameters of the situation prevents overcorrecting while coming out of the reducing condition.

Programmable Reference

– enhances operation for the following applications:

Moisture Monitoring – measuring the amount of moisture coming off of industrial dryers by noting the dilution effect water vapor has on the normal 20.95% ambient drying air.

Enriched Oxygen Combustion – Pure oxygen is sometimes mixed in with the combustion air to increase heat at the flame. This is used in steel and other metals reduction processes and also in some catalyst regenerators.

Flame Safety Interlock – dry contact from a flame safety system removes power from the probe heater in a loss-of-flame event.

Environmental Specifications

General Purpose Certifications:



Xi Ambient Temp.Limits:

-20° to 55°C (-4° to 131°F)

Xi Temp. Limits as measured inside the housing:

-20° to 55°C (-4° to 113°F)

Xi LCD display Temp. Limits:

-20° to 55°C (-4° to 131°F)

Installation Specifications

Electrical Power of Oxymitter or optional Xi electronics:

120 to 240V, ±10% 50/60 Hz

Power Consumption of Xi:

10 watts maximum

Xi Alarms Relays:

2 provided - 2 amps, 30 VDC

Xi Optional Loss of Flame Contact:

Removes heater power

Electrical Noise:

Meets EN 61326, Class A

Power:

100-240V ±10%, 50-60Hz

Power Consumption of Xi:

12VA maximum or 776VA maximum with Traditional Architecture, 120V, Probes. 450VA maximum with Traditional Architecture, 44V Probes

Alarm Relay Outputs:

Two provided - 2 Amperes, 30 VDO, Form-C

Optional Loss of Flame Input:

internally power input to remove heater power, actuated via dry contact output from proof-of-flame device.



Emerson Process Management has satisfied all obligations coming from the European legislation to harmonize the product requirements in Europe.

¹ All static performance characteristics are with operating variables constant. Specifications subject to change without notice.

Xi Enhanced Interface - Panel Mounting Details

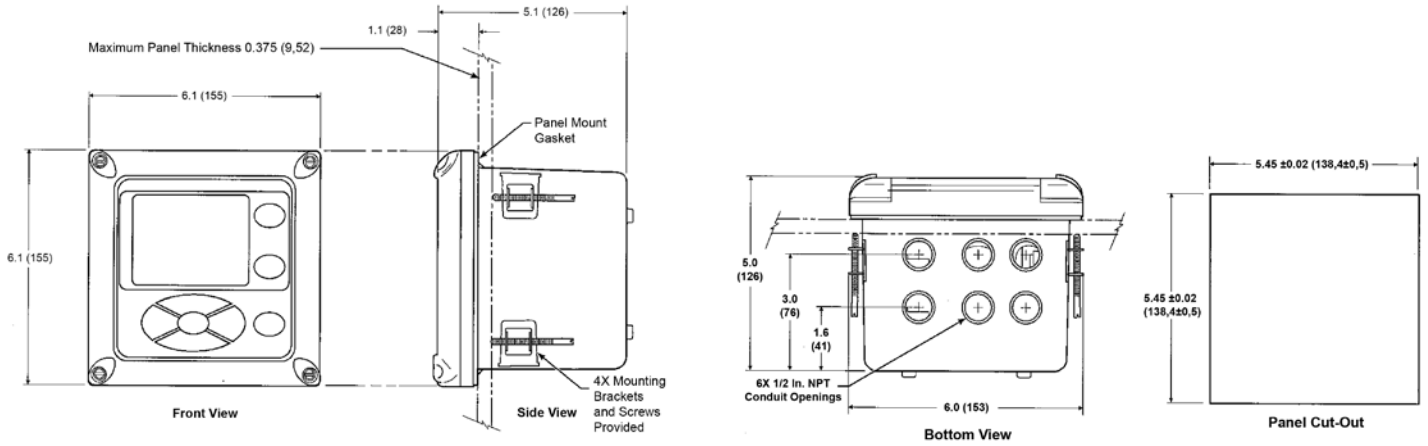

Xi Enhanced Interface - Wall/Surface and Pipe Mounting Details

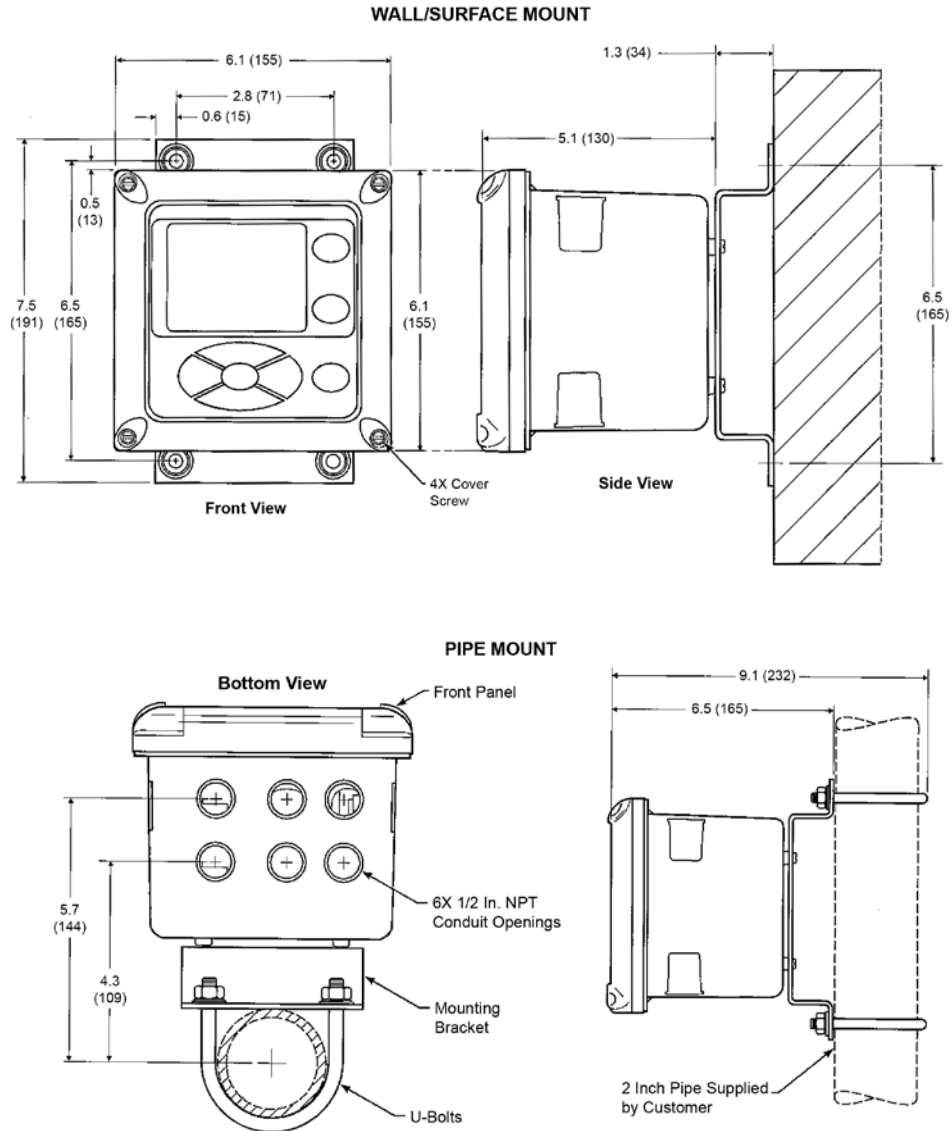

ORDERING INFORMATION – Xi ADVANCED ELECTRONICS

Model	Description
Xi	O ₂ Advanced electronics

Level 1	Type
01	Single Channel
02	Single Channel with Flame Safety Interlock for Heater
03	Dual Channel
04	Single Channel, Traditional Architecture for 120V Probes
05	Single Channel, Traditional Architecture for 44V Probes

Level 2	Mounting
00	None
01	Panel Mount Kit with Gasket
02	2" Pipe/Wall Mount Kit

Level 3	Cable
00	None
10	20' (6m) Cable
11	40' (12m) Cable
12	60' (18m) Cable
13	80' (24m) Cable
14	100' (30m) Cable
15	150' (45m) Cable
16	200' (60m) Cable

Level 4	Stoichiometer Function ¹
00	None
01	Single Channel
02	Dual Channel, (second channel not available for traditional architecture Xi)

Level 5	Programmable Reference Function ¹
00	None
01	Single Channel
02	Dual Channel, (second channel not available for traditional architecture Xi)

Level 6	Extended Process Temperature (825°C)/Heaterless Operation
00	None
01	Single Channel
02	Dual Channel, (second channel not available for traditional architecture Xi)

Notes: ¹ Software features may be added in the field after shipment
Wireless THUM™ Adaptor is ordered separately.

The contents of this publication are presented for informational purposes only, and while every effort has been made to ensure their accuracy, they are not to be construed as warranties or guarantees, express or implied, regarding the products or services described herein or their use or applicability. All sales are governed by our terms and conditions, which are available on request. We reserve the right to modify or improve the designs or specifications of our products at any time without notice.

To find the local Rosemount Analytical specialist near you, go to:
http://www.emersonprocess.com/raihome/sp/contact_us.asp.



EMERSON
Process Management