

PanaFlow™ ISX

Panometrics Ultrasonic Liquid Flowmeter

Applications

The Panometrics PanaFlow ISX ultrasonic flowmeter is a complete loop-powered system that is intrinsically safe. It can be used for a variety of liquid applications, such as:

- Hydrocarbon liquids
- Water
- Solvents
- Weak acids
- Petroleum products
- Lubricating oils
- Diesel fuel oil
- Chemicals
- Other liquids



Features

- Intrinsically safe
- Economical solution
- Two-wire, loop-powered device
- Low power consumption
- 0.5% accuracy
- Optional remote mount of electronics
- No moving parts
- Excellent low-end resolution
- Fast, simple installation
- Suitable for pipe sizes from 4 in to 24 in (100 mm to 600 mm) diameter
- Bidirectional



PanaFlow ISX is the latest addition to the PanaFlow family of flowmeters. PanaFlow ISX combines the Panametrics transducer and signal processing technologies to provide superior accuracy. Its compact package is an economical solution for ultrasonic liquid flow measurement in hazardous areas.

Benefits of Transit-Time Technology

Ultrasonic flowmeter technology offers a number of benefits, including excellent low-end resolution, no pressure drop, high-temperature and high-pressure limits, low maintenance, and flow measurement without obstruction.

The meter's patented digital signal-processing and cross correlation techniques combined with better noise immunity greatly increase the signal-to-noise ratio for accurate and drift-free flow measurement. Path configuration is optimized to ensure accurate flow measurement independent of liquid viscosity.

Advances in ultrasonic transducer technology have resulted in reducing the drive voltage needed to power transducers by a factor of ten. This significant reduction makes it possible for the PanaFlow ISX to achieve an intrinsically safe rating.

Transit-Time Theory

In operation, each transducer functions as a transmitter, generating a certain number of acoustic pulses, and then as a receiver for an identical number of pulses. The time interval between transmission and reception of the ultrasonic signals is measured in both directions. When the liquid in the pipe is not flowing, the transit-time downstream equals the transit-time upstream. When the liquid is flowing, the transit-time downstream is less than the transit-time upstream.

The difference between the downstream and upstream transit times is proportional to the velocity of the flowing liquid, and its sign indicates the direction of flow.

Automatically Adjusts to Changing Fluid

Standard in all PanaFlow ISX transmitters, is our unique Automatic Tracking Window™ (ATW™) feature that ensures accurate flow measurements even when fluid properties are unknown or changing. Like the seek mode on your car stereo, ATW dynamically sweeps the receiver window whenever the sound speed of the fluid changes. This powerful feature lets you measure flow when the fluid sound speed is unknown, is changing due to large temperature shifts, or when a new liquid starts to flow in a multiproduct pipeline.

ATW works by searching for a reliable ultrasonic receive signal. It does this by varying the time between the transmit signal and the receive signal window until the receive signal is found. The tracking window automatically sweeps through a range of time intervals based on the minimum and maximum expected sound speeds programmed by the user.

The window moves (tracks) in response to changes in the fluid sound speed. Once the optimal signal is found, ATW locks onto it until another large change in sound speed occurs. When this happens, ATW returns to the seek mode until the optimal signal is found again.

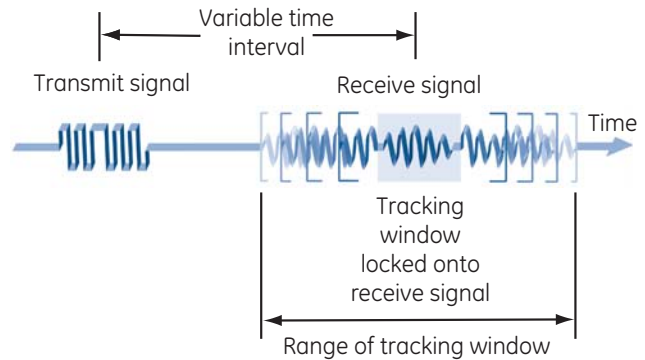

ATW ensures accuracy when fluid conditions change

Fast and Easy Installation

PanaFlow ISX is fast and easy to install because of its compact size, enabling it to fit into tight areas where other meters cannot fit. It is a two-wire device requiring low power so it can utilize an existing two-wire installation, saving the cost of running additional AC or DC power lines.

Local or Remote Electronics

The ISX electronics package can be factory-installed on the meter body or remotely located up to 50 ft (15 m) from the meter body. It is not recommended to mount electronics on applications above 149°F (65°C). The ISX electronics package is already programmed with set-up information based on your application, so the system is ready to use as soon as the meter body is installed.

PanaFlow ISX Specifications

Sensor Specification

Fluid Types

Acoustically conductive fluids, including most clean liquids, and many liquids with entrained solids or gas bubbles.

Pipe Sizes

4 in to 24 in (100 mm to 600 mm)

Flow Accuracy (Velocity)

0.5% accuracy 2 to 40 ft/sec (0.6 to 12 m/s)

Accuracy specification assumes a fully developed flow profile (typically 10 diameters upstream and 5 diameters downstream of straight pipe run) and single-phase fluids with constant viscosity. Applications with piping arrangements that induce swirl (e.g., two out-of-plane elbows) may require additional straight run or flow conditioning.

Repeatability

±0.1 to 0.3% of reading

Range (Bidirectional)

See Installation Requirements Table on the following page

Rangeability (Overall)

400:1

Measurement Parameters

Volumetric flow, totalized flow and flow velocity.

Temperature Ranges

-40°F to 285°F (-40°C to 140°C)

Pressure Class

ANSI 150

ANSI 300

PN 16 Pending

PN 40 Pending

Pipe Materials

- Carbon steel
- Stainless steel (304SS or 316SS)

Sensor Materials

Standard: Viton and Titanium

Optional: EDPM and Titanium. Others per special request

Electronics Specification

Flow Measurement

Patented Correlation Transit-Time mode

Enclosure

Epoxy-coated aluminum weatherproof Type 4X/IP66

Hazardous Location Certifications

II 1G EEx ia IIC T4 (-20° C < Ta < +60° C)

IS/I/1, II, III/ABCDEFG T4 Ta = 60° C

AEx ia IIC T4 Ta = 60° C

Dimensions (h x w x d)

8.8 in x 8.2 in x 3.6 in (220 mm x 210 mm x 90 mm)

Weight

3.9 lb (1.77 kg)

Display

128 x 64 pixel LCD graphic display

Keypad

Six-button external keypad

Power Supply

15 to 30 VDC loop power

In-rush current Max: 24 mA

Power Consumption

700 mW maximum

Memory

FLASH memory; field upgradeable

Operating Temperature

-4°F to 140°F (-20°C to 60°C)

Storage Temperature

-4°F to 158°F (-20°C to 70°C)

Standard Inputs/Output

One 4 to 20 mA on power loop

Recommended Safety Barrier

28 VDC, 93 mA for 4 to 20 mA

Digital Interface

RS232

European Compliance

System complies with EMC Directive 89/336/EEC

ANSI 150 Systems							
Nominal Pipe Size in (mm)	Overall Length (Face To Face)	A	B	C	D	Dry Weight lb (kg)	Maximum Flow gpm (lpm)
			Width in (mm)	Height in (mm)	Height Remote Display in (mm)		
4 (100)	19.00	(482.6)	11 (280)	19 (464)	17 (411)	69 (32)	1,600 (6,000)
6 (150)	20.00	(508.0)	13 (318)	21 (516)	19 (463)	98 (45)	3,600 (13,600)
8 (200)	25.00	(635.0)	14 (356)	23 (574)	21 (521)	157 (71)	6,200 (23, 600)
10 (250)	26.00	(660.4)	17 (432)	25 (632)	23 (579)	214 (97)	9,800 (37,200)
12 (300)	30.00	(762.0)	19 (483)	28 (696)	26 (643)	279 (127)	14,100 (53,400)
14 (350)	33.00	(838.2)	21 (534)	29 (737)	27 (684)	363 (165)	17,200 (65,100)
16 (400)	33.00	(838.2)	24 (597)	32 (794)	30 (741)	454 (206)	22,800 (86,200)
18 (450)	37.00	(939.8)	25 (635)	33 (839)	31 (786)	559 (254)	29,100 (110,300)
20 (500)	38.00	(965.2)	28 (699)	36 (896)	34 (843)	680 (309)	36,300 (137,300)
24 (600)	42.50	(1,079.5)	32 (813)	40 (1,004)	38 (951)	983 (446)	52,900 (200,300)

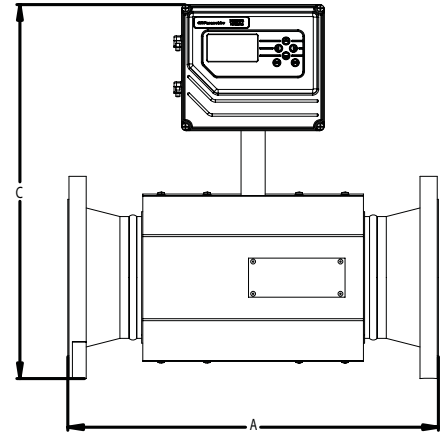

Front View with Electronics

ANSI 300 Systems							
Nominal Pipe Size in (mm)	Overall Length (Face To Face)	A	B	C	D	Dry Weight lb (kg)	Maximum Flow gpm (lpm)
			Width in (mm)	Height in (mm)	Height Remote Display in (mm)		
4 (100)	19.00	(482.6)	11 (280)	19 (477)	17 (424)	94 (43)	1,600 (6,000)
6 (150)	20.00	(508.0)	13 (318)	22 (535)	19 (482)	149 (68)	3,600 (13,600)
8 (200)	25.00	(635.0)	14 (356)	24 (593)	22 (540)	235 (107)	6,200 (23, 600)
10 (250)	26.00	(660.4)	17 (432)	26 (651)	24 (598)	338 (153)	9,800 (37,200)
12 (300)	30.00	(762.0)	21 (521)	29 (715)	27 (662)	456 (207)	14,100 (53,400)
14 (350)	33.00	(838.2)	23 (585)	30 (762)	28 (709)	554 (251)	17,200 (65,100)
16 (400)	33.00	(838.2)	26 (648)	33 (820)	31 (767)	670 (304)	22,800 (86,200)
18 (450)	37.00	(939.8)	28 (712)	35 (877)	33 (824)	853 (387)	29,100 (110,300)
20 (500)	38.00	(965.2)	31 (775)	37 (934)	35 (881)	1,026 (465)	36,300 (137,300)
24 (600)	42.50	(1,079.5)	36 (915)	42 (1,055)	40 (1,002)	1,518 (689)	52,900 (200,300)

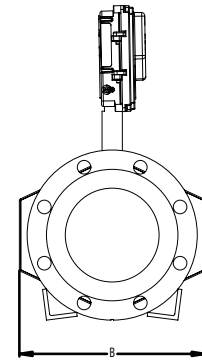

End View

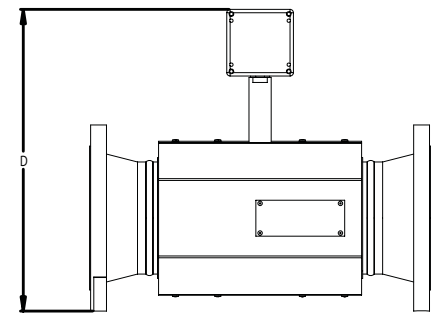

Front View with Junction Box



www.gesensinginspection.com

920-418B