

PRO MAG LTD

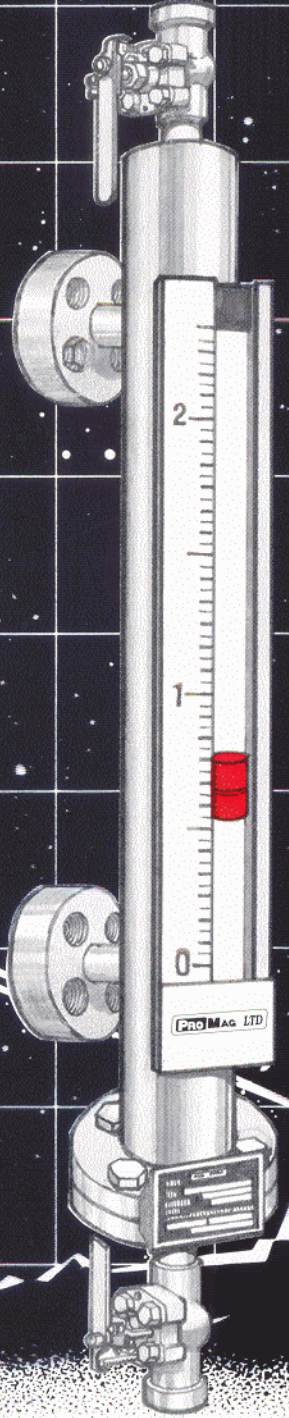
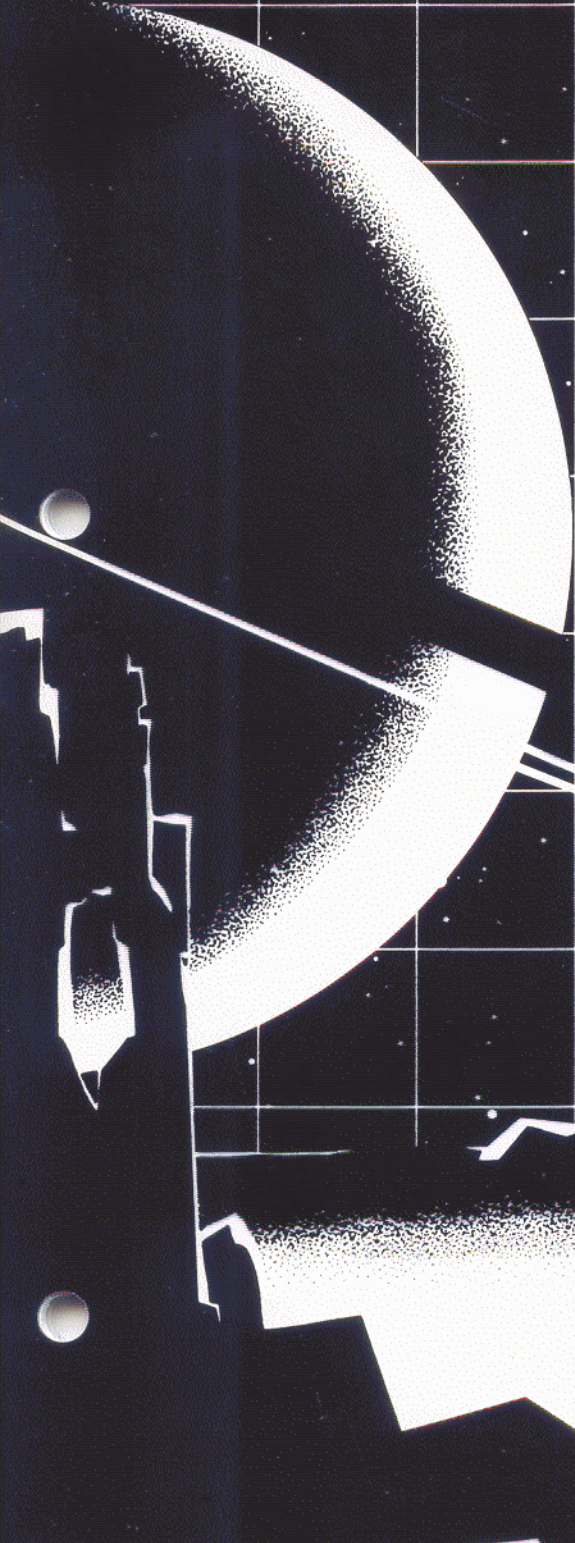
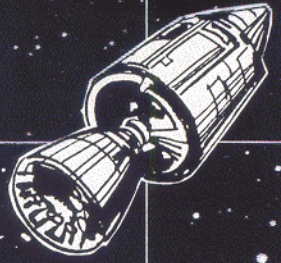

**THE GAUGE
OF THE
21st CENTURY
TODAY**

Engineering at its best! That's what PROMAG PM LTD offers. A unique design that will provide a **lifetime** of **safe** level indication. These state of the art **Magnetic Liquid Level Indicators** can be installed on almost any shape, size or type of vessel commonly used in industry today. If there is a non-magnetic material that's compatible with your process fluid, PROMAG PM LTD has a design that will give you **years of maintenance free service** -

We guarantee it

Compare !!!

The Standard features and versatility of the **PM-26**

The PROMAG PM LTD PM-26 Magnetic Liquid Level Indicator is a

DIRECT REPLACEMENT FOR LESS RELIABLE DEVICES

such as :

- DP Transmitters
- Tubular Gage
- Glass Ultrasonic
- Radar
- Sight Glass
- Boiler Gages
- Capacitance
- Displacement Type

FEATURES

- **SUPER ENVIROMENTAL And PERSONNEL PROTECTION**
- **NO GLASS** to break and leak process
- **FULL VACUUM** to 4,500 PSIG
- **-380 to 1000 °F**
- **SPECIFIC GRAVITIES** as low as 0.35
- **VESSEL LIQUID LEVEL INDICATION** from 6 to 720 INCHES
- **TOTAL LEVEL** and **INTERFACE LEVEL** measurements with the same unit. A difference of **0.10** minimum in specific gravity is all we need to give a distinct interface between two fluids.
- **EVERY PM-26 GAUGE** is **CUSTOM BUILT** to customer specification. This allows you to replace old and less reliable equipment, with a minimum of field modifications to your vessels.
- **UNIQUE FLUORESCENT INDICATOR** can be seen from **30 to 50 yards** away. This will eliminate many unnecessary, and sometimes dangerous trips to check levels in your tanks.
- **STRONG MAGNETIC ATTRACTION** between float and external indicator.
- **ULTIMATE FLASHING INDICATOR** for the most reliable indicator on the market today !

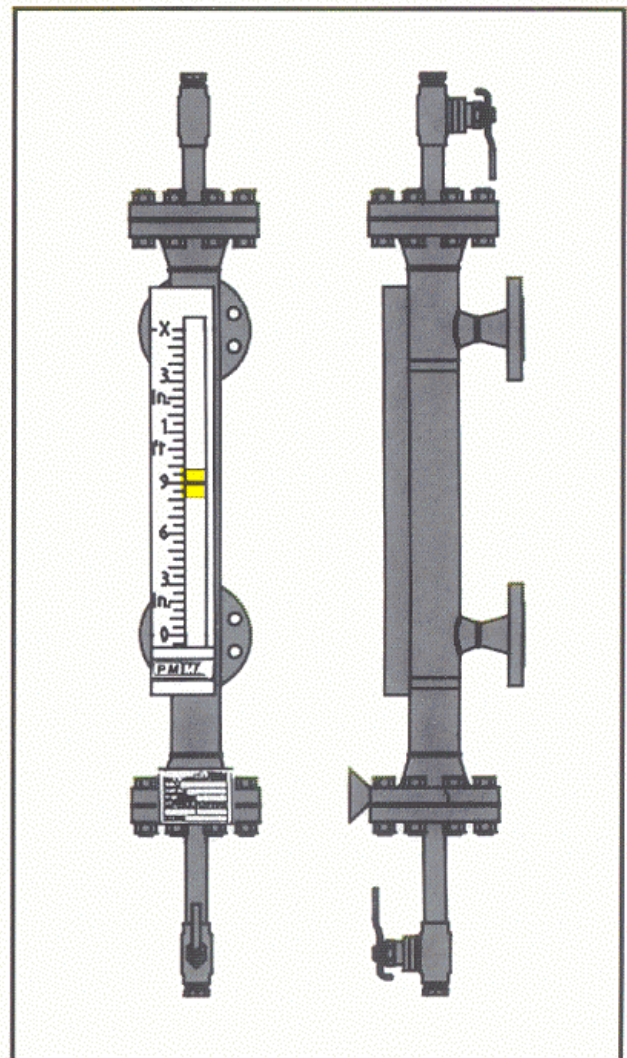

BENEFITS

- **Maintenance Free**
- **Safety**
- **Design**
- **Vibration Resistant**
- **Construction**
- **Direct Reading**
- **Positive Zero**

We Guarantee It !

SUPER Environmental, and Personnel Protection. Glass not in contact with Process Fluid. Therefore, No Leaks / Blow-Outs

Unlimited

Strong magnetic coupling between float and external follower

ASME Certified Welding, ASME Certified Materials, Hydro Testing

OPTIONS

- ▲ **Insulation**
- ▲ **Welding Certifications**
- ▲ **Special Materials**
- ▲ **Level Switches**
- ▲ **Continuous Level Transmission**
- ▲ **PID Controllers**
- ▲ **Special Scales**

Freeze Protection, Personnel Protection Cryogenic Service

X-Ray, U-Stamp, Stress Relief, NACE, Mill Test Reports

Monel, Hastelloy, Titanium, Alloy 20, Fiberglass, Kynar, PVC, CPVC, TFE Lined, Halar Coated,

Electric, Pneumatic, Fiber Optic

4-20 mA, 10-50 mA and 3-15 PSIG

4-20 mA, and 3-15 PSIG, Electro-Pneumatic Control

Percent, Gallons, Liters, 3" wide Acrylic Scales

APPLICATIONS from A to Zymurgy

Acetic Acid
Acid Settler
Ammonia
Asphalt Settler
Benzene
Blow Case
Boilers
Brine
Butane
Caustics
Collection Pots
De-Ionized Water
Diesel

Dow Therm
Drip Pot
Environmental
Extreme Flashing Liquids
Feedwater Heaters
Flare Drums
Freon
Glycol
Hydraulic Oil
Hydrazine
Hydrochloric Acid
Hydrofluoric Acid
Hydrogen Sulphide

ISO Butane
Interface (Oil/Water)
Interface (Oil/Caustic)
Interface (Oil/Acid)
Jet Fuel
LPG
Liquid Carbon Dioxide
Liquid Ethylene
Methyl Chloride
Molten Sulfur
Muriatic Acid
Phosgene
Propane

Seal Oil Pot
Slop Oil
Solvents
Sour Oil
Sour Water
Steam Drums
Sulfuric Acid
Sumps
Therminol
Volume Chambers
Water
Xylene
Zymurgy Vats

SPECIFIC APPLICATIONS

POWER PLANTS

Water, Boilers, Condensate Pots, Day Tanks (Acid, Caustic SO₂, Ammonia), Steam Drums, Feedwater Tanks, Heater Drums, Dearthors

UTILITIES

Condensate, Water, Boilers, Feedwater Tanks

PETROCHEM

Acids - (Sulfuric, Hydrochloric, Hydrofluoric, Acetic, Phosphoric etc..), Steam Condensate, Circulating Fluids, (Dowtherm, Glycol etc..), Solvents, Caustics, LPG Fuels, De-Ionized Water, Ammonia, Freon, Heptane, Methyl Chloride, Sodium Hypochlorite, Caustic Soda

PULP & PAPER

Chlorine, Slurry Tanks, Steam Condensate, Boilers, Receivers, Pots, Acids, Hydrogen Peroxide

Flare Knock-Out Vessels

Hydrocarbon Mix

COMPRESSORS & PUMPS

Oil Sumps, Oil Seal Reservoirs

TANK FARMS

Propane, Butane, Oil, Gasoline

PROCESS VESSELS

Reactors, Absorbers, Scrubbers, Decanters

VACUUM TOWERS

Crude, Gasoline, Light Hydrocarbons

PHARMACEUTICAL

Acids, Caustics, Solvents, De-Ionized Water

CHILLERS

Ammonia, Freon

LIQUID GAS PLANTS

Propane, Butane

REFINERY'S

Benzene, Toluene, Gasoline Kerosene, Ethylene, Butane, Propane, Iso-Butane, Heavy and Light Oils, Solvents

SULFUR PLANT

Molten Sulfur

ASPHALT PLANT

Hot Asphalt, Pitch

ALKYL PLANT

Acids (Sulfuric, Hydrochloric, Hydrofluoric)

COKER PLANT

Sour Water, Naptha, Glycol, Light and Heavy Oils

D & C Plant

Acids, Sour Water

ISOMAX

Acids, Sour Water, Chlorine

See Application bulletin 2000 for more Details

PRO MAG LTD

HOW DOES THE PM-26 WORK?

A specially designed and engineered float is housed in a non-magnetic chamber. The float is weighted to the specific gravity of the process fluid and is equipped with a series of magnets which generates a sufficient flux so as to attract another magnetic assembly on the outside of the chamber.

This external magnetic assembly is a fluorescent orange indicator which is hermetically sealed in a special glass or polycarbonate tube attached to the external wall of the float chamber.

As the float moves with the changes in the liquid level of the vessel, the strong magnetic attraction between the indicator and float will ensure that the indicator will track the position of the float exactly and thus, in turn, the liquid level precisely.

The magnetic strength of the float-indicator assembly makes the **PM-26** the preferred level gauge for severe vibration applications.

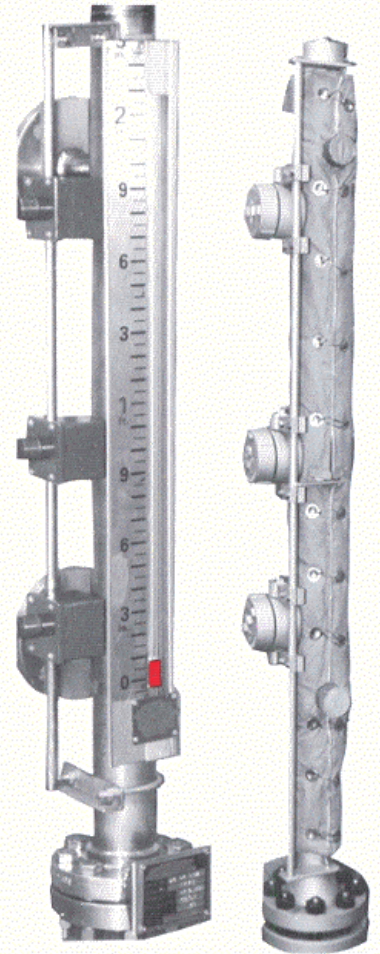
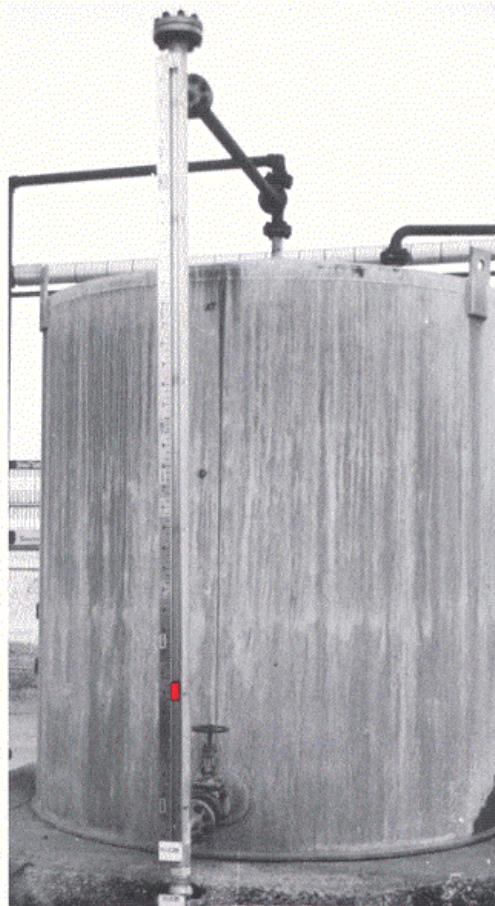
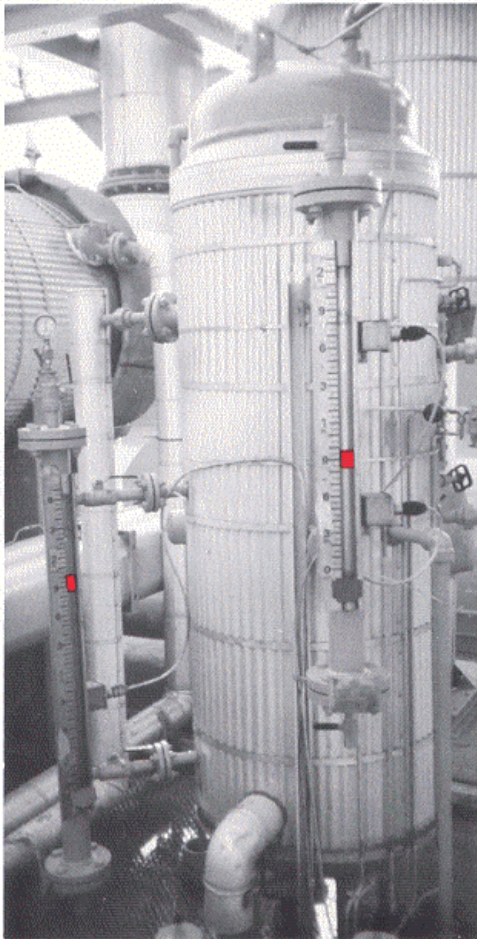
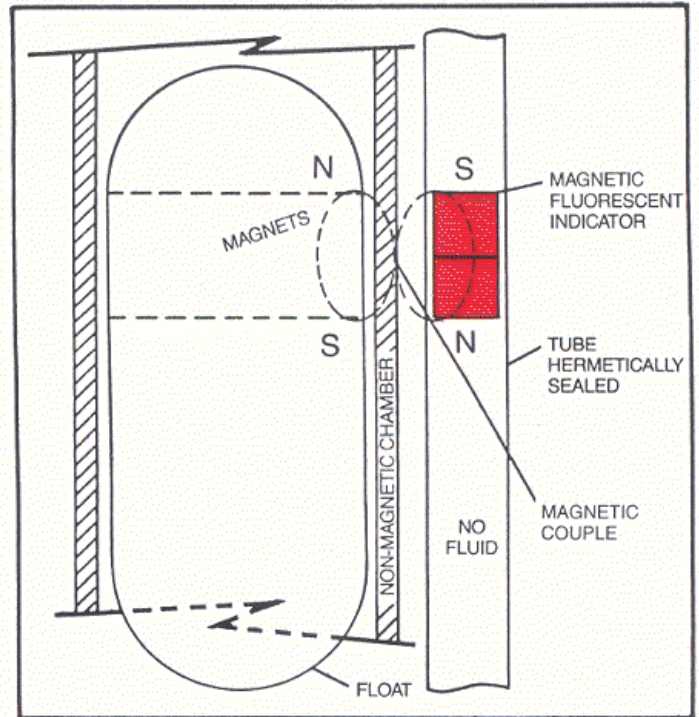

TYPICAL INSTALLATIONS

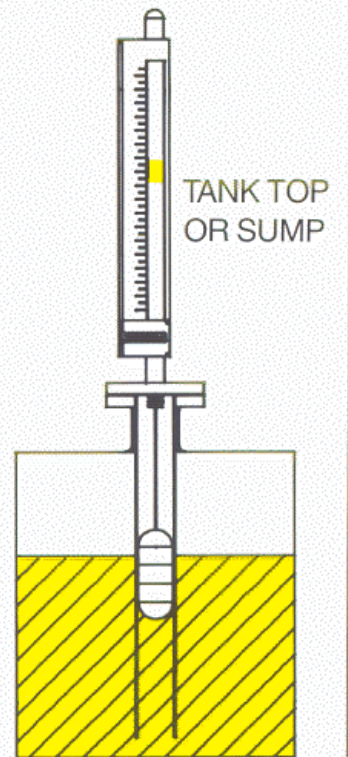
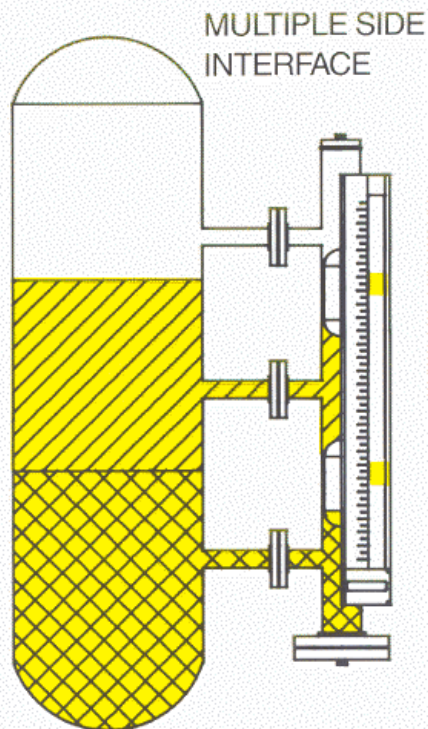
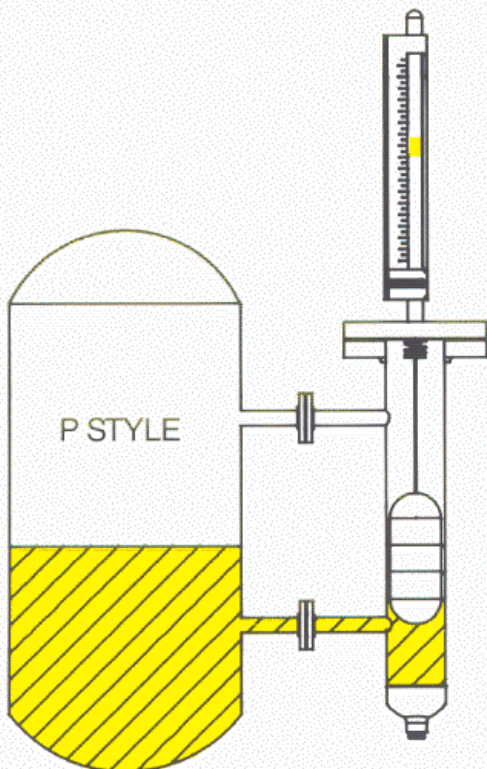
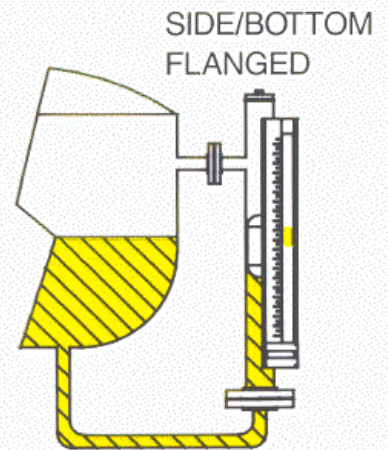
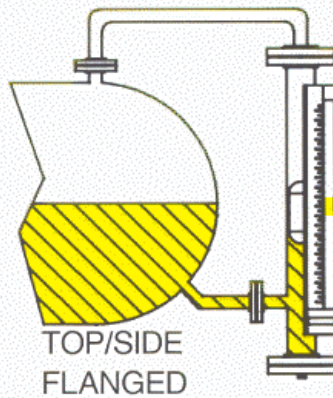
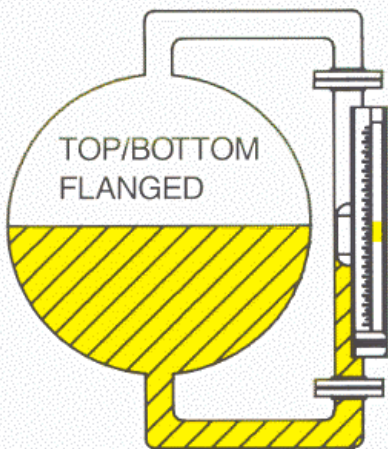
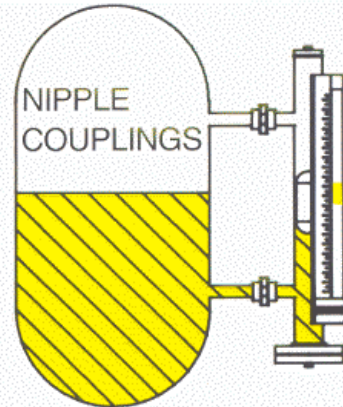
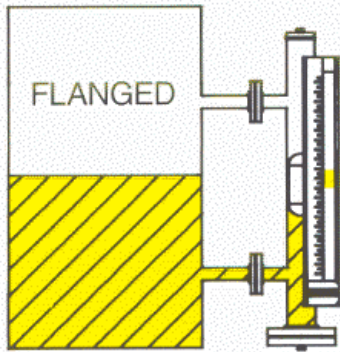

OPTIONAL EQUIPMENT - SWITCHES

REED SWITCH

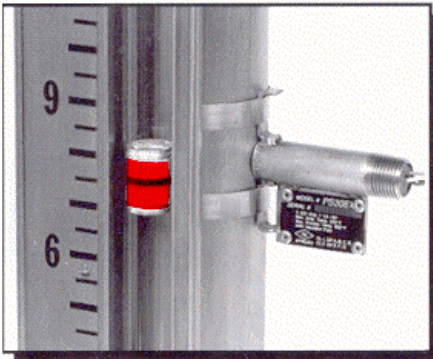

ES30EX Switch
(Clamp Mounted)

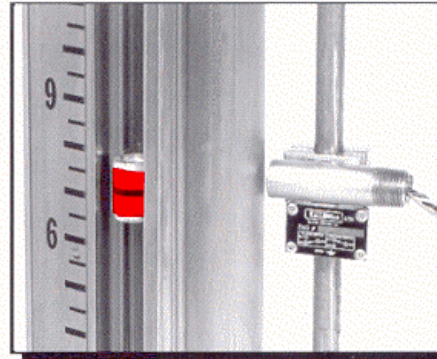

ES30EX SWITCH
(Rod Mounted)

See [Bulletin 1002](#) for more Details



MERCURY SWITCH



ES21 NEMA 4x
(Clamp Mounted)



ES21 NEMA 4x
(Rod Mounted)

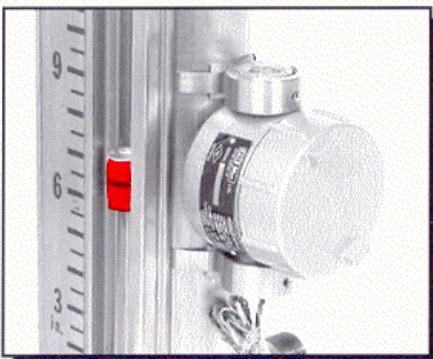

ES21EX
(Clamp Mounted)



ES21EX
(Rod Mounted)

See [Bulletin 1003](#) for more Details



OPTIONAL EQUIPMENT - SWITCHES

MICRO-SWITCH

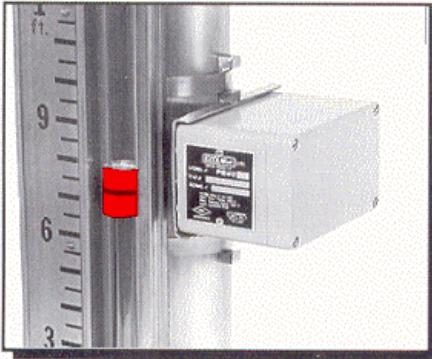

ES40 Switch
(Clamp Mounted)
NEMA 4X
Fiberglass Housing

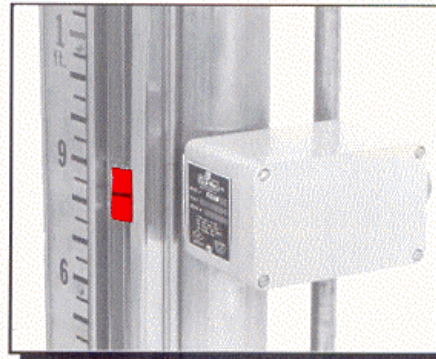

ES40 SWITCH
(Rod Mounted)
NEMA 4X
Fiberglass Housing

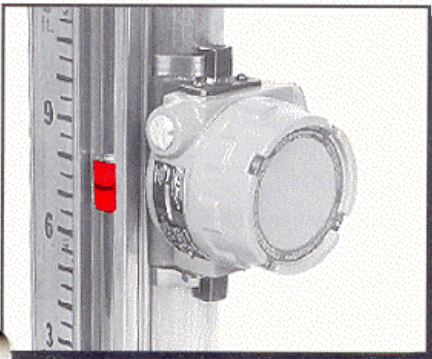

ES40EX
(Clamp Mounted)
NEMA 7

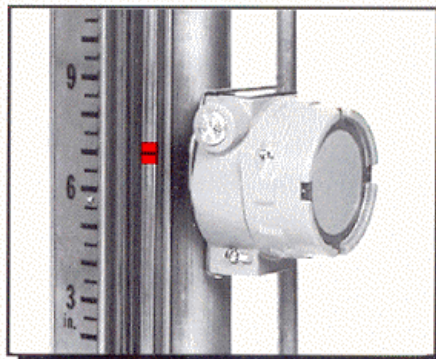

ES40EX
(Rod Mounted)
NEMA 7

See [Bulletin 1004](#) for more Details



PNEUMATIC SWITCH

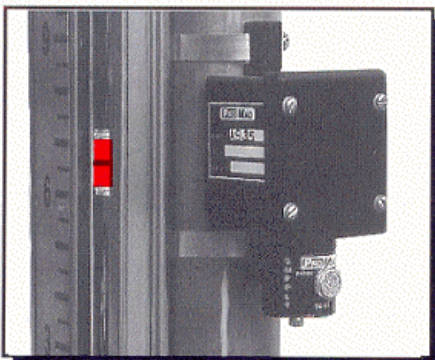

AS35

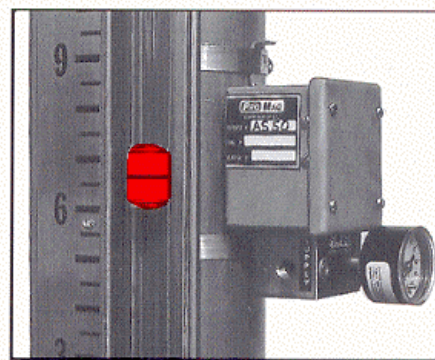

AS50

All Stainless Steel
Construction
Input / Output
Gauge Ports

See [Bulletin 1005](#) for more Details

OPTIONAL EQUIPMENT CLT's / CONTROLLERS

CONTINUOUS LEVEL TRANSMITTERS

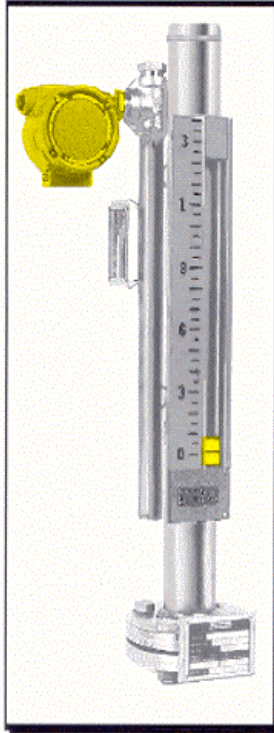

**CLT-C25
EXTERNAL**

Mounted on
PM-26

High
Temperature
Applicable

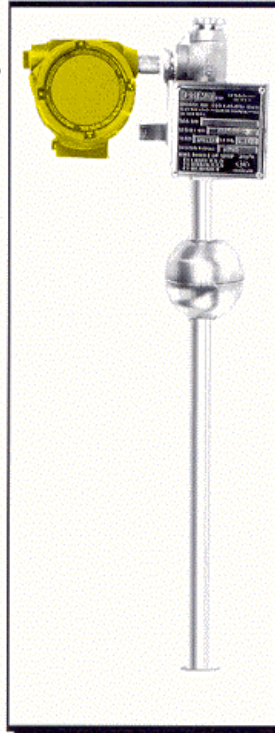

**CLT-I25
INTERNAL**

Guide Tube

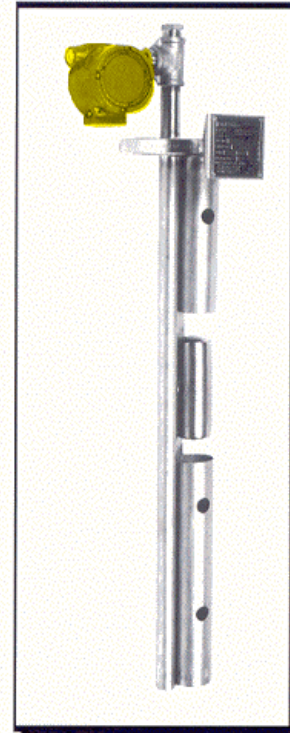

**CLT-S25
INTERNAL**

Stilling Well

See **Bulletin 1008** for more Details



ELECTRO-PNEUMATIC CONTROLLERS

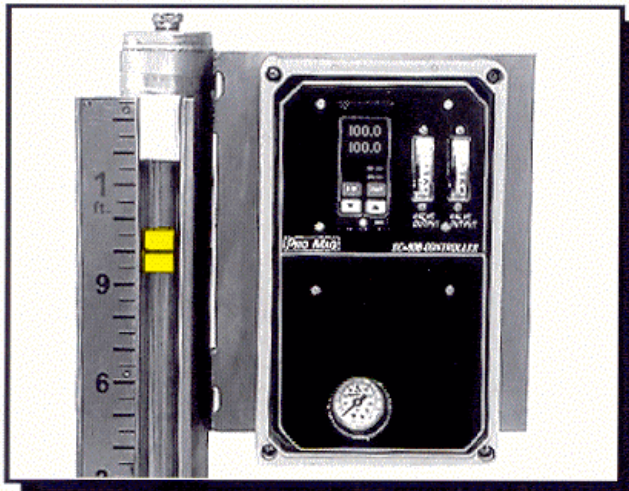

EC-808

See **Bulletin 1009** for more Details



EC-811

See **Bulletin 1010** for more Details

OPTIONAL EQUIPMENT - INDICATORS

EXPLOSION-PROOF DIGITAL INDICATORS



PDI-1100
LCD Display

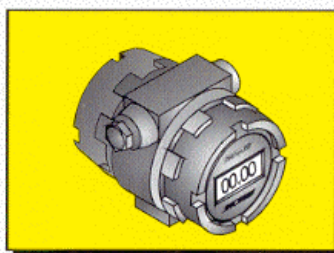

PDI-1100T
LCD Display
Transmitter

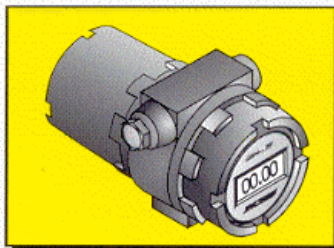

PDI-1100PS
LCD Display
Power Supply

See **Bulletin 1008** for more Details

NEMA 4 DIGITAL INDICATORS

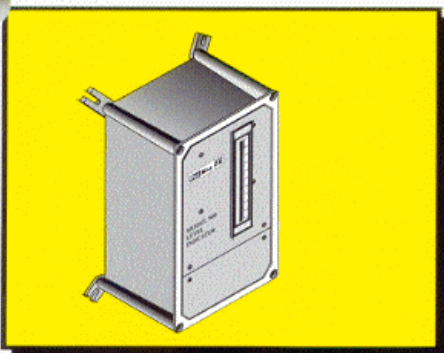

MODEL 900
Bargraph Display

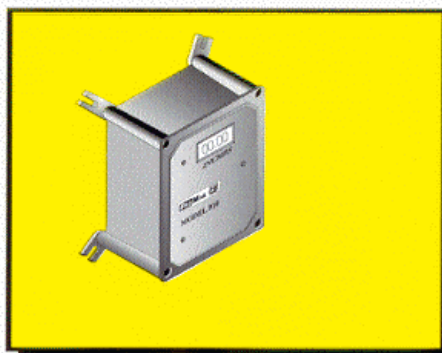

MODEL 910
LCD Display

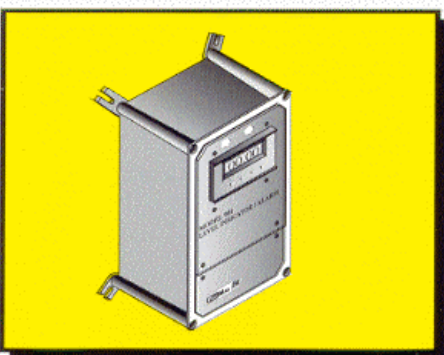

**MODELS
901, 902
903, 904**
Fluorescent Display

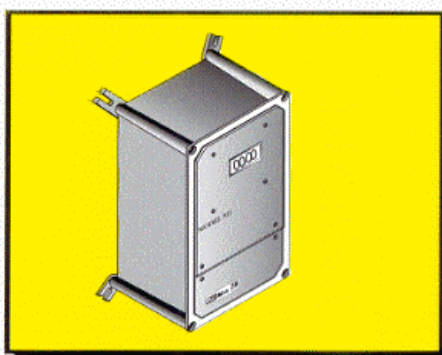

MODEL 911
LCD Display

See **Bulletin 1008** for more Details

OPTIONAL EQUIPMENT

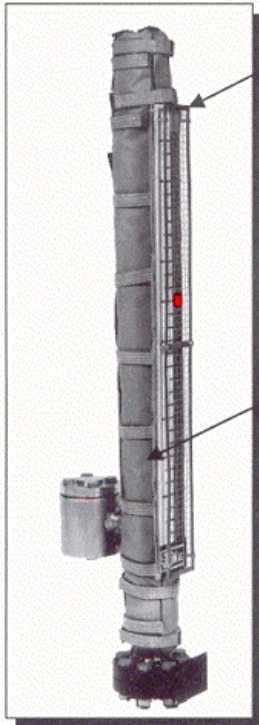

1 FRONT SCALE PROTECTION

- * Prevents damage to Scale and Indicator.
- * Consult Factory for Information on other Insulation and Scale damage protection devices available.

2 PM-26 INSULATION BLANKET

- * Freeze Protection
- * Personnel Protection
- * PM-26 Control of Heat Loss / Gain
- * Steam Tracing
- * Electric Heat Tracing / Thermostats / Temperature Controllers

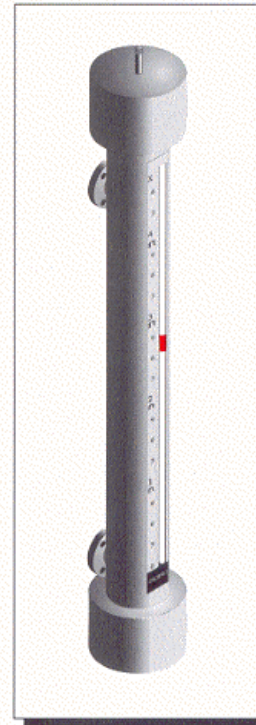

CRYOGENIC INSULATION

- * Frost Protection
- * Reduced Flashing
- * - 375 ° F

CLT INSULATION PAD

High Temperature

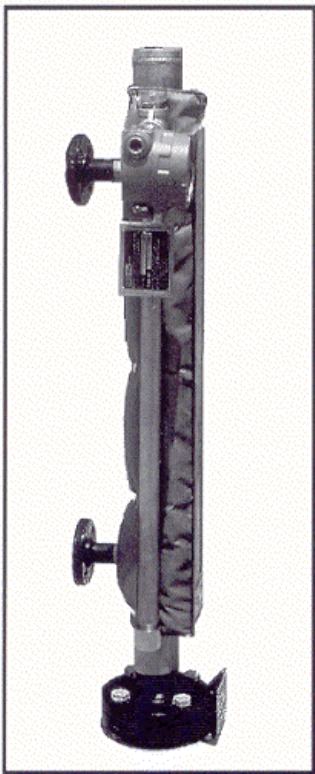

SWITCH INSULATION PAD

High Temperature

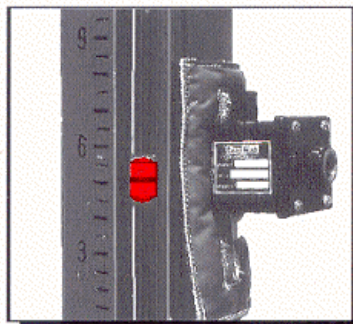
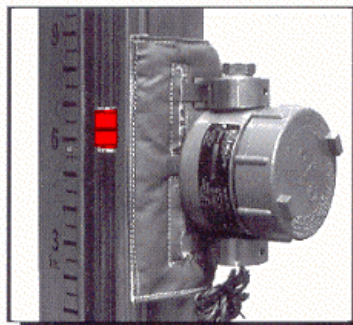

MAGNETIC TRAP

Ferrous Particle Removal

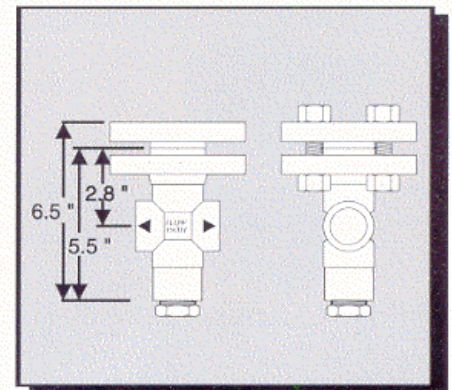

REQUEST FOR QUOTE / ORDERING INFORMATION

Rep Name _____

Salesman _____

Customer _____

Customer Contact _____

1 APPLICATION DATA

Process Fluid _____
% Concentration _____
Specific Gravity (at Operating Temp) _____
Interface Specific Gravity _____ / _____
Pressure Design / Operating _____ / _____
Temp Design / Operating _____ / _____

2 FABRICATION DATA

Chamber Material _____
Process Connection Material _____
Vent / Drain Connection _____
Material
Process Connection
Size Rating
Flange _____ / _____
Coupling _____ / _____
Nipple _____ / _____
Gussets Yes Support Bracket Yes
Vent / Drain Valves
(Ball, Gate, Plug, and Mfg) _____

3 INDICATION DATA

Inches of Visual Indication _____
Inches of Center to Center _____
Indicator : Standard Flashing

Special Scale (Describe : Provide Drawing)

Glass Tube Protector: Yes

4 INSULATION

Blanket Cryogenic
Indicator Non-Frosting
Protection :
Steam Electric

5 HEAT TRACING

Steam Electric
Reason for Heat Tracing:
Freeze Protection
Maintaining Process Temperature

6 SWITCHES

Electrical _____ Part # _____
ES-21 _____
ES-30EX _____
ES-40 _____
Hazardous Classification _____

Pneumatic _____ Block / Bleed _____
AS-35 Rising Level
AS-50 Falling Level
Supply Gas _____

Clamp Mount Rod Mount Pad Mount
(above 200 deg F)

7 OTHER OPTIONS

CLT (Remote Transmitter) _____
Controllers _____
Indicators _____

Provide Sketch

Questions and / or Notations

- (1) Are there any obstructions that will limit our dimensions on this PM-26 ?
- (2) Orientation of Scale Kit ?
- (3) Orientation of Process Connections ?
- (4) Will you have enough clearance to remove the float from the bottom of the PM-26 Chamber ? Note: Lower Specific Gravities may require a longer dead leg.

Part # **PM26-** _____

Refer to pages 12, 13, 14, and 15 to determine correct part number.

MAGNETIC INDICATOR SELECTION GUIDE

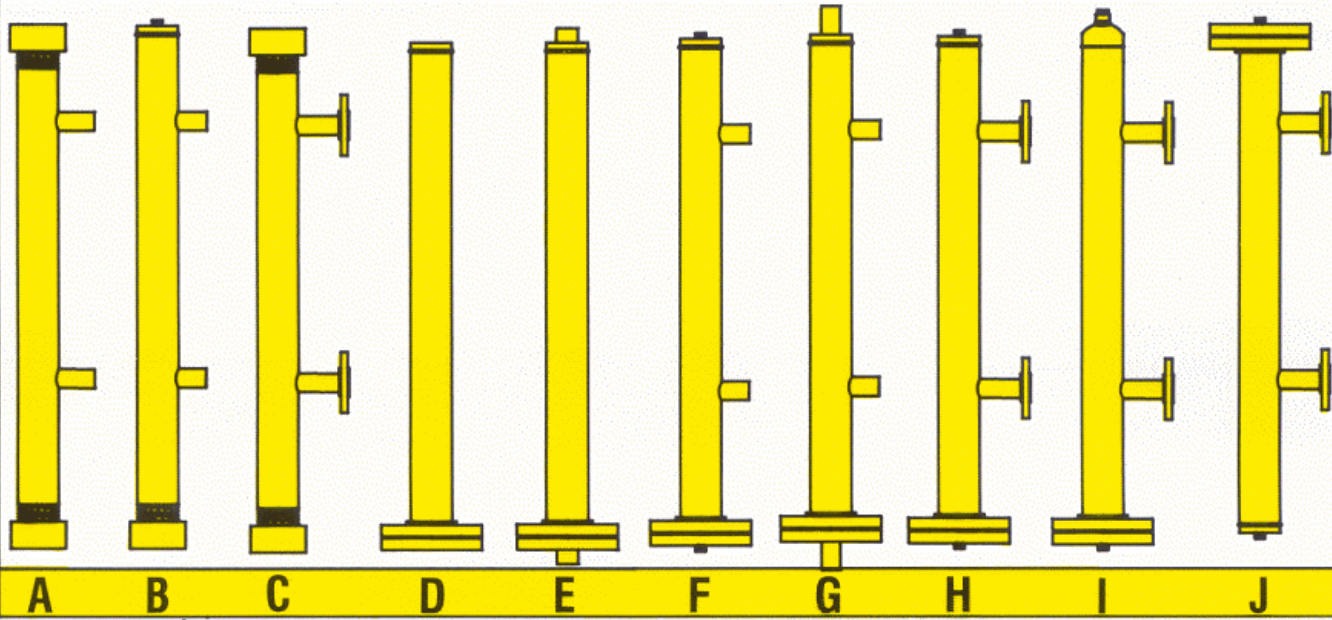

NOTE: If a configuration that you prefer does not appear above choose the one that is closest to your needs and add a V after the letter of the configuration chosen.
 EXAMPLE: You select H but only want one side connection. The part is therefore HV.

PM 26 - H / (X) / 4S - CS / ABCD / FWR1A / P5-P5 / XX /

CHAMBER SIZE

CHAMBER

CONNECTIONS

SEE FIG. 1 BELOW

SEE PAGE 14 AND 15 CONNECTIONS OPTIONS
 NOTE: IF ONE OF THE CODES (ABCD) DOES NOT REQUIRE A SELECTION REPLACE THAT CODE WITH AN X.

MATERIAL SPECIFICATIONS

CONNECTION STYLE / SIZE / RATING			
TYPE			
C	THREADED COUPLING	N	NIPPLE
SC	SOCKET ELD COUPLING	U	UNION
SO	SOCK-O-LET		
T	THREAD-O-LET		
WO	WELD-O-LET		
F	FLANGE		
FB	FULL BORE FLANGE (USED FOR 1 1/2" AND LARGER FLANGES WHEN 1" BORE IS NOT DESIRED)		
FLANGE STYLE			
SF	FIXED SLIP-ON FLAT FACE	WT	WELDNECK TONGUE & GROOVE
SJ	FIXED SLIP-ON RING-JOINT	LS	LOOSE FLANGE & STUB END
SM	FIXED SLIP-ON MALE/FEMALE	BR	BLIND RAISED
SR	FIXED SLIP-ON RAISED FACE	BF	BLIND FLAT
ST	FIXED SLIP-ON TONGUE & GROOVE	SW	SOCKET WELD
WF	WELDNECK FLAT FACE	TR	FIXED THREADED RAISED FACE
WJ	WELDNECK RING-JOINT		
WM	WELDNECK MALE/FEMALE		
WR	WELDNECK RAISED FACE		
SIZE			
5	1/2"		
7	3/4"		
1	1"		
15	1 1/2"		
2	2"		
25	2 1/2"		
3	3"		
4	4"		
6	6"		
8	8"		
10	10"		
CLASS			
A	150 LBS.	J	SCHEDULE 40
B	300 LBS.	K	SCHEDULE XX
C	600 LBS.	L	6000 LBS.
D	1500 LBS.	M	9000 LBS.
E	2500 LBS.		
F	3000 LBS.		
G	SCHEDULE 80		
H	SCHEDULE 160		

CODES	DESCRIPTIONS	CODES	DESCRIPTIONS
4S	304SS	4TC*	TEFLON COATED 304SS
4LS	304LSS	6TC*	TEFLON COATED 316SS
6S	316SS		**SLIP RESISTANCE ONLY
6LS	316LSS	4TL	TEFLON LINED 304SS
1S	321SS	6TL	TEFLON LINED 316SS
HC	HASTELLOY C276	4H	HALAR COATED 304SS
HB	HASTELLOY B2	4LH	HALAR COATED 304LSS
M	MONEL	6H	HALAR COATED 316SS
A20	ALLOY 20	6LH	HALAR COATED 316LSS
*CS	CARBON STEEL		
*CHAMBER ONLY AVAILABLE IN P&Q Styles			
K	KYNAR	ELECTROLESS NICKEL PLATING	
F	FIBERGLASS	4N	PLATED INSIDE ONLY
PVC	PVC	6N	PLATED INSIDE ONLY
CPV	CPVC	4NO	PLATED INSIDE AND OUTSIDE
		6NO	PLATED INSIDE AND OUTSIDE

EXAMPLE F WR 1 A

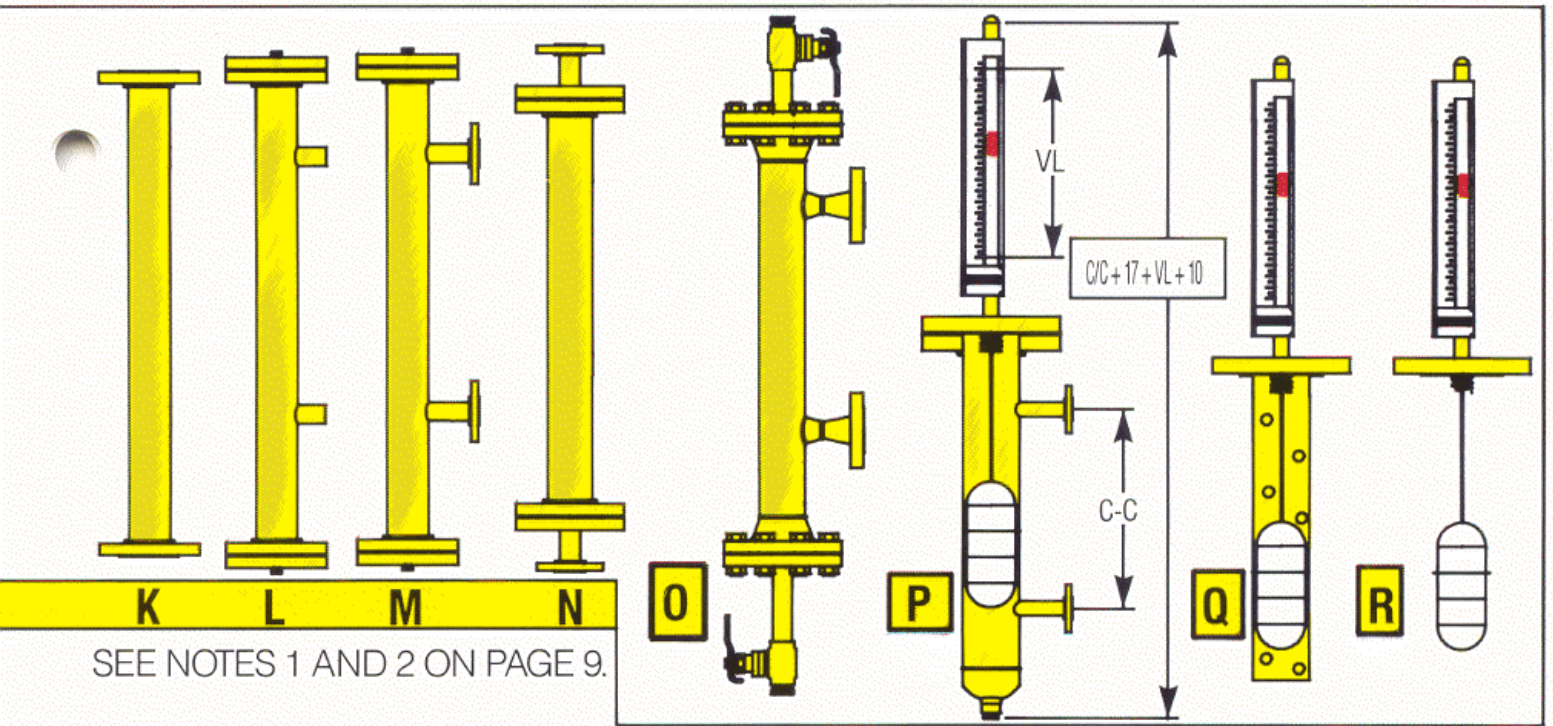

SEE NOTES 1 AND 2 ON PAGE 9.

INCHES OF VISUAL INDICATION / CENTER - CENTER

VENT / DRAIN	
PLUG OPTIONS	THREAD OPTIONS
P5 1/2"	F5 1/2"
P7 3/4"	F7 3/4"
P1 1"	F1 1"
VALVE OPTIONS	SOCKET OPTIONS
V5 1/2"	S5 1/2"
V7 3/4"	S7 3/4"
V1 1"	S1 1"

SPECIFY THE REQUIRED VALVE OPTIONS:
BALL GATE OR PLUG:
MANUFACTURE:

OTHER OPTIONS	
B	INSULATION BLANKET
C	CRYOGENIC INSULATION
CF	COATED FLOAT
ET	ELECTRIC TRACING
ETC	ELECTRIC TRACING WITH CONTROLLER
G	PROCESS CONNECTION GUSSETS
I	INDICATOR NON-FROSTING PROTECTION
GTP	GLASS TUBE PROTECTOR
A	ACRYLIC RULER
AH	ACRYLIC RULER HIGH TEMP (ABOVE 140°)
P	POLYCARBONATE TUBE
R	SWITCH ROD FOR HIGH TEMPERATURE
S	SPECIAL SCALE (STAINLESS STEEL)
SB	SUPPORT BRACKET
SO	STAND-OFF
ST	STEAM TRACING
XX	NO OPTIONS
FI	FLASHING INDICATOR
CP	CLT PAD
SP	SWITCH PAD

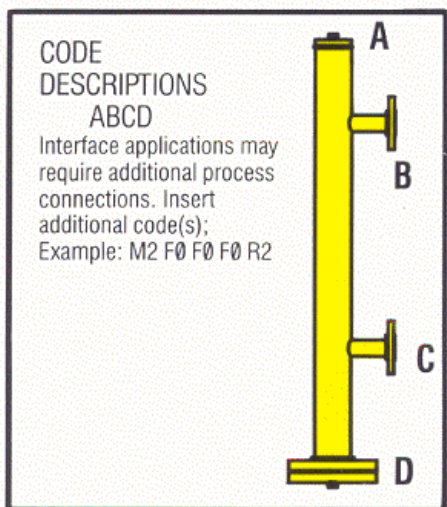

FIGURE 1

D I M E N S I O N S

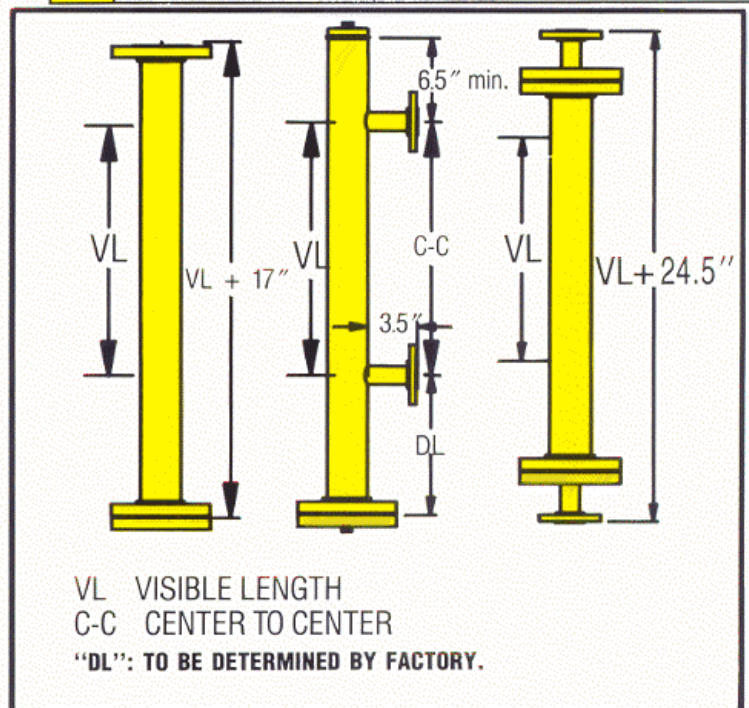
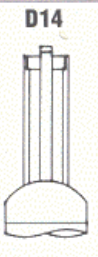
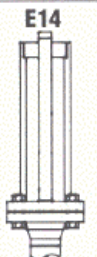

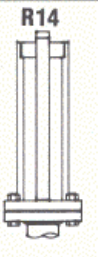













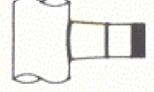
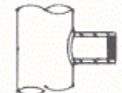

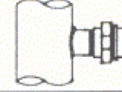
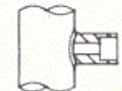

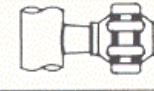
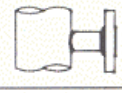
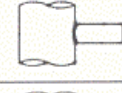
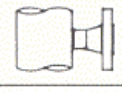
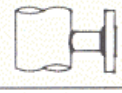
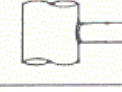
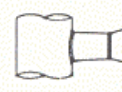
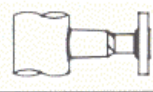
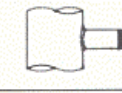
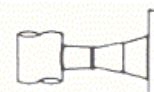
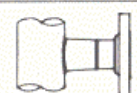

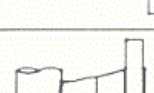
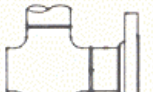
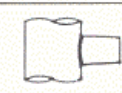

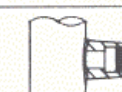

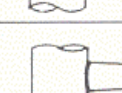
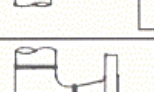

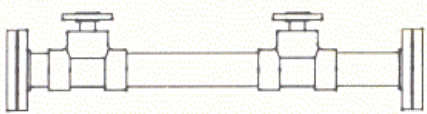
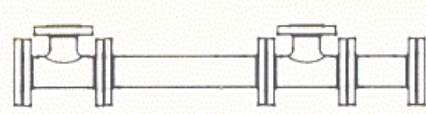

FIGURE 2

TOP AND BOTTOM OPTIONS

	F0: Fixed flange (slip on) F2: Fixed flange (socket)		W0: Weldneck flange		M0: Welded flat pipe cap/Spring
	R0: Fixed Flange/Blind Flange/Spring.		E0: Weldneck flange/Blind flange/Spring.		M1: Welded flat pipe cap/FNPT/Spring.
	R1: Fixed Flange/Blind Flange with FNPT/Spring.		E1: Weldneck flange/Blind flange with FNPT/Spring.		M2: Welded flat pipe cap/Plug/Spring
	R2: Fixed Flange/Blind Flange with plug/Spring		E2: Weldneck Flange/Blind flange with plug/Spring		M3: Welded flat pipe cap/Socket weld bore/Spring
	R3: Fixed Flange/Blind Flange with socket weld coupling/Spring		E3: Weldneck flange/Blind flange with socket weld coupling/Spring		M4: Welded flat pipe cap/FNPT coupling/Spring
	R4: Fixed Flange/Blind Flange with threaded coupling/Spring		E4: Weldneck flange/Blind flange with threaded coupling/Spring		M5: Welded flat pipe cap/Nipple for socket welding (flat)/Spring
	R5: Fixed Flange/Blind Flange with socket weld nipple (flat edge)/Spring		E5: Weldneck flange/Blind flange with socket weld nipple (flat)/Spring		M6: Welded flat pipe cap/Nipple for butt welding (37.5° bevel)/Spring
	R6: Fixed Flange/Blind Flange with butt weld nipple (37.5° bevel)/Spring		E6: Weldneck flange/Blind flange with butt weld nipple (37.5° bevel)/Spring		M7: Welded flat pipe cap/MNPT nipple/Spring
	R7: Fixed Flange/Blind Flange with threaded nipple/Spring		E7: Weldneck flange/Blind flange with threaded nipple/Spring		M8: Welded flat pipe cap/Nipple-Flange/Spring
	R8: Fixed Flange/Blind Flange with reducing flange/Spring		E8: Weldneck flange/Blind flange with reducing flange/Spring		M9: Welded flat pipe cap/spring/plug or ball valve
	R9: Fixed Flange/Blind Flange with bored for socket welding/Spring		E9: Weldneck flange/Blind flange bored for socket welding/Spring		M10: Welded Flat Cap/MNPT Nipple/Threaded Union
	R10: Fixed Flange/Blind Flange with spring/plug or ball valve		E10: Weldneck Flange/Blind Flange with spring/plug or ball valve		M12: Welded flat pipe cap/spring/gate valve
	R11: Fixed Flange/Blind Flange with spring/2 plug or ball valves		E11: Weldneck Flange/Blind Flange with spring/2 plug or ball valve		T0: Threaded pipe cap (3000#)/Spring. Sch 40 min.
	R12: Fixed Flange/Blind Flange with gate valve/Spring		E12: Weldneck Flange/Blind Flange with spring/2 plug or ball valve		T1: Threaded pipe cap (3000#)/Spring. Sch 40 min.
	R13: Fixed Flange/Blind Flange with 2 gate valves/Spring		E12: Weldneck flange/Blind flange with gate valve/Spring		T2: Threaded pipe cap/Plug/Spring. Sch 40 min.
	H. Hex plug		E13: Weldneck flange/Blind flange with 2 gate valves/Spring		C2: FNPT Coupling/Hex Plug (for vent and drain applications)
					CR1: Concentric Reducer/Flange/Spring

SIDE OPTIONS

					D0: Butt weld dome pipe cap/Spring		D5: Butt weld dome pipe cap/Nipple for butt welding (37.5° bevel)/Spring		
					D1: Butt weld dome pipe cap/FNPT coupling/Plug/Spring		D6: Butt weld dome pipe cap/MNPT nipple/Spring		
Top Assembly = TA					D2: Butt weld dome pipe cap/Socket weld coupling/Spring		D7: Butt weld dome pipe cap/Nipple/Flange/Spring		
D14P	Side Mount/BW Dome Cap/TA				D3: Butt weld dome pipe cap/FNPT coupling/Spring		D8: Butt Weld Dome Pipe Cap/Spring/Ball Valve		
E14P	Side Mount/Weldneck/Blind/TA				D4: Butt weld dome pipe cap/Nipple for socket welding (flat)/Spring		D9: Butt Weld Dome Pipe Cap/Spring/Gate Valve		
P14P	Side Mount/Hex Plug/TA								
R14P	Side Mount/Slip-On/Blind/TA								
P14Q	Hex Plug/Stirling Well/TA								
R14Q	Blind/Stirling Well/TA								
P14R	Hex Plug and TA only								
R14R	Blind and TA only								
R15	Reducing Filler Flange								
R16	R14 w/o Top Assembly								
	B0: Connection with reducing spool piece for coated units.				LF1: Lap joint flange/stub end/tee		N8: Weld-o-let with threaded nipple		
	C0: FNPT coupling				LF2: Lap joint flange/stub end/tee concentric reducer/tee		N9: MNPT nipple with threaded union		
	C1: Socket weld coupling				LF3: Lap joint flange/stub end (Used on vent & drain)		N10: Graylock® Connector/Weld-O-let		
	F0: Fixed flange (slip on)				N0: Branch nipple for socket welding (flat)		W0: Weldneck flange		
	F2: Fixed flange (socket)				N1: Branch nipple for butt welding (37.5° bevel)		W1: Weldneck flange/weld-o-let		
	F1: Fixed flange/sock-o-let				N2: MNPT branch nipple		W2: Weldneck flange/weld-o-let/concentric reducer		
	F3: Fixed Flange/Weld-O-Let				N3: Sock-o-let		W3: Weldneck flange/concentric reducer		
	F4: Fixed Flange/Butt Weld Pipe Cross				N4: Weld-o-let		W4: Weldneck flange/concentric reducer/tee		
	F5: Fixed Flange/Butt Weld Pipe Tee				N5: Thread-o-let		W5: Weldneck Flange/Butt Weld Pipe Tee		
	G: Graylock® Connectors				N6: Weld-o-let with socket weld nipple (flat)		W6: Weldneck Flange/Elbow/Weld-O-Let		
	LF0: Lap joint flange (loose) with stub end				N7: Weld-o-let with butt weld nipple (37.5° bevel)				
				S: Configuration for PVC, CPVC, Kynar Units					
								T: Configuration for Teflon Lined Units	

Applications only limited by your Imagination !

On site Time/ Rate measurement
Units, Skid Packages.

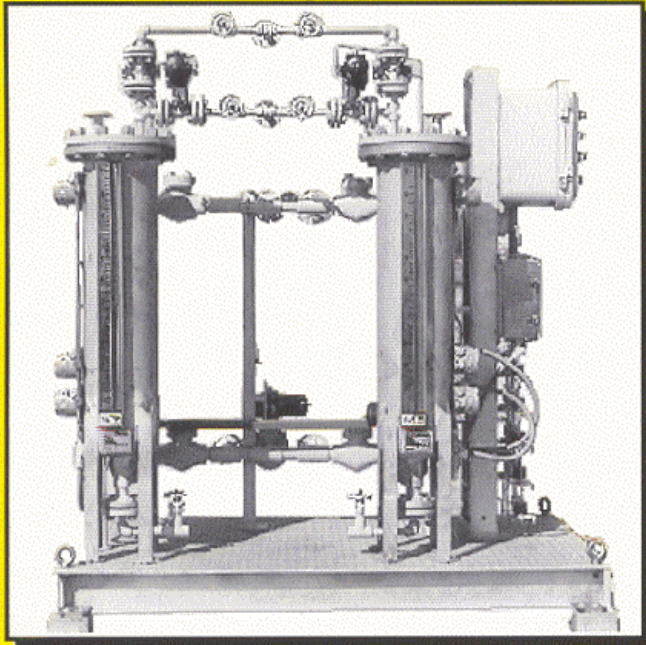

Unmanned Sub Ballast Tank.



Seal Oil Chambers



Pressure Powered Separators



Home Office and Manufacturing
P.O. Box 84158 11552 Merchant Dr.
Baton Rouge, LA Baton Rouge, LA
70884-4158 70809

Represented by

PRO MAG LTD

16 Phone: (225) 751-7755 Fax: (225) 751-7750

Revised 1/99